

SM Split CS Series Heat Pump

SM024 | SM036 | SM048 | SM060



BOSCH

Installation, Operation, and Maintenance Manual

8733827905 (2021/11)

CONTENTS

Document Conventions	3	UPM LED Status Indicator (Blink Code) Information	31
Key to Symbols.....	3	Compressor Ohms	31
Safety Warnings.....	3	Operating Temperatures and Pressures.....	32
Model Nomenclature	4	Maintenance	36
CS/Air Handler Pairing	5	Water Side Pressure Drop in PSIG	36
SM Split CS Standard Package	6	Decommissioning Information	37
General Description	6	Protecting the Environment	37
Moving and Storage	6	Wiring Diagrams	38
Initial Inspection	6	Dimensional Drawings.....	40
Unit Installation	7	Terminology	41
Location Selection.....	7	Acronyms	41
Condensing Section Location	7	Terms.....	41
Air Handler Location.....	7	Notes	42
Installation	7		
Condensing Section Installation	7		
Condensate Drain	8		
Water Piping	8		
Refrigerant Lines	9		
Linear vs. Equivalent Line Length	9		
Connecting Refrigerant Lines.....	9		
Additional Adjustments Required when Pairing SM Split CS with BVA2.0 and BMAC	11		
Water Quality Table.....	14		
Electrical	15		
Safety Devices and the UPM Controller	16		
Typical System Setup	19		
Specific Application Considerations	20		
Well Water Systems	20		
Cooling Tower/Boiler Systems	20		
Geothermal Systems	20		
Post-Installation System Checkout	21		
System Operation	21		
Unit Start-up	21		
Sequence of Operation	21		
Standard Factory-Installed Components	23		
Pump/Valve Relay	23		
Field-Installed Accessories	23		
Flow Proving Switch (DPS)	23		
SmartStart Assist Specifications	24		
SmartStart Assist Modes of Operations	24		
Check-Out Sheet	27		
Troubleshooting.....	28		
SmartStart Assist Troubleshooting	30		
SmartStart Assist Flashing Sequence.....	30		

DOCUMENT CONVENTIONS

Key to Symbols

Warnings



Warnings in this document are identified by a warning triangle printed against a gray background. Keywords at the start of the warning indicate the type and seriousness of the ensuing risk if measures to prevent the risk are not taken.

The following keywords are defined and can be used in this document:

- **DANGER** indicates a situation that, if not avoided, will result in death or serious injury.
- **WARNING** indicates a situation that, if not avoided, could result in death or serious injury.
- **CAUTION** indicates a situation that, if not avoided, could result in minor to moderate injury.
- **NOTICE** is used to address practices not related to personal injury.

Important Information



This symbol indicates important information where there is no risk to property or people.

SAFETY WARNINGS



IMPORTANT: Read the entire instruction manual before starting installation or service.



DANGER: PERSONAL INJURY HAZARD
Installation and servicing of this equipment can be hazardous due to system pressure and electrical components. Only trained and qualified personnel should install, repair, or service the equipment.



DANGER: ELECTRIC SHOCK
Before performing service or maintenance operations on the system, turn off main power to the unit. Electrical shock will cause personal injury or death.



DANGER: FLAMMABLE REFRIGERANT
R410A is flammable when exposed to open flame. Recover all refrigerant prior to brazing.



WARNING: When working on equipment, always observe precautions described in the literature, tags, and labels attached to the unit. Follow all safety codes. Wear safety glasses and work gloves. Use a quenching cloth for brazing, and place a fire extinguisher close to the work area.



WARNING: This product can expose you to chemicals including Lead and Lead components, which are known to the State of California to cause cancer and birth defects or other reproductive harm.

For more information go to www.P65Warnings.ca.gov.



CAUTION: PERSONAL INJURY HAZARD

Sheet metal parts may have sharp edges or burrs. Use care and wear appropriate protective clothing and gloves when handling parts.

NOTICE: To avoid the release of refrigerant into the atmosphere, the refrigerant circuit of this unit must be serviced only by technicians who meet local, state, and federal proficiency requirements.

NOTICE: All refrigerant discharged from this unit must be recovered WITHOUT EXCEPTION. Technicians must follow industry accepted guidelines and all local, state, and federal statutes for the recovery and disposal of refrigerants. If a compressor is removed from this unit, refrigerant circuit oil will remain in the compressor. To avoid leakage of compressor oil, refrigerant lines of the compressor must be sealed after it is removed.

NOTICE: To avoid equipment damage, DO NOT use these units as a source of heating or cooling during the construction process. Doing so may affect the unit's warranty. The mechanical components and filters will quickly become clogged with construction dirt and debris, which may cause system damage or failure.

MODEL NOMENCLATURE

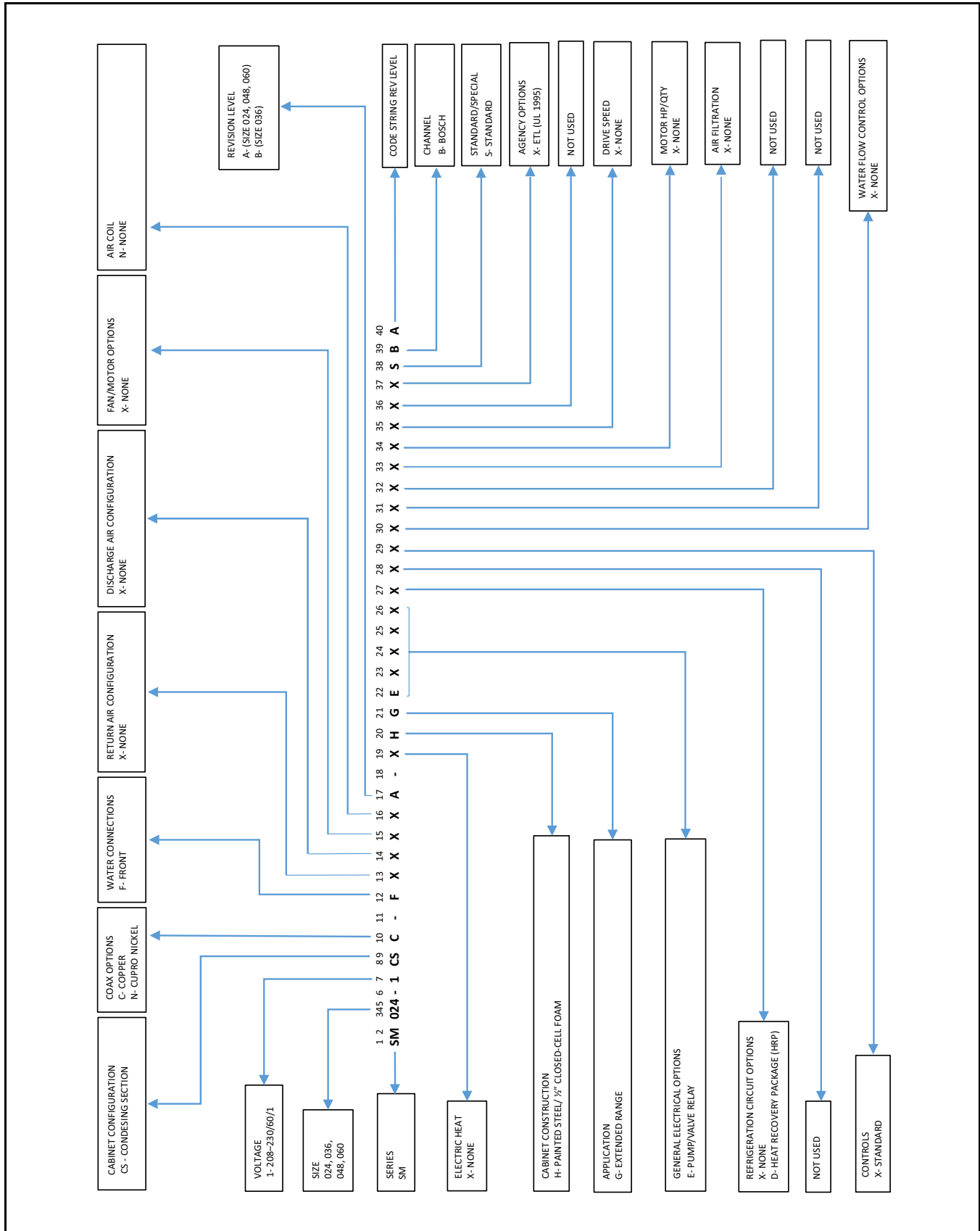

Fig. 1 Model Nomenclature

CS/AIR HANDLER PAIRING

UNIT MODEL	Paired Air Handler			
	Pairing 1	Pairing 2	Pairing 3	Pairing 4
SM024-1CS	SM024-1AVX	SM024-1AHX	BMAC2430BNTD	BVA-24WN1-M20
SM036-1CS	SM036-1AVX	SM036-1AHX	BMAC3036BNTD	BVA-36WN1-M20
SM048-1CS	SM048-1AVX	SM048-1AHX	BMAC4248CNTF	BVA-48WN1-M20
SM060-1CS	SM060-1AVX	SM060-1AHX	BMAC4860CNTF	BVA-60WN1-M20
LEGEND:				
AV	BOSCH Box Style Vertical Air Handler			
AH	BOSCH Box Style Horizontal Air Handler			
BMAC	BOSCH Cased/Uncased Coil			
BVA2.0	BOSCH Unitary Style Air Handler			

SM SPLIT CS STANDARD PACKAGE

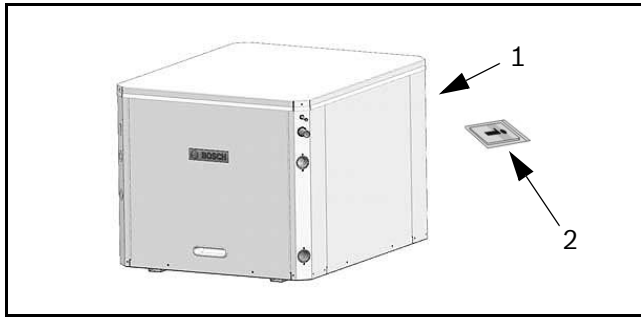

Fig. 2 SM Split Series Water-to-Air Heat Pump

[1] SM Split Series Water-to-Air Heat Pump Condensing Section

[2] Installation and Operation Manual

General Description

SM Split Series Water-to-Air Heat Pumps provide the best combination of performance and efficiency available. All units are performance certified to American Heating and Refrigeration Institute (AHRI) ISO Standard 13256-1. All SM Water-to-Air Heat Pumps conform to UL1995 standard and are certified to CAN/CSA C22.1 No 236 by Intertek-ETL.

Split system heat pumps consist of two independently installed sections allowing for centralized air distribution while remotely locating the section containing the compressor and water-to-refrigerant heat exchanger.

In the cooling mode, the air coil in the air handler section serves as an evaporator and the water-to-refrigerant heat exchanger serves as a condenser. In the heating mode, their roles are reversed.

In cooling mode, the refrigerant lines connecting the two sections consist of one line carrying liquid refrigerant and another carrying refrigerant vapor. The liquid carrying line will be referred to as the liquid line while the vapor carrying line will be referred to as the suction line.

The Water-to-Air Heat Pumps are designed to operate with entering fluid temperature between 20°F to 80°F in the heating mode and between 50°F to 110°F in the cooling mode.



A heat pump operating under extreme conditions will have limitations on air/fluid flow rates and/or temperatures.

NOTICE: 50° F Minimum Entering Water Temperature (EWT) is recommended for water applications with sufficient water flow to prevent freezing. Antifreeze solution is required for all closed-loop applications and EWT below 50°F.

Cooling Tower/Boiler and Geothermal applications should have sufficient antifreeze solution to protect against extreme conditions and equipment failure. Frozen water coils are not covered under warranty. Other equivalent methods of temperature control are acceptable.

Safety devices are built into each unit to provide the maximum system protection possible when properly installed and maintained.

Moving and Storage

If the equipment is not needed for immediate installation upon its arrival at the job site, it should be left in its shipping carton and stored in a clean and dry area. Units must only be stored or moved in the normal upright position as indicated by the “UP” arrows on each carton at all times.

Initial Inspection

Be certain to inspect all cartons or crates on each unit as received at the job site before signing the freight bill. Verify that all items have been received and that there are no visible damages; note any shortages or damages on all copies of the freight bill. In the event of damage or shortage, remember that the purchaser is responsible for filing the necessary claims with the carrier. Concealed damages not discovered until after removing the units from the packaging must be reported to the carrier within 24 hours of receipt.

UNIT INSTALLATION

This section contains information on the following:

Subject	Page
Location Selection	7
Installation	7
Piping	8
Electrical	15
Safety Devices and the UPM Controller	16
Specific Application Considerations	20
Post-Installation System Checkout	21

NOTICE: To avoid equipment damage, DO NOT use these units as a source of heating or cooling during the construction process. Doing so may affect the unit's warranty. The mechanical components and filters will quickly become clogged with construction dirt and debris, which may cause system damage.

LOCATION SELECTION

To maximize system performance, efficiency and reliability, and to minimize installation costs, it is always best to keep the refrigerant lines as short as possible. Every effort should be made to locate the air handler and the condensing section as close as possible to each other.

NOTICE: These units are not approved for outdoor installation; therefore, they must be installed inside a structure in a conditioned space. Do not locate in areas that are subject to freezing.

Condensing Section Location

Locate the condensing section in an area that provides sufficient room to make water and electrical connections, and allows easy removal of the access panels, for service personnel to perform maintenance or repair. The condensing section is designed for indoor use only.

Air Handler Location

Locate the air handler unit in an indoor area that allows easy removal of the filter and access panels, and has enough room for service personnel to perform maintenance or repair. Provide sufficient room to make electrical and duct connections. If the unit is located in a confined space such as a closet, provisions must be made for return air to freely enter that space.



Reference the individual installation and operational manuals for your SM AH/AV, BVA2.0, or BMAC for detailed instructions.

INSTALLATION



Loosen compressor mounting bolts.

NOTICE: The installer must comply with all local codes and regulations which govern the installation of this type of equipment. Local codes and regulations take precedent over any recommendations contained in these instructions.



WARNING: The equipment must be installed in accordance with the recommendations made by the National Electric Code, and in accordance with the recommendations made by the National Board of Fire Underwriters.

Condensing Section Installation

The condensing section must be mounted on a vibration absorption pad on a cement slab or similar support to provide a good base and some degree of levelness. The cement pad should not come in contact with the foundation or side of the dwelling, because sound may be transmitted into the residence. See Fig. 3 below.



DO NOT remove the protective caps or plugs from the service valves until the refrigerant lines are run and ready for final connections.

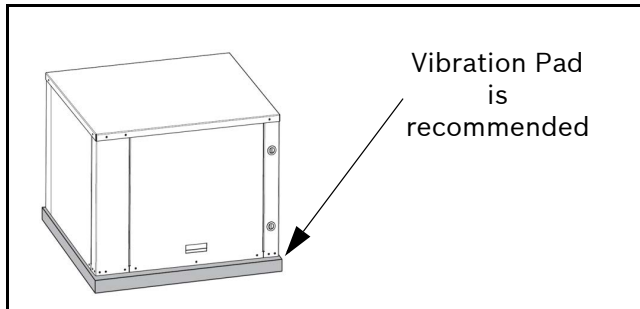

Fig. 3 Vibration Pad

Condensate Drain

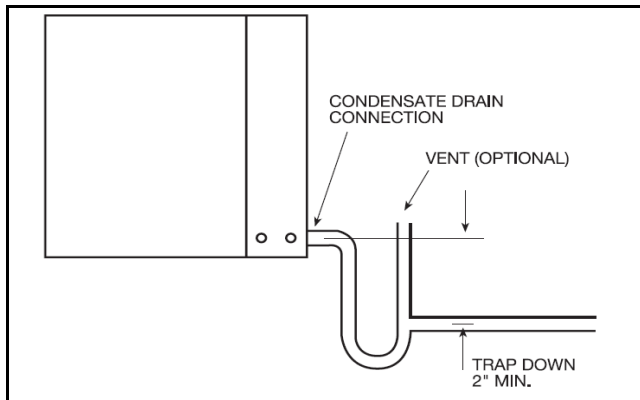
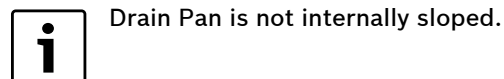

Fig. 4 Condensate Drain

A drain line must be connected to the air handler and pitched away from the unit a minimum of 1/8" per foot to allow the condensate to flow away from the unit.

This connection must be in conformance with local plumbing codes. A trap must be installed in the condensate line to ensure free condensate flow.



Drain Pan is not internally sloped.

A vertical air vent is sometimes required to avoid air pockets. The length of the trap depends on the amount of positive or negative pressure on the drain pan. A second trap must not be included.

Water Piping

Supply and return piping must be as large as the unit connections on the heat pump (See Table #2 for any line size with an installation 25 feet and longer).

Use flexible hoses between the unit and the rigid system to avoid possible vibration.

NOTICE: Never use flexible hoses of a smaller inside diameter than that of the fluid connections on the unit.

SM units are supplied with either a copper or optional cupro-nickel condenser. Copper is adequate for ground water that is not high in mineral content. Refer to the Water Quality table on page #14.



Proper testing is required to ensure the well water quality is suitable for use with water source equipment.

In conditions anticipating moderate scale formation or in brackish water a cupro-nickel heat exchanger is required. Refer to the Water Quality table on page #14. Water quality must meet the standards stated in the table.

Both the supply and discharge water lines will sweat if subjected to low-water temperature. These lines must be insulated to prevent damage from condensation.

All manual flow valves used in the system must be ball valves (supplied by others). Globe and gate valves must not be used due to their high-pressure drop and poor throttling characteristics.

Install ball valves in the supply and return lines for unit isolation and unit water flow balancing.

NOTICE: Never exceed the recommended water-flow rates, as serious damage or erosion of the water-to-refrigerant heat exchanger could occur. Refer to the Bosch SM Split CS ESS (Engineer Submittal Sheet) for water-flow rates. (See <https://www.bosch-thermotechnology.us/us/en/residential/home/>)

Always check carefully for water leaks and repair appropriately. Units are equipped with female pipe thread fittings. Consult Unit Dimensional Drawings on page #40.



To prevent leaks and possible heat exchanger fouling, use Teflon tape sealer when connecting water piping connections to the unit.

NOTICE: Do not overtighten the connections.

REFRIGERANT LINES

The installation of the copper refrigerant tubing must be done with care to obtain reliable, trouble-free operation.

This installation should only be performed by qualified refrigeration service and installation personnel.

Refrigerant lines generally must be routed and supported so as to prevent the transmission of vibrations into the building structure. Experience and good design practice dictate 75 feet as the maximum practical length for interconnecting refrigerant lines in split system heat pumps without special considerations.

Beyond 75 feet, system losses become substantial and the total refrigerant charge required compromises the reliability and design life of the equipment.

Copper tubing be clean and free of moisture and dirt or debris. The suction and liquid lines MUST be insulated with at least 3/8" wall, closed-cell foam rubber insulation or the equivalent.

Some points to consider are:

- Pressure drop (friction losses) in refrigerant suction lines reduces system capacity and increases power consumption by as much as 2% or more, depending on the line length, number of bends, etc. Pressure drop in liquid lines affects system performance to a lesser degree, provided that a solid column of liquid (no flash gas) is being delivered to the refrigerant metering device, and that the liquid pressure at the refrigerant metering device is sufficient to produce the required refrigerant flow.

- Oil is continually being circulated with the refrigerant so, oil return to the compressor is always a consideration in line sizing. Suction lines on split system heat pumps are also hot gas lines in the heating mode, but are treated as suction lines for sizing purposes. If the recommended suction lines sizes are used, there should be no problem with oil return.
- Vertical lines should be kept to a minimum. Vertical liquid lines will have a vertical liquid lift in either heating or cooling, and the weight of the liquid head is added to the friction loss to arrive at the total line pressure drop.
- Wherever possible, the air handler should be installed at a higher elevation than the condensing section to aid with oil return to the compressor.

Linear vs. Equivalent Line Length

Linear Line Length — is the actual measured length of the line including bends. This is used to calculate the additional refrigerant charge that must be added to the system (See Tables #2 through Table #5 for charge adjustments, and examples).

Equivalent Line Length — is the combination of the actual length of all the straight runs and the equivalent length of all bends valves and fittings in a particular line. The equivalent length of a bend, valve or fitting is equal to the length of a straight tube of the same diameter having the same pressure drop as the particular valve or fitting. The ASHRAE Fundamentals Handbook provides tables for determining the equivalent length of various bends, valves and fittings.

Connecting Refrigerant Lines

- Use only ACR grade copper tubing and keep ends sealed until joints are made.
- For best performance, select routing of refrigerant lines for minimum distance and fewest number of bends.
- Size lines in accordance with Table #2.
- Cut crimped ends off the air handler suction and liquid lines. Connect and braze lines to the air handler.



The air handler is factory supplied with a holding charge of dry nitrogen.

NOTICE: A filter drier is already installed from factory in the SM Split Condensing section unit. No additional/external filter drier required.

- Connect and braze lines to service valves on the condensing section.

NOTICE: Always wrap the body of the service valve with a wet towel or apply some other form of heat sink prior to brazing and direct flame away from the valve body. Failure to do so will result in damage to the valve. Valve body temperature must remain below 250°F to protect the internal rubber “O” rings and seals.

Valve Sizing Chart

Unit Size	Line Type	Valve Conn. Size	Hex (Allen) Wrench Size
SM024/036	Suction	3/4	5/16
SM048/060	Suction	7/8	5/16
ALL	Liquid	3/8	3/16

Table 1 Valve Sizing Chart

Pressurize the refrigerant line set and air handler to 150lbs with dry nitrogen through the ports provided on the self service valves. Check line set and unit connections for leaks.

Once system integrity is verified, evacuate line set and air handler with a good vacuum pump to 500 microns and hold for half hour.



Pump down must never be used with heat pumps.

Refrigerant Charge, Line Sizing, and Capacity Multiplier Chart

System Models	Factory R410A Charge (Oz)*	Refrigerant Line O.D. Size (Based on Equivalent Line Length)										Suction Line Riser Max.
		25 FT.		36 FT.		45 FT.		50 FT.		75 FT.		
		LIQ.	SUC.	LIQ.	SUC.	LIQ.	SUC.	LIQ.	SUC.	LIQ.	SUC.	
SM024	80	3/8	3/4	3/8	3/4	3/8	3/4	3/8	3/4	3/8	7/8	3/4
SM036	86	3/8	3/4	3/8	3/4	3/8	3/4	3/8	7/8	3/8	7/8	3/4
SM048	88	3/8	7/8	3/8	7/8	3/8	7/8	3/8	7/8	3/8	7/8	7/8
SM060	115	3/8	1-1/8	3/8	1-1/8	3/8	1-1/8	3/8	1-1/8	3/8	1-1/8	7/8
CAPACITY MULTIPLIER		1.00		0.995		0.990		0.990		0.980		
EXAMPLE 1: Model SM036 with 45 ft. of equivalent length of 3/8" O.D. Liquid Line. Total System Charge= Factory Charge + (45 ft. - 25 ft.) x .60 oz./ft. Total System Charge = 93 oz. + (20 ft. x .60 oz./ft.) = 105 oz. Additional 12 oz. of R410A refrigerant required.						EXAMPLE 2: Model SM060 with 10 ft. of equivalent length of 3/8" O.D. Liquid Line. Total system charge= Factory charge + (25 ft. -10 ft.) x .60 oz./ft. Total System Charge = 150 oz. + (15 ft. x .60 oz./ft.) = 141 oz. Additional 12 oz. of R410A refrigerant required.						

Table 2 Refrigerant Charge, Line Sizing, and Capacity Multiplier Chart

Liquid Line Charge per Linear Foot

LIQUID LINE SIZE, O.D.	1/4	5/16	3/8	1/2	5/8
R410A OZ PER FOOT	.25	.44	.60	1.15	1.95

Table 3 Liquid Line Charge per Linear Foot

Additional Adjustments Required when Pairing SM Split CS with BVA2.0 and BMAC

- Adjust factory charge as per Table #4 or Table #5 as appropriate, and then proceed with additional charge adjustment calculations by line size as per Table #2.
- Adjust TXV as per Table #6 or Table #7, as appropriate.
- Adjust BVA motor setting as per Table #8 to obtain the rated airflow. Refer to the BVA2.0 operational manual for additional airflow settings.

Charge Adjustments (oz) for SM Split CS when Paired with BOSCH BVA2.0

CS MODEL	Air Handler Model			
	BVA-24WN1-M20	BVA-36WN1-M20	BVA-48WN1-M20	BVA-60WN1-M20
SM024-1CSC	-6			
SM024-1CSN	-9			
SM036-1CSC		0		
SM036-1CSN		0		
SM048-1CSC			13	
SM048-1CSN			8	
SM060-1CSC				0
SM060-1CSN				0

Table 4 Charge Adjustments (oz) for SM Split CS when Paired with BOSCH BVA2.0

Charge Adjustments (oz) for SM Split CS when Paired with BOSCH BMAC

CS MODEL	Cased/Uncased Coil Model			
	BMAC2430BNTD	BMAC3036BNTD	BMAC4248CNTF	BMAC4860CNTF
SM024-1CSC	-10			
SM024-1CSN	-11			
SM036-1CSC		-4		
SM036-1CSN		-4		
SM048-1CSC			12	
SM048-1CSN			10	
SM060-1CSC				10
SM060-1CSN				10

Table 5 Charge Adjustments (oz) for SM Split CS when Paired with BOSCH BMAC

TXV Adjustments for SM Split CS when Paired with BOSCH BVA2.0

CS MODEL	Air Handler Model			
	BVA-24WN1-M20	BVA-36WN1-M20	BVA-48WN1-M20	BVA-60WN1-M20
SM024-1CSC	None			
SM024-1CSN	None			
SM036-1CSC		SM: 1 Turn Closed BVA: None		
SM036-1CSN		SM: 1 Turn Closed BVA: None		
SM048-1CSC			SM: 1 Turn Closed BVA: None	
SM048-1CSN			SM: 1 Turn Closed BVA: None	
SM060-1CSC				SM: 1 Turn Closed BVA: None
SM060-1CSN				SM: 1 Turn Closed BVA: None

Table 6 TXV Adjustments for SM Split CS when Paired with BOSCH BVA2.0

TXV Adjustments for SM Split CS when Paired with BOSCH BMAC

CS MODEL	Cased/Uncased Coil Model			
	BMAC2430BNTD	BMAC3036BNTD	BMAC4248CNTF	BMAC4860CNTF
SM024-1CSC	None			
SM024-1CSN	None			
SM036-1CSC		SM: 1 Turn Closed BMAC: None		
SM036-1CSN		SM: 1 None BMAC: None		
SM048-1CSC		SM: 1 Turn Closed BMAC: None		
SM048-1CSN		SM: 1 Turn Closed BMAC: None		
SM060-1CSC				SM: None BMAC: 1 Turn Closed
SM060-1CSN				SM: None BMAC: 1 Turn Closed

Table 7 TXV Adjustments for SM Split CS when Paired with BOSCH BMAC

BVA2.0 Rated Airflow Adjustment when Paired with SM Split CS Models

CS Model	Air Handler	Full-Load-Rated Airflow	Part-Load-Rated Airflow	Blower Setting (High/Low)
SM024-1CS	BVA24	900	600	5/3
SM036-1CS	BVA36	1200	900	5/3
SM048-1CS	BVA48	1600	1200	4/2
SM060-1CS	BVA60	1700	1400	5/3

Table 8 BVA2.0 Rated Airflow Adjustment when Paired with SM Split CS Models

WATER QUALITY TABLE

Water Quality			
POTENTIAL PROBLEM	Water Characteristic	Acceptable Value	
		Copper	Cupro-Nickel
	pH (Acidity/Alkalinity)	7–9	7–9
SCALING	Hardness (CaCO ₃ , MgCO ₃)	< 350 ppm	< 350 ppm
	Ryznar Stability Index	6.0–7.5	6.0–7.5
	Langelier Saturation Index	-0.5 – +0.5	-0.5 – +0.5
CORROSION	Hydrogen Sulfide (H ₂ S)	< 0.5 ppm*	10–50 ppm
	Sulfates	< 125 ppm	< 125 ppm
	Chlorine	< 0.5 ppm	< 0.5 ppm
	Chlorides	< 20 ppm	< 150 ppm
	Carbon Dioxide	< 50 ppm	< 50 ppm
	Ammonia	< 2 ppm	< 2 ppm
	Ammonia Chloride	< 0.5 ppm	< 0.5 ppm
	Ammonia Nitrate	< 0.5 ppm	< 0.5 ppm
	Ammonia Hydroxide	< 0.5 ppm	< 0.5 ppm
	Ammonia Sulfate	< 0.5 ppm	< 0.5 ppm
	Dissolved Solids	< 1,000 ppm	< 1,500 ppm
IRON FOULING	Iron (Fe ₂ + Iron Bacteria Potential)	< 0.2 ppm	< 0.2 ppm
	Iron Oxide	< 1 ppm	< 1 ppm
EROSION	Suspended Solids	< 10 ppm, < 600 μm size**	< 10 ppm, < 600 μm size**
	Maximum Water Velocity	6 ft/sec	6 ft/sec
* No "rotten egg" smell present at < 0.5 ppm H ₂ S.			
** Equivalent to 30 mesh strainer			

Table 9 Water Quality

Electrical

Refer to electrical component box layout. (See Fig. 5)



DANGER: UNIT OPERATION AND SAFETY HAZARD

Field wiring must comply with local and national electric codes.



WARNING: UNIT OPERATION AND SAFETY HAZARD

Properly-sized fuses or HACR circuit breakers must be installed for branch circuit protection. See the unit nameplate for maximum fuse or breaker size.



DANGER: UNIT OPERATION AND SAFETY HAZARD

Power to the unit must be within the operating voltage range indicated on the unit's nameplate or on the performance data sheet.

NOTICE: Operation of unit on improper line voltage or with excessive phase imbalance will be hazardous to the unit, constitutes abuse and may void the warranty.

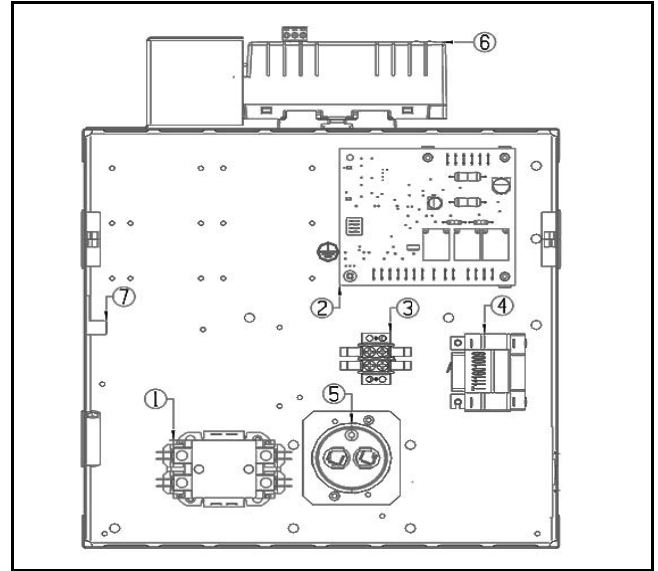

Fig. 5 Electrical Component Box Layout

- [1] Compressor Contactor
- [2] Unit Protection Module (UPM)
- [3] Low-Voltage Terminal Block
- [4] Pump/Valve Relay
- [5] Capacitor
- [6] SmartStart Assist (Field-Installed Accessory)
- [7] Grounding Lug

The unit is provided with a concentric knock-out for attaching common trade sizes of conduit. Route power supply wiring through this opening. Always connect the ground lead to the grounding lug provided in the control box and power leads to the line side of compressor contactor as indicated on the wiring diagrams starting on page #38.

Safety Devices and the UPM Controller

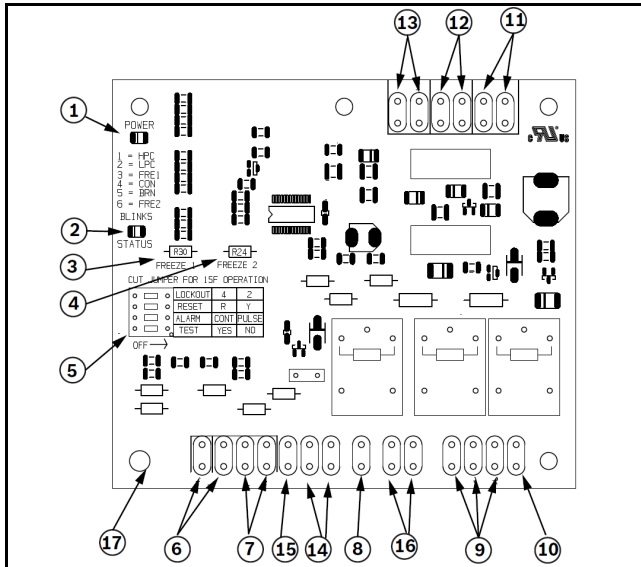

Fig. 6 Typical UPM controller board

- [1] Board Power Indicator
- [2] UPM Status LED Indicator (Fault Status)
- [3] Water Source Coil Freeze Protection Temperature Selection (R30, FREEZE 1)
- [4] Load Water Coil Freeze Protection Temperature Selection (R24, FREEZE 2)
- [5] UPM Board Settings
- [6] Source Coax Freeze Connection (FREEZE 1)
- [7] Load Coax Freeze Connection (FREEZE 2)
- [8] LCD Unit Display Connection
- [9] 24VAC Power Input (R)
- [10] Compressor Contact Output
- [11] High-Pressure Switch Connection
- [12] Call for Compressor (Y1 Output)
- [13] Low-Pressure Switch Connection
- [14] 24VAC Power Common (C)
- [15] Condensate Overflow Sensor
- [16] Dry Contact
- [17] UPM Ground Standoff



When a malfunction light is used for diagnostic purposes, the connection is made at the dry contact connection terminals of the UPM board. Refer to Fig. 6.



If the thermostat is provided with a malfunction light powered off of the common (C) side of the transformer, a jumper between “R” and “COM” terminal of alarm (ALR) contacts must be installed.

Each unit is provided with a factory-installed Unit Protection Module (UPM) that controls the compressor operation and monitors the safety controls that protect the unit.

Safety controls include the following:

- High-pressure switch located in the refrigerant discharge line and wired across the HPC terminals on the UPM.
- Low-pressure switch located in the unit refrigerant suction line and wired across terminals LPC1 and LPC2 on the UPM.
- Water-side freeze protection sensor, mounted close to condensing water coil, monitors refrigerant temperature between condensing water coil and thermal expansion valve. If temperature drops below or remains at freeze limit trip for 30 seconds, the controller will shut down the compressor and enter into a soft-lockout condition. The default freeze limit trip is 26°F; however, this can be changed to 15°F by cutting the R30 or FREEZE 1 resistor located on top of DIP switch SW1 (Refer to Fig. 6, item [3] for resistor location), refer to Fig. 7 for sensor location.



The UPM Board Dry Contacts are Normally Open (NO).

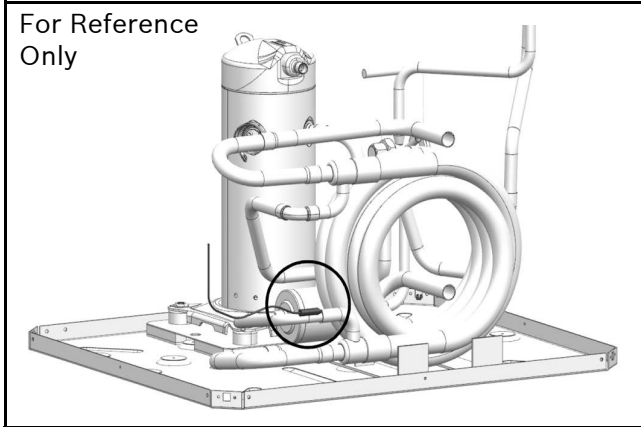

Fig. 7 Sensor location

NOTICE: If the unit is employing a fresh water system (no anti-freeze protection), it is extremely important to have the Freeze 1 R30 resistor set to 26°F in order to shut down the unit at the appropriate leaving water temperature and protect your heat pump from freezing if a freeze sensor is included.

- The condensate overflow protection sensor is located in the drain pan of the unit and connected to the “COND” terminal on the UPM board. (Refer to Fig. 8)

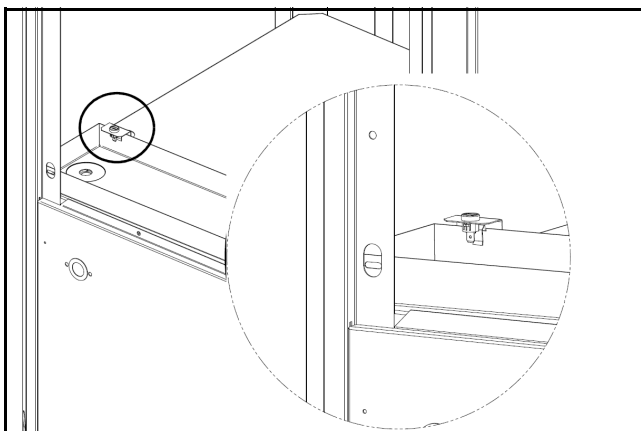

Fig. 8 Condensate Overflow Protection Sensor

UPM Board Factory Default Settings	
TEMP	26°F
LOCKOUT	2
RESET	Y
ALARM	PULSE
TEST	NO

Table 10 UPM Board Factory Default Settings

UPM DIP SWITCH SELECTABLE POSITIONS			
	Lockout	4	2
	Reset	R	Y
	Alarm	Cont	Pulse
	Test	Yes	No

Table 11 UPM DIP Switch Selectable Positions

The UPM Board includes the following features:

- ANTI-SHORT CYCLE TIMER:** Five-minute delay on break timer to prevent compressor short cycling.
- RANDOM START:** Each controller has a unique random start delay ranging from 270 to 300 seconds on initial power up to reduce the chance of multiple unit simultaneously starting at the same time after power up or after a power interruption, thus avoiding creating large electrical spike.
- LOW-PRESSURE BYPASS TIMER:** If the compressor is running and the low-pressure switch opens, the controller will keep the compressor ON for 120 seconds. If after 120 seconds the low-pressure switch remains open, the controllers will shut down the compressor and enter a soft lockout. The compressor will not be energized until the low-pressure switch closes and the anti-short cycle time delay expires. If the low-pressure switch opens 2 or 4 times in 1 hour, the unit will enter a hard lockout. In order to exit the hard lockout, power to the unit would need to be reset. The reset signal is either a Y or R signal depending on the position of the dip switch as shown in Table #11. If the reset is set

to R, the board must be manually powered off and powered back on to exit the hard lock out.

- **BROWNOUT/SURGE/POWER INTERRUPTION PROTECTION:** The brownout protection in the UPM board will shut down the compressor if the incoming power falls below 18 VAC. The compressor will remain OFF until the voltage is above 18 VAC and ANTI-SHORT CYCLE TIMER (300 seconds) times out. The unit will not go into a hard lockout.
- **MALFUNCTION OUTPUT:** Alarm output is Normally Open (NO) dry contact. If pulse is selected the alarm output will be pulsed. The fault output will depend on the dip switch setting for "ALARM." If it is set to "CONST," a constant signal will be produced to indicate a fault has occurred and the unit requires inspection to determine the type of fault. If it is set to "PULSE," a pulse signal is produced and a fault code is detected by a remote device indicating the fault. For blink code explanation, see Table #15 on page #31. The remote device must have a malfunction detection capability when the UPM board is set to "PULSE."



If 24 VAC output is needed, R must be wired to ALR-COM terminal; 24 VAC will be available to the ALR-OUT terminal when the unit is in the alarm condition.

- **TEST DIP SWITCH:** A test dip switch is provided to reduce all time delays settings to 10 seconds during troubleshooting or verification of unit operation.

NOTICE: Operation of unit in test mode can lead to accelerated wear and premature failure of components. The "TEST" switch must be set back to "NO" after troubleshooting/servicing.

- **FREEZE SENSOR:** The default setting for the freeze limit trip is 30°F (sensor number 1); however, this can be changed to 15°F by cutting the R24 resistor located on top of the DIP switch SW1. Since Freeze Sensor 2 is dedicated to monitor the load side coil it is recommended to leave the factory default setting on the board. The UPM controller will constantly monitor the refrigerant temperature with the sensor mounted close to the condensing water coil between the thermal expansion valve and water coil. If temperature

drops below or remains at the freeze-limit trip for 30 seconds, the controller will shut the compressor down and enter into a soft-lockout condition. Both the status LED and the Alarm contact will be active. The LED will flash (3 times) the code associated with this alarm condition. If this alarm occurs 2 times (or 4 if Dip switch is set to 4) within an hour the UPM controller will enter into a hard-lockout condition. It will constantly monitor the refrigerant temperature with the sensor mounted close to the evaporator between the thermal expansion valve and evaporator coil as shown in Fig. 7. If temperature drops below or remains at the freeze limit trip for 30 seconds, the controller will shut the compressor down and enter into a soft-lockout condition. Both the status LED and the Alarm contact will be active. The LED will flash 6 times, the code associated with this alarm condition. If this alarm occurs 2 times (or 4 if Dip switch is set to 4) within an hour the controller will enter into a hard-lockout condition.

NOTICE: The freeze sensor will not guard against the loss of water. To prevent unit from running if water flow is lost or reduced, install a flow switch.

- **INTELLIGENT RESET:** If a fault condition is initiated, the five-minute delay on break time period is initiated and the unit will restart after these delays expire. During this period the fault LED will indicate the cause of the fault. If the fault condition still exists or occurs 2 or 4 times (depending on 2 or 4 setting for Lockout dip switch) before 60 minutes, the unit will go into a hard lockout and requires a manual lockout reset. A single condensate overflow fault will cause the unit to go into a hard lockout immediately, and will require a manual lockout reset.
- **LOCKOUT RESET:** A hard lockout can be reset by turning the unit thermostat off and then back on when the "RESET" dip switch is set to "Y" or by shutting off unit power at the circuit breaker when the "RESET" dip switch is set to "R."



The blower motor will remain active during a lockout condition.

TYPICAL SYSTEM SETUP

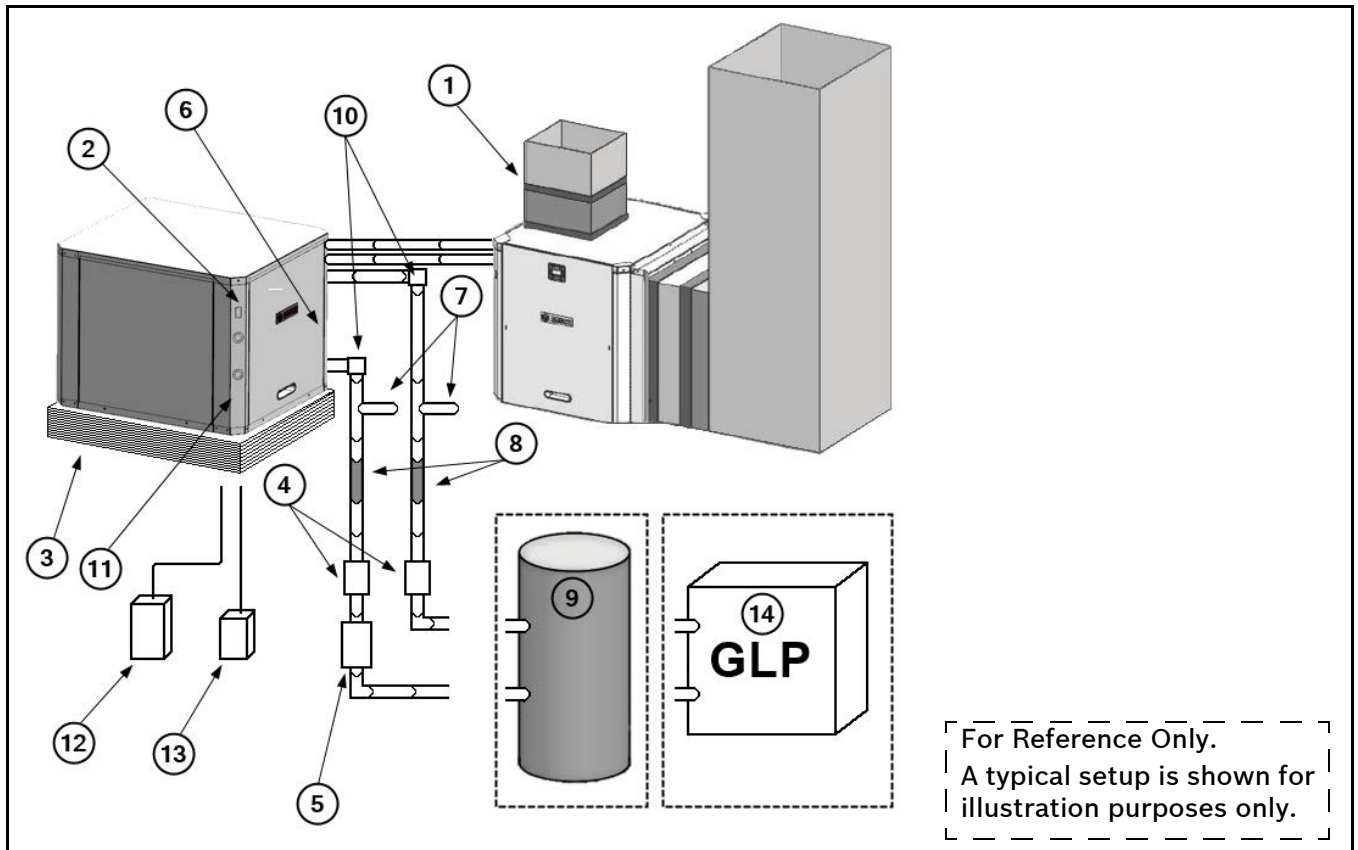

Fig. 9 Typical system setup

- [1] Flex Duct Connection
- [2] Low Voltage Control Connection
- [3] Vibration Pad
- [4] Ball Valves
- [5] Solenoid Valve Slow Closing
- [6] Condensate Drain Connection
- [7] Drain Valves
- [8] Hose Kits (optional)
- [9] Pressure Tank (optional)
- [10] P/T Ports (optional)
- [11] Line Voltage Connection
- [12] Electric Heater Line Voltage Disconnect
- [13] Unit Line Voltage Disconnect
- [14] Ground Loop Pumping Package

SPECIFIC APPLICATION CONSIDERATIONS

Well Water Systems

Copper is adequate only for ground water that is not high in mineral content. Proper testing to ensure that the well water quality is suitable for use with water source equipment is required. (See the Water Quality table on page #14.) In conditions anticipating moderate scale formation or in brackish water a cupro-nickel heat exchanger is required. In well water applications, water pressure must always be maintained in the heat exchanger. This can be accomplished with either a control valve or a bladder-type expansion tank. When using a single water well to supply both domestic water and the heat pump, care must be taken to ensure that the well can provide sufficient flow for both. In well water applications, a slow-closing solenoid valve must be used and installed on the leaving-water side of coaxial to prevent water hammering. Solenoid valves must be connected across Y1 and C1 on the interface board for all. Make sure that the VA draw of the valve does not exceed the contact rating of the thermostat.

Cooling Tower/Boiler Systems

The cooling tower and boiler water loop temperature is usually maintained between 50°F to 100°F to ensure adequate cooling and heating performance. In the cooling mode, heat is ejected from the unit into the water loop. A cooling tower provides evaporative cooling to the loop water thus maintaining a constant supply temperature to the unit. When utilizing open cooling towers, chemical water treatment is mandatory to ensure the water is free from corrosive elements. A secondary heat exchanger (plate frame) between the unit and the open cooling tower may also be used.

It is imperative that all air be eliminated from the closed-loop side of the heat exchanger to ensure against fouling. In the heating mode, heat is absorbed from the water loop. A boiler can be utilized to maintain the loop at the desired temperature.

Cooling Tower/Boiler Systems Piping

NOTICE: Water piping exposed to extreme low ambient temperatures is subject to freezing.



Teflon tape sealer must be used when connecting to the unit to insure against leaks and possible heat exchanger fouling.

Consult Bosch SM split CS ESS (Engineer Submittal Sheet) for pipe connection sizes. (See <https://www.bosch-thermotechnology.us/us/en/residential/home/>)



Do not overtighten the connections.

Flexible hoses must be used between the unit and the rigid system to avoid possible vibration.

Ball valves must be installed in the supply and return lines for unit isolation and unit water flow balancing.

Pressure/temperature ports are recommended in both supply and return lines for system flow balancing. Water flow can be accurately set by measuring the water-to-refrigerant heat exchangers' water-side pressure drop. (See Table #21, on page #36, for water flow vs. pressure drop information.)

Do not connect the unit to the supply or return piping until the water system has been completely cleaned and flushed to remove any dirt, piping chips, or other foreign material. Connect the supply and return hoses together during this process to ensure the entire system is properly flushed. After the cleaning and flushing has taken place, the unit may be connected to the water loop with all valves fully open.

Geothermal Systems

Closed-loop and pond applications require specialized design knowledge. No attempt at these installations should be made unless the dealer has received specialized training. Using the Ground Loop Pumping Package (GLP), makes the installation easy. Anti-freeze solutions are utilized when low-evaporating conditions are expected to occur. Refer to the GLP installation manuals for specific instructions.

POST-INSTALLATION SYSTEM CHECKOUT

After completing the installation and before energizing the unit, the following system checks MUST be made:

1. Verify that the supply voltage to the heat pump is in accordance with the nameplate ratings.
2. Make sure that all electrical connections are tight and secure.
3. Check the electrical fusing and wiring for the correct size.



DANGER: ELECTRICAL HAZARD

Ensure the cabinet and electrical box are properly grounded.

4. Verify that the low-voltage wiring between the thermostat and the unit is correct.
5. Verify that the water piping is complete and correct.
6. Check that the water flow is correct and adjust if necessary.
7. Check the blower for free rotation, and that it is secured to the shaft.
8. Verify that vibration isolation has been provided.
9. Ensure the unit is serviceable.
10. Confirm that all access panels are secured in place.



IMPORTANT:

- Always check incoming line-voltage power supply and secondary control voltage for adequacy. Transformer primaries are dual tapped for 208 and 230 volts. Connect the appropriate tap to ensure a minimum secondary control voltage of 18 volts. 24 volts is ideal for best operation.
- Long-length thermostat and control wiring leads may create voltage drop. Increase wire gauge or up-size transformers may be required to ensure minimum secondary voltage supply.
- Bosch recommends the following guidelines for wiring between a thermostat and the unit: 18 GA up to 60 foot, 16 GA up to 100 ft and 14 GA up to 140 ft.
- Do not apply additional controlled devices to the control circuit power supply without consulting the Bosch Thermotechnology Corp. Doing so may void equipment warranties.
- Check with all code authorities on installation criteria including condensate disposal/overflow protection criteria.

SYSTEM OPERATION

UNIT START-UP

1. Place the UPM board in “Test” mode.
2. Set the thermostat to the highest setting.
3. Set the thermostat system switch to “COOL” and the fan switch to the “AUTO” position. The reversing valve solenoid should energize. The compressor should not run.
4. Reduce the thermostat setting approximately five degrees below the room temperature.
5. Verify the heat pump is operating in the cooling mode.
6. Turn the thermostat system switch to the “OFF” position. The unit should stop running and the reversing valve should de-energize.
7. Leave the unit off for approximately five minutes to allow for system equalization.
8. Turn the thermostat to the lowest setting.
9. Set the thermostat switch to “HEAT.”
10. Increase the thermostat setting approximately five degrees above the room temperature.
11. Verify the heat pump is operating in the heating mode.
12. Set the thermostat to maintain the desired space temperature.
13. Check for vibrations, leaks, etc.

SEQUENCE OF OPERATION

Cooling Mode

Energizing the “O” terminal energizes the unit reversing valve thus placing the unit into cooling mode. The fan motor starts when the “G” terminal is energized.



The fan motor takes 30 seconds to ramp up to operating speed and will run at the fan-only rated airflow, as long as there is no call for compressor or heater operation.

When the thermostat calls for first-stage cooling (Y1) the loop pump or solenoid valve, if present, is energized and the first stage of the compressor capacity starts.



Some accessories have a built-in delay, and hence, compressor operation is not immediate. See “Field-Installed Accessories” section on page #23 for more detail.

When the thermostat calls for second-stage cooling (Y2) the second stage (or full-compressor capacity) is initiated. The fan ramps up to full cooling airflow.

Once the thermostat is satisfied, the compressor shuts down and the fan ramps down to either fan-only mode or off over a span of 30 seconds.



A fault condition initiating a lockout will de-energize the compressor irrespective of which stage is engaged.

Heating Mode

The first two stages of heating (Y1 & Y2) operate in the same manner as cooling, but with the reversing valve de-energized. On a call for auxiliary heat (W1), the fan ramps up to auxiliary heat airflow immediately and the electric heater package is energized along with the compressor. As the thermostat is satisfied, the heaters will shut off as soon as W1 is de-energized, and the compressors will remain on until the thermostat stages are satisfied.



If the unit compressor locks out for any reason at this time, the electric heaters will continue to function normally.

Once the thermostat is satisfied, the compressor shuts down and the fan ramps down to either fan-only mode or off over a span of 30 seconds. If thermostat has two different output points, one for Auxiliary heat and a different one for Emergency heat, the two outputs must be terminated on W1 units equipped with one stage of Electric heat.



When using a 2-cool, 3-heat thermostat both the W1 & W2 on the Heat Pump and W2 & EM on the thermostat must be connected together via a jumper.

STANDARD FACTORY-INSTALLED COMPONENTS

Pump/Valve Relay

The factory-installed pump/valve relay can be used to energize a supply pump or solenoid valve when there is a call for compressor operation. This relay can be used to switch either high- or low-voltage power.



Fig. 10 Pump/Valve Relay

FIELD-INSTALLED ACCESSORIES

A number of field-installed accessories are available on SM Series of Heat Pumps. The following details the purpose, function, and components of each option.

Flow Proving Switch (DPS)

The water flow proving switch (DPS) is a field-installed option available for the SM Split series. The DPS prevents compressor operation if there is inadequate water flow through the water-to-refrigerant heat exchanger in the heat pump.

The DPS operates by monitoring the water-side pressure drop across the water-to-refrigerant heat exchanger. When the pressure drop between the water-in and water-out lines reaches a preset value, compressor operation is enabled.

SmartStart Assist

The SM series is available with the SmartStart Assist device as a field-installed accessory. This device reduces starting (in-rush) current for compressors by 45% to 65%. This reduction in starting current can eliminate or greatly reduce “light flickering” during compressor starts and can reduce the required size of back-up transformers. The adaptive technology of the device can also extend compressor life by providing smoother, lower currents starts and by protecting the compressor from transient over voltage and under voltage after ramp up. The SmartStart is designed for single-phase scroll compressors and can also optimize algorithms for high-pressure starts. The SmartStart Assist device is depicted in Fig. 11.

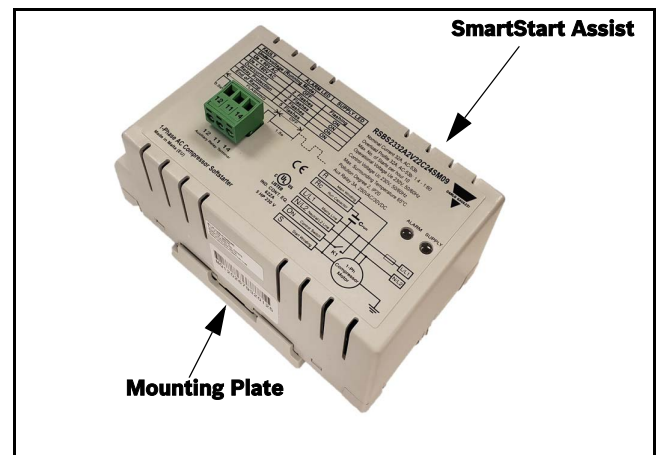

Fig. 11 SmartStart Assist Device

SmartStart Assist Specifications

SmartStart Assist Specifications	
Rated Operational Voltage:	208/230VACrms +/- 15% 50-60 Hz
Environmental Operating Range:	-4° to 149°F (-20° to 65°C); < 95% @ 40 C relative humidity, non-condensing
Degree of Protection:	IP20
Overvoltage:	Category II
Operational Rated Current:	32 Amps
Max Starting Current:	80A ACrms
Min Full Load Current:	80A ACrms
Min time between starts:	6 minutes
Min time between stop to start:	3 minutes

Table 12 SmartStart Assist Specifications

SmartStart Assist Modes of Operations

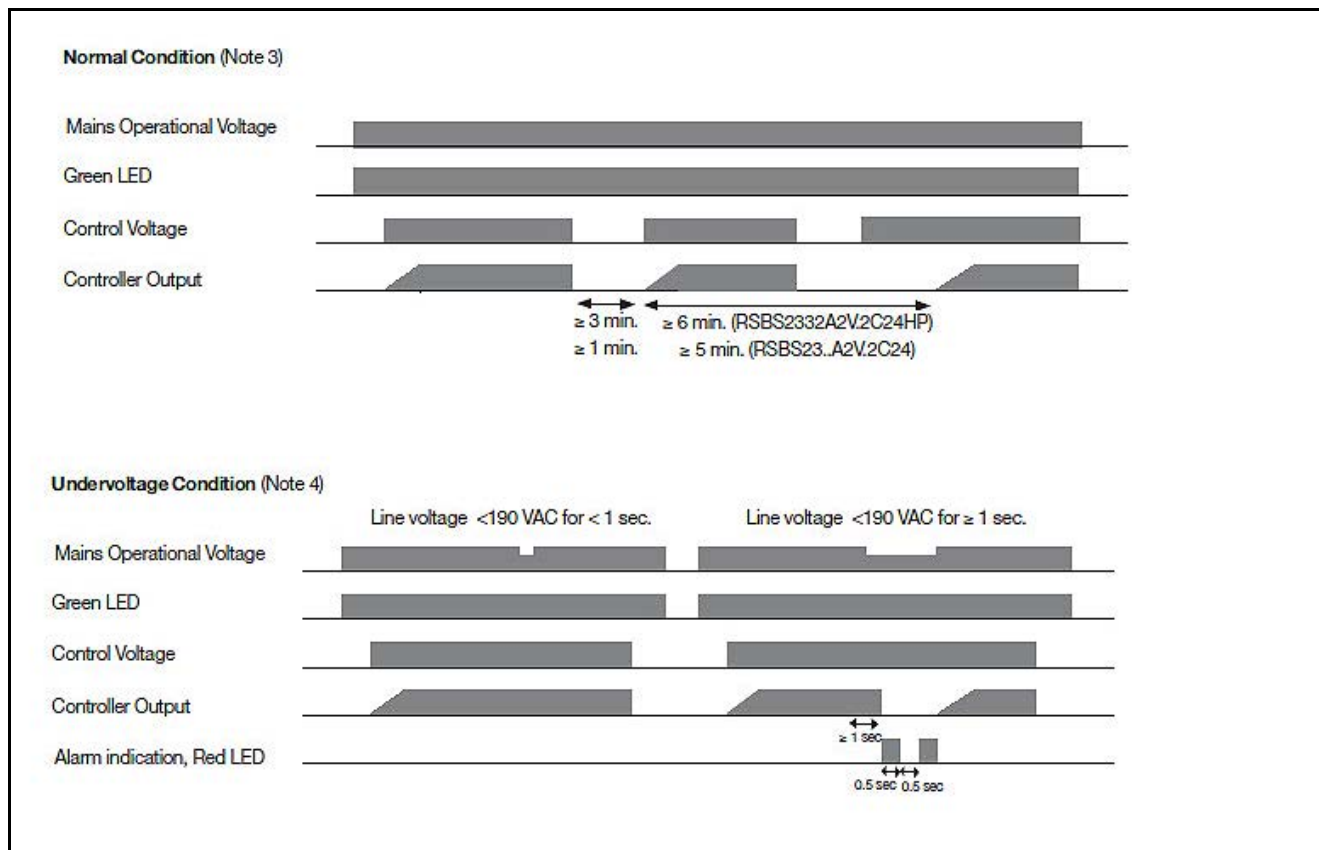

Fig. 12 SmartStart Assist Modes of Operations (Normal and Undervoltage Condition)

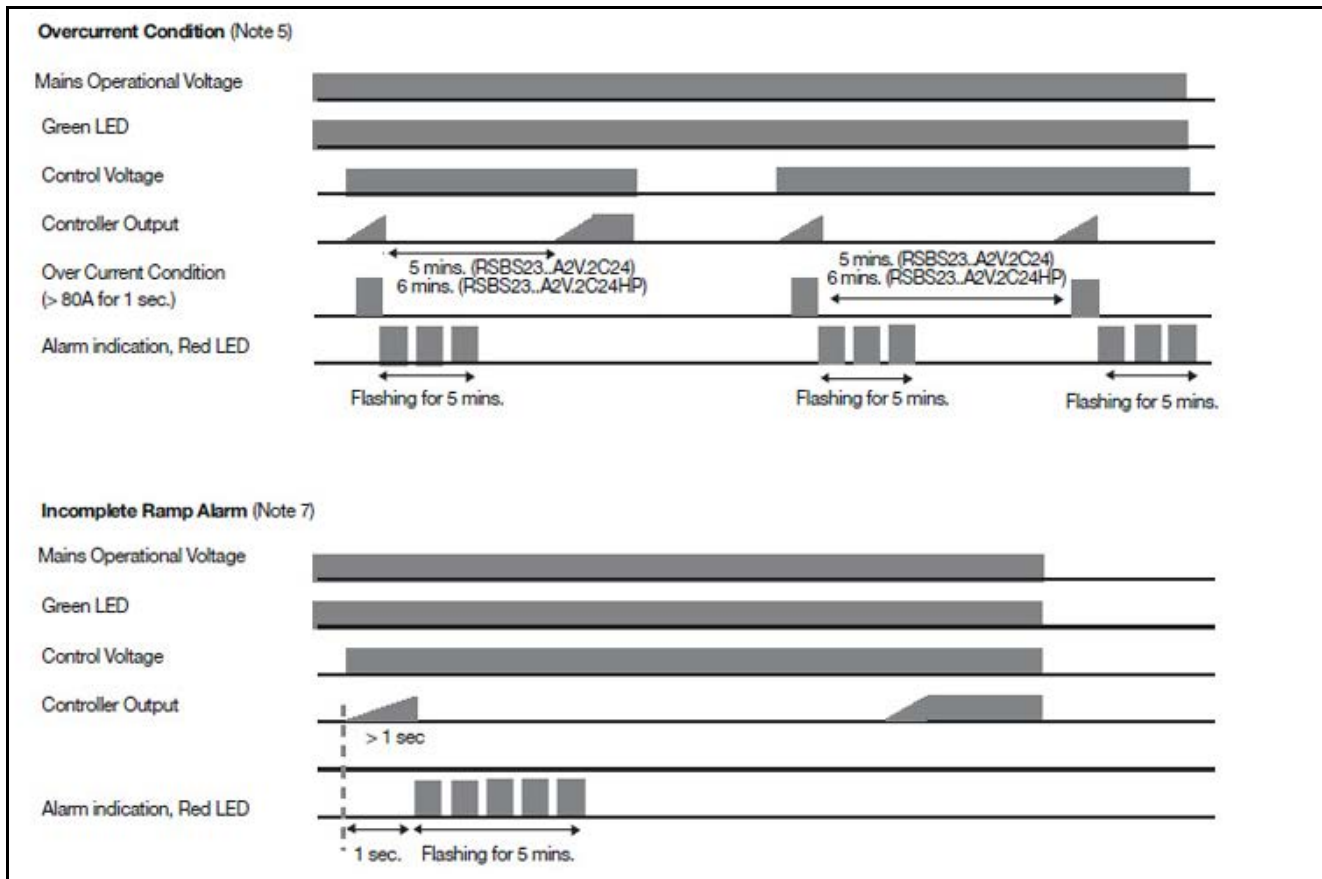

Fig. 13 SmartStart Assist Modes of Operations (Overcurrent Condition and Incomplete Ramp Alarm)

SmartStart Assist Modes of Operation Notes

1. The SmartStart Assist has two indication LEDs on board. The green LED indicates the status of the on-board power supply while the red LED indicates an alarm condition or the recovery time between starts.
2. Once the main voltage is present, the green LED will be fully ON. In case the main voltage is less than the stated pickup voltage alarm value, the green LED will be flashing. In case main voltage is higher than the stated pick-up voltage and green LED is flashing, then this may indicate that the on-board power supply is faulty. (Power Supply Alarm)
3. Upon closing L/L1, the SmartStart Assist will start ramping, duration of which is < 1 second, provided that the minimum time from stop to start is respected. When opening L/L1, the SmartStart Assist will stop without any ramp down.
4. In the case of an under voltage, the SmartStart Assist will shut down and the red LED flashes two times as long as the under voltage is present. Once the main voltage is restored the red LED will continue flashing for five minutes. Following these five minutes (six minutes for HP versions), the SmartStart Assist will start ramping function in the case L/L1 is closed. The device can be reset at any time by removing power on L2/N connection. When the power is reapplied, the soft starter will start ramping up as soon as L/L1 is closed, provided that the minimum time from stop to start are respected.
5. If an over current (>80A for 1 sec.) is sensed, the SmartStart Assist will shut down and the red LED will flash three times indicating an over current situation. This continues for five minutes. In the case that the over current is still present at the second attempt, user intervention is required to reset the controller by cycling power for the device to operate again as this implies that there are problems in the system.

6. A detection circuitry provides protection in case of a faulty starting capacitor EMR. In such situations, the red LED will flash four times for five minutes. SmartStart Assist will check the status of the starting capacitor EMR before attempting a ramping function (in the case L/L1 is closed). If at the second attempt, the starting capacitor EMR is found to be faulty, user intervention is required to reset the controller by cycling power for the device.
7. In the case of incomplete ramping of the SmartStart Assist, the red LED will flash five times. The flashing will be indicated by the red LED for five minutes. If after the second attempt, there is another incomplete ramp alarm, user intervention is required to reset the controller.
8. During the recovery from under-voltage, overcurrent, and incomplete ramp alarms, the red LED will flash twice the normal flashing frequency using the same number of flashes. Fig. 12 shows the flashing in case of a recovery from an undervoltage alarm.
9. During the recovery time between starts, the SmartStart Assist will be continuously ON until the necessary recovery time elapses.
10. If Power supply on SmartStart Assist is removed before the recovery period has elapsed, when supply is restored, the delay will continue until the remaining recovery time from the last start/stop (before supply removal) is over. Following this, another start may be attempted. If supply is removed during alarm recovery (red LED flashing), when supply is restored, the alarm will be reset and the SmartStart Assist will only wait for the respective delays between starts and/or stop to start to elapse before attempting another start (assuming L/L1 is closed).



For SmartStart Assist troubleshooting information, see page #30.

CHECK-OUT SHEET

Customer Data

Customer Name _____ Date _____
 Address _____
 Phone _____ Unit Number _____

Unit Nameplate Data

Unit Make _____
 Model Number _____ Serial Number _____
 Refrigerant Charge (oz) _____
 Compressor: RLA _____ LRA _____
 Blower Motor: FLA (or NPA) _____ HP _____
 Maximum Fuse Size (Amps) _____
 Maximum Circuit Ampacity _____

Operating Conditions

Cooling Mode

Heating Mode

Entering / Leaving Air Temp	_____ / _____	_____ / _____
Entering Air Measured at:	_____	_____
Leaving Air Measured at:	_____	_____
Entering / Leaving Fluid Temp	_____ / _____	_____ / _____
Fluid Flow (gpm)	_____	_____
Compressor Volts / Amps	_____ / _____	_____ / _____
Blower Motor Volts / Amps	_____	_____
Source Fluid Types	_____	_____
Fluid Flow (gpm)*	_____	_____
Fluid-Side Pressure Drop*	_____	_____
Suction / Discharge Pressure (psig)*	_____ / _____	_____ / _____
Suction / Discharge Temp*	_____ / _____	_____ / _____
Suction Superheat*	_____	_____
Entering TXV / Cap Tube Temp*	_____	_____
Liquid Subcooling*	_____	_____

* Required for Troubleshooting ONLY

Auxiliary Heat (If Equipped)

Unit Make _____
 Model Number _____ Serial Number _____
 Max Fuse Size (Amps) _____
 Volts / Amps _____
 Entering Air Temperature _____
 Leaving Air Temperature _____

TROUBLESHOOTING



A possible fault may be one or a combination of causes and solutions. Check each cause and adopt “process of elimination” and or verification of each before making any conclusion.

Unit Troubleshooting		
Problem	Possible Cause	Checks and Corrections
ENTIRE UNIT DOES NOT RUN	Power Supply Off	Close disconnect, apply power
	Blown Fuse/Tripped Breaker	Replace fuse or reset circuit breaker. If using fuses, ensure they are the correct size.
	Voltage Supply Low	If voltage is below minimum voltage specified on unit data plate, contact local power company.
	Thermostat	Set the fan to “ON,” the fan should run. Set thermostat to “COOL” with the lowest temperature setting, the unit should run in the cooling mode (reversing valve energized). Set unit to “HEAT” with the highest temperature setting, the unit should run in the heating mode. If neither the blower or compressor run in all three cases, the thermostat could be miswired or faulty. To ensure miswired or faulty thermostat verify that 24 volts is available on the condensing section low-voltage terminal strip between “R” and “C,” “Y” and “C,” and “O” and “C.” If the blower does not operate, verify that there is 24 volts between terminals “G” and “C” in the air handler. Replace the thermostat if defective.
UNIT OFF DUE TO HIGH-PRESSURE CONTROL	Discharge Pressure is Too High	If in “COOLING” mode: Lack of or inadequate water flow. Entering water temperature is too warm. Scaled or plugged condenser. If in “HEATING” mode: Lack of or inadequate load side fluid flow. Blower inoperative, clogged filter or restrictions in duct work.
	Refrigerant Charge	The unit is overcharged with refrigerant. Reclaim refrigerant, evacuate and recharge with the factory recommended charge.
	High-Pressure Switch	Check for a defective or improperly calibrated high-pressure switch.
UNIT OFF TO LOW-PRESSURE CONTROL	Suction Pressure Too Low	If in “COOLING” mode: Lack of or inadequate airflow. Entering air temperature is too cold. Blower inoperative, clogged filter or restrictions in duct work. If in “HEATING” mode: Lack of or inadequate water flow. Entering water temperature is too cold. Scaled or plugged condenser.
	Refrigerant Charge	The unit is low on refrigerant. Check for refrigerant leak, repair, evacuate and recharge with factory recommended charge.
	Low-Pressure Switch	Check for defective or improperly calibrated low-pressure switch.

Unit Troubleshooting		
Problem	Possible Cause	Checks and Corrections
UNIT SHORT CYCLES	Unit Oversized	Recalculate heating and or cooling loads.
	Thermostat	If the thermostat is installed near a supply air grill, relocate thermostat. Adjust the heat anticipator.
	Wiring and Controls	Check for defective or improperly calibrated low-pressure switch.
INSUFFICIENT COOLING OR HEATING	Unit Undersized	Recalculate heating and or cooling loads. If excessive, possibly adding insulation and shading will rectify the problem.
	Loss of Conditioned Air by Leakage	Check for leaks in duct work or introduction of ambient air through doors or windows.
	Airflow	Lack of adequate airflow or improper distribution of air. Replace dirty filter.
	Refrigerant Charge	Refrigerant charge low causing inefficient operation.
	Compressor	Check for defective compressor. If discharge is too low and suction pressure is too high, compressor is not pumping properly. Replace compressor.
	Reversing Valve	Defective reversing valve creating bypass of refrigerant from discharge of suction side of compressor. Replace reversing valve.
	Operating Pressures	Compare unit operation pressures to the pressure/temperature chart for the unit.
	TXV	Check TXV for possible restriction or defect. Replace if necessary.
	Moisture, Non-condensables	The refrigerant system may be contaminated with moisture or non-condensables. Reclaim refrigerant, replace filter dryer, evacuate the refrigerant system, and recharge with factory recommended charge.

Table 13 Unit Troubleshooting

SmartStart Assist Troubleshooting

Red Led	Relay Contact*	Condition	Action
FULLY ON +	11/12	Min. recovery time between starts and/or recovery time between stop to start	Auto reset when minimum recovery time elapses
2 FLASHES	11/14	Undervoltage ($U_e < 190VAC$)	Auto reset with 5 mins. recovery **
3 FLASHES	11/14	Overcurrent ($> 80A$ for > 1 sec.)	Auto reset with 5 mins. recovery
4 FLASHES	11/14	relay protection	Auto reset with 5 mins. recovery***
5 FLASHES	11/14	incomplete ramp	Auto reset with 5 mins. recovery
N/A	11/12	Supply phase loss	Physical check
N/A	11/12	Idle state	
N/A	11/12	Ramping state	
N/A	11/12	Bypass mode	
Green Led	Relay Contact*	Condition	Action
FLASHING	11/12	Power supply alarm	Replace SmartStart device
FULLY ON	11/12	Idle State	RSBS waiting for control signal to start

+ APPLICABLE TO RSBS2332A2V.2C24HP. FOR MODELS, NO INDICATION ON THE RED LED IS PROVIDED
 *APPLIES ONLY TO RSB23XXA2V22C24..MODELS
 **MONITORED DURING IDLE AND BYPASS
 ***REFER TO NOTE 6 IN MODE OF OPERATION SECTION OF THE SSA IOM
 ****REFER TO VOLTAGE DIPS AND INTERRUPTIONS SECTION FOR MODE OF OPERATION OF THE SSA IOM

Table 14 SmartStart Assist Troubleshooting

SmartStart Assist Flashing Sequence

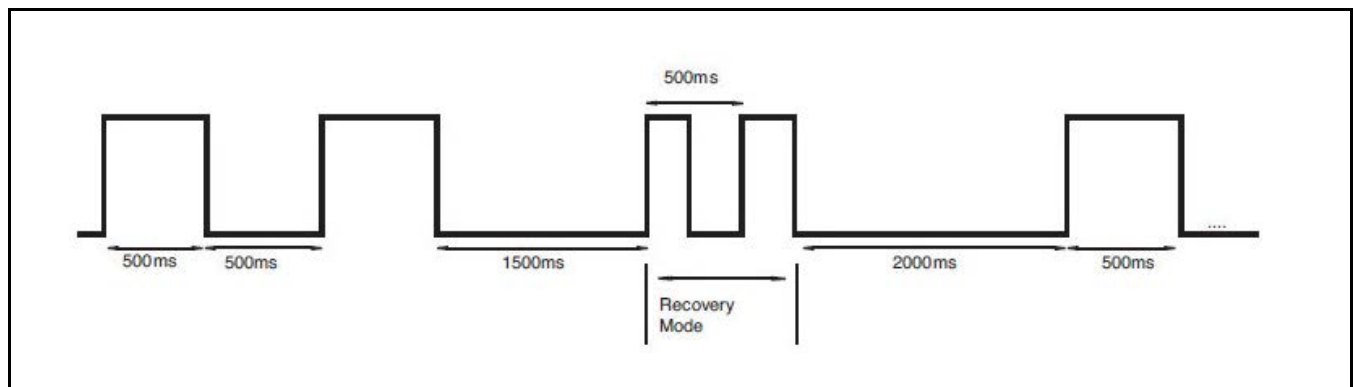

Fig. 14 SmartStart Assist Flashing Sequence



During recovery from an alarm condition, the red LED will flash at twice the normal flashing frequency between successive flashing cycles as shown above to indicate that the SmartStart Assist is in recovery mode, which lasts for five minutes.

UPM LED Status Indicator (Blink Code) Information

The LED status indicator is found on the UPM board. See Fig. 6 on page #16.

Indication Color	Blinks	Description
GREEN	Solid	18–30 VAC power is present
RED	1	High-pressure lockout
RED	2	Low-pressure lockout
RED	3	Freeze sensor lockout
RED	4	Condensate overflow
RED	5	Brownout
RED	6	Evaporator Freeze condition

Table 15 UPM LED Status Indications

Compressor Ohms

Model	Start Winding	Run Winding
SM024	1.64	1.30
SM036	1.52	0.88
SM048	1.86	0.52
SM060	1.63	0.39
Tolerance +/- 7%. All resistance values must be measured with compressor at room temperature.		

Table 16 Compressor Ohms

OPERATING TEMPERATURES AND PRESSURES

Operating Temperatures and Pressures										
			Cooling				Heating			
Model	Entering Water Temp. F	Water Flow	Suction Pressure PSIG	Discharge Pressure PSIG	Water Temp. Rise °F	Air Temp. Drop °F	Suction Pressure PSIG	Discharge Pressure PSIG	Water Temp. Drop	Air Temp. Rise °F
SM024 PART LOAD	30°	4					71-91	264-322	5-6	15-17
		8					79-96	270-331	3-4	16-18
	40°	4					88-107	277-339	6-7	17-20
		8	115-140	175-214	8-9	19-23	92-112	284-348	4-5	18-21
	50°	4	129-157	218-267	14-17	18-20	98-122	291-356	7-8	20-23
		8	124-151	204-250	8-9	19-22	110-130	298-364	5-6	21-24
	60°	4	134-163	294-305	13-16	17-20	112-136	304-372	8-10	22-26
		8	128-156	233-287	8-9	18-21	117-143	312-381	6-7	23-28
	70°	4	138-168	281-341	13-16	17-19	124-152	318-389	9-11	24-29
		8	133-161	263-323	7-9	18-21	131-159	325-398	6-8	26-31
	80°	4	143-174	317-388	13-16	16-19	136-166	331-405	11-13	27-32
		8	137-167	297-366	7-9	17-20	143-174	339-415	7-9	28-33
	90°	4	147-179	357-437	13-16	16-18				
		8	141-172	335-411	7-9	17-20				
	100°	4	151-185	402-492	13-15	15-18				
		8	146-177	378-459	7-9	16-19				
SM024 FULL LOAD	30°	4					76-92	242-297	3-4	13-14
		8					80-97	249-304	2-3	13-15
	40°	4	125-151	180-221	14-18	19-22	89-108	255-312	4-5	15-17
		8	120-146	169-207	8-10	20-23	93-113	261-320	3-3	16-18
	50°	4	134-163	221-258	14-18	18-21	106-118	267-327	5-6	17-19
		8	129-157	198-242	8-10	19-23	110-126	274-335	3-4	18-21
	60°	4	139-169	241-295	14-17	18-21	113-138	280-342	6-7	19-22
		8	134-163	227-278	8-10	19-22	119-145	287-351	4-5	20-23
	70°	4	144-175	272-333	14-17	17-20	126-155	292-358	7-8	21-24
		8	138-168	255-313	8-10	18-21	133-162	300-367	5-6	22-26
	80°	4	148-181	307-375	14-17	17-19	138-168	305-373	8-9	23-27
		8	143-174	288-353	8-10	18-21	145-177	312-382	5-6	24-29
	90°	4	153-186	346-423	14-17	16-19				
		8	147-179	325-398	8-9	17-20				
	100°	4	158-191	389-477	13-16	16-18				
		8	152-185	366-448	8-9	17-20				

This chart shows approximate temperatures and pressures for a unit in good repair. The values shown are meant as a guide only and should not be used to estimate system charge. This chart assumes rated airflow and 80° d.b./67° w.b. entering air temperature in cooling, 70° d.b. entering air temperature in heating. Heating data at entering fluid temperatures below 50° assumes the use of antifreeze. As a result of continuing research and development, specifications are subject to change without notice.

Table 17 SM024 Operating Temperatures and Pressures

Operating Temperatures and Pressures										
			Cooling				Heating			
Model	Entering Water Temp. F	Water Flow	Suction Pressure PSIG	Discharge Pressure PSIG	Water Temp. Rise °F	Air Temp. Drop °F	Suction Pressure PSIG	Discharge Pressure PSIG	Water Temp. Drop	Air Temp. Rise °F
SM036 PART LOAD	30°	4.5					73-89	266-325	5-6	15-18
		9.0					77-94	272-333	3-4	16-19
	40°	4.5	117-143	189-231	14-17	18-22	86-105	279-341	6-7	17-21
		9.0	112-137	178-217	8-9	19-24	90-110	286-350	4-5	18-22
	50°	4.5	126-154	221-270	14-17	18-21	105-125	293-358	7-8	20-24
		9.0	121-148	207-253	8-9	19-23	109-130	300-366	5-6	21-25
	60°	4.5	131-160	252-308	13-16	17-21	110-134	306-374	8-10	22-27
		9.0	125-153	237-290	8-9	18-22	115-141	314-383	6-7	23-28
	70°	4.5	135-165	284-347	13-16	17-20	122-150	320-391	9-11	24-30
		9.0	130-158	266-326	7-9	18-22	129-157	327-400	6-8	26-32
	80°	4.5	140-171	320-391	13-16	16-20	134-164	333-407	11-13	27-33
		9.0	134-164	300-367	7-9	17-21	141-172	341-417	7-9	28-35
	90°	4.5	144-176	360-440	13-16	16-19	147-179	347-424	12-14	29-36
		9.0	138-169	338-414	7-9	17-21	154-188	355-434	8-10	31-38
100°	4.5	149-182	405-495	13-15	15-19					
	9.0	143-174	381-465	7-9	16-20					
SM036 FULL LOAD	30°	4.5					74-90	244-299	3-4	13-15
		9.0					78-95	251-306	2-3	13-16
	40°	4.5	122-149	183-224	14-18	19-23	87-106	257-314	4-5	15-18
		9.0	117-143	172-210	8-10	20-24	91-111	263-322	3-3	16-19
	50°	4.5	131-160	214-261	14-18	18-22	95-105	269-329	5-6	17-20
		9.0	126-154	201-245	8-10	19-24	100-125	276-337	3-4	18-22
	60°	4.5	136-166	244-298	14-17	18-22	111-136	282-344	6-7	19-23
		9.0	131-160	230-281	8-10	19-23	117-143	289-353	4-5	20-24
	70°	4.5	141-172	275-336	14-17	17-21	124-152	294-360	7-8	21-25
		9.0	135-165	258-313	8-10	18-22	131-160	302-369	5-6	22-27
	80°	4.5	145-178	310-378	14-17	17-20	136-166	307-375	8-9	23-28
		9.0	140-171	291-356	8-10	18-22	143-175	314-384	5-6	24-30
	90°	4.5	150-183	349-426	14-17	16-20				
		9.0	144-176	328-401	8-9	17-21				
100°	4.5	155-189	392-480	13-16	16-19					
	9.0	149-182	369-451	8-9	17-21					

This chart shows approximate temperatures and pressures for a unit in good repair. The values shown are meant as a guide only and should not be used to estimate system charge. This chart assumes rated airflow and 80° d.b./67° w.b. entering air temperature in cooling, 70° d.b. entering air temperature in heating. Heating data at entering fluid temperatures below 50° assumes the use of antifreeze. As a result of continuing research and development, specifications are subject to change without notice.

Table 18 SM036 Operating Temperatures and Pressures

Operating Temperatures and Pressures										
			Cooling				Heating			
Model	Entering Water Temp. F	Water Flow	Suction Pressure PSIG	Discharge Pressure PSIG	Water Temp. Rise °F	Air Temp. Drop °F	Suction Pressure PSIG	Discharge Pressure PSIG	Water Temp. Drop	Air Temp. Rise °F
SM048 PART LOAD	30°	6.0					64-78	248-303	5-6	15-18
		12.0					67-82	254-311	3-4	16-19
	40°	6.0	109-134	183-224	18-22	19-23	75-91	261-319	6-8	17-21
		12.0	105-128	172-210	10-12	20-25	79-96	267-327	4-5	18-23
	50°	6.0	118-144	214-261	18-22	19-23	78-90	273-334	8-10	20-24
		12.0	113-138	201-245	10-12	20-24	82-95	280-342	5-7	21-26
	60°	6.0	122-149	244-298	17-21	18-22	96-117	286-349	9-11	22-27
		12.0	117-143	230-281	10-12	19-24	101-123	293-358	6-8	24-29
	70°	6.0	126-154	275-336	17-21	18-22	107-131	299-365	11-13	25-30
		12.0	121-148	258-316	10-12	19-23	113-138	306-374	7-9	26-32
	80°	6.0	130-159	310-378	17-21	17-21	117-143	311-380	12-15	27-33
		12.0	132-153	291-356	10-12	18-22	123-151	319-390	8-10	29-35
	90°	6.0	134-164	349-426	17-20	17-20				
		12.0	129-158	328-401	9-12	18-22				
	100°	6.0	139-170	392-480	16-20	16-20				
		12.0	133-163	369-451	9-11	17-21				
SM048 FULL LOAD	30°	6.0					71-87	277-339	6-7	15-19
		12.0					75-92	284-347	4-5	16-20
	40°	6.0	118-144	194-237	21-25	19-23	84-102	291-356	7-9	18-22
		12.0	113-138	182-223	12-14	20-24	88-108	299-365	5-6	19-23
	50°	6.0	127-155	226-276	21-25	18-22	92-110	305-373	9-11	20-25
		12.0	122-149	213-260	12-14	19-24	98-120	313-383	6-7	21-26
	60°	6.0	131-160	259-316	21-25	18-22	108-132	320-391	10-13	23-28
		12.0	126-154	243-297	12-14	19-23	113-138	328-400	7-9	24-29
	70°	6.0	136-166	291-355	20-25	17-21	120-147	334-408	12-15	25-31
		12.0	130-159	273-334	12-14	18-22	126-154	342-418	8-10	27-31
	80°	6.0	140-171	328-401	20-24	17-20	131-161	348-425	14-17	27-34
		12.0	135-165	308-377	11-14	18-22	138-169	356-436	9-11	29-36
	90°	6.0	145-177	369-451	20-24	16-20				
		12.0	139-170	347-424	11-14	17-21				
	100°	6.0	149-183	415-508	19-24	16-19				
		12.0	143-175	391-477	11-14	17-21				

This chart shows approximate temperatures and pressures for a unit in good repair. The values shown are meant as a guide only and should not be used to estimate system charge. This chart assumes rated airflow and 80° d.b./67° w.b. entering air temperature in cooling, 70° d.b. entering air temperature in heating. Heating data at entering fluid temperatures below 50° assumes the use of antifreeze. As a result of continuing research and development, specifications are subject to change without notice.

Table 19 SM048 Operating Temperatures and Pressures

Operating Temperatures and Pressures										
			Cooling				Heating			
Model	Entering Water Temp. F	Water Flow	Suction Pressure PSIG	Discharge Pressure PSIG	Water Temp. Rise °F	Air Temp. Drop °F	Suction Pressure PSIG	Discharge Pressure PSIG	Water Temp. Drop	Air Temp. Rise °F
SM060 PART LOAD	30°	7.0					68-84	256-313	5-7	19-23
		14.0					73-89	261-319	4-5	20-25
	40°	7.0	113-138	172-210	18-22	19-23	81-99	277-339	7-8	22-26
		14.0	110-134	161-196	12-14	20-24	86-105	283-346	5-6	23-28
	50°	7.0	116-142	206-252	17-21	19-23	93-114	299-365	8-9	24-29
		14.0	112-137	193-236	12-14	19-24	99-121	305-373	6-7	25-31
	60°	7.0	118-145	241-294	17-21	18-23	106-129	321-392	9-11	26-32
		14.0	115-140	225-275	11-14	19-23	113-138	327-400	7-8	28-34
	70°	7.0	121-148	275-336	17-21	18-22	118-145	342-418	10-12	29-35
		14.0	117-143	257-314	11-14	19-23	126-154	349-427	8-9	30-37
	80°	7.0	123-151	309-378	16-20	18-22	131-160	364-444	11-14	31-38
		14.0	120-146	289-353	11-13	19-23	139-170	371-454	8-10	33-40
	90°	7.0	132-161	348-426	13-16	18-22				
		14.0	128-156	326-398	10-12	19-23				
100°	7.0	128-157	378-462	16-19	17-21					
	14.0	125-152	353-432	11-13	18-22					
SM060 FULL LOAD	30°	7.0					68-84	256-313	5-7	19-23
		14.0					73-89	261-319	4-5	20-25
	40°	7.0	117-143	182-222	15-19	21-26	81-99	277-339	7-8	22-26
		14.0	114-139	170-208	11-14	22-27	86-105	283-346	5-6	23-28
	50°	7.0	120-147	215-263	15-18	20-25	93-114	299-365	8-9	24-29
		14.0	117-143	201-246	11-14	21-26	99-121	305-373	6-7	25-31
	60°	7.0	123-150	248-304	14-17	20-24	106-129	321-392	9-11	26-32
		14.0	119-146	232-284	11-13	21-25	113-138	327-400	7-8	28-34
	70°	7.0	126-154	282-344	14-17	19-24	118-145	342-418	10-12	29-35
		14.0	122-149	263-322	10-13	20-25	126-154	349-427	8-9	30-37
	80°	7.0	129-157	315-385	13-16	19-23	131-160	364-444	11-14	31-38
		14.0	125-153	294-360	10-12	19-24	139-170	371-454	8-10	33-40
	90°	7.0	132-161	348-426	13-16	18-22				
		14.0	128-156	326-398	10-12	19-23				
100°	7.0	134-164	382-466	12-15	17-21					
	14.0	131-160	357-436	9-11	18-22					

This chart shows approximate temperatures and pressures for a unit in good repair. The values shown are meant as a guide only and should not be used to estimate system charge. This chart assumes rated airflow and 80° d.b./67° w.b. entering air temperature in cooling, 70° d.b. entering air temperature in heating. Heating data at entering fluid temperatures below 50° assumes the use of antifreeze. As a result of continuing research and development, specifications are subject to change without notice.

Table 20 SM060 Operating Temperatures and Pressures

MAINTENANCE



DANGER: ELECTRICAL HAZARD

Before performing service or maintenance operations on the system, turn off the main power to the unit. Electrical shock will cause personal injury or death.

Filter changes or cleanings are required at regular intervals. The time period between filter changes will depend upon type of environment in which the equipment is used. In a single-family home, that is not under construction, changing or cleaning the filter every 60 days is sufficient. In other applications such as motels, where daily vacuuming produces a large amount of lint, filter changes may need to be as frequent as biweekly.

NOTICE: Equipment should never be used during construction due to likelihood of wall board dust accumulation in the air coil of the equipment which permanently affects the performance and may shorten the life of the equipment.

An annual “checkup” by a trained and qualified HVAC mechanic is required. Record the performance measurements of volts, amps, and water temperature differences for both heating and cooling. This data should be compared to the information on the unit’s data plate and the data taken at the original startup of the equipment.

Lubrication of the blower motor is not required; however, it may be performed on some motors to extend motor life. Use a **SAE-20** non-detergent electric motor oil.

Check the condensate drain annually by cleaning and flushing to ensure proper drainage.

Periodic lockouts almost always are caused by air or water flow problems. The lockout (shutdown) of the unit is a normal protective measure in the design of the equipment. If continual lockouts occur call a mechanic immediately and have them check for: water flow problems, water temperature problems, airflow problems or air temperature problems. Use of the pressure and temperature charts for the unit may be required to properly determine the cause.

Water Side Pressure Drop in PSIG

Series	GPM	Water PD @ 77°EWT with Water
SM024	3	0.7
	4	1.2
	5	1.7
	6	2.4
	7	3.2
	8	4.0
SM036	6	1.1
	8	1.8
	10	2.7
	12	3.7
	14	4.9
	16	6.2
SM048	6	1.1
	8	1.8
	10	2.7
	12	3.7
	14	4.9
	16	6.2
SM060	7.5	1.1
	10	1.9
	12.5	2.8
	15	3.9
	17.5	5.2
	20	6.6

Table 21 Water Side Pressure Drop in PSIG

DECOMMISSIONING INFORMATION

Only trained and qualified technicians are allowed to decommission and dispose of equipment following the requirements of the Local Authority Having Jurisdiction (AHJ).



WARNING: Decommissioning of this equipment can be hazardous due to system pressure and electrical components. Only trained and qualified personnel can install, repair, service, or disconnect the equipment.

Protecting the Environment



By disposing of this product correctly you will help ensure that the waste undergoes the necessary treatment, recovery, and recycling, thus preventing potentially negative effects on the environment and human health, which could otherwise arise due to inappropriate waste handling.

Components



Many parts in the Heat Pump can be fully recycled at the end of the product life. Contact your city authorities for information about the disposal of recyclable products.

Refrigerant



At the end of the service life of this appliance, and prior to its environmental disposal, a person qualified to work with refrigerant circuits and [AHRI Certified](#)[®] Refrigerant Recovery/Recycling Equipment must recover the refrigerant from within the sealed system.

Hazardous Waste



Some components in the Heat Pump may be considered as hazardous waste, such as batteries. For their disposal contact your local household hazardous waste collection site.

WIRING DIAGRAMS

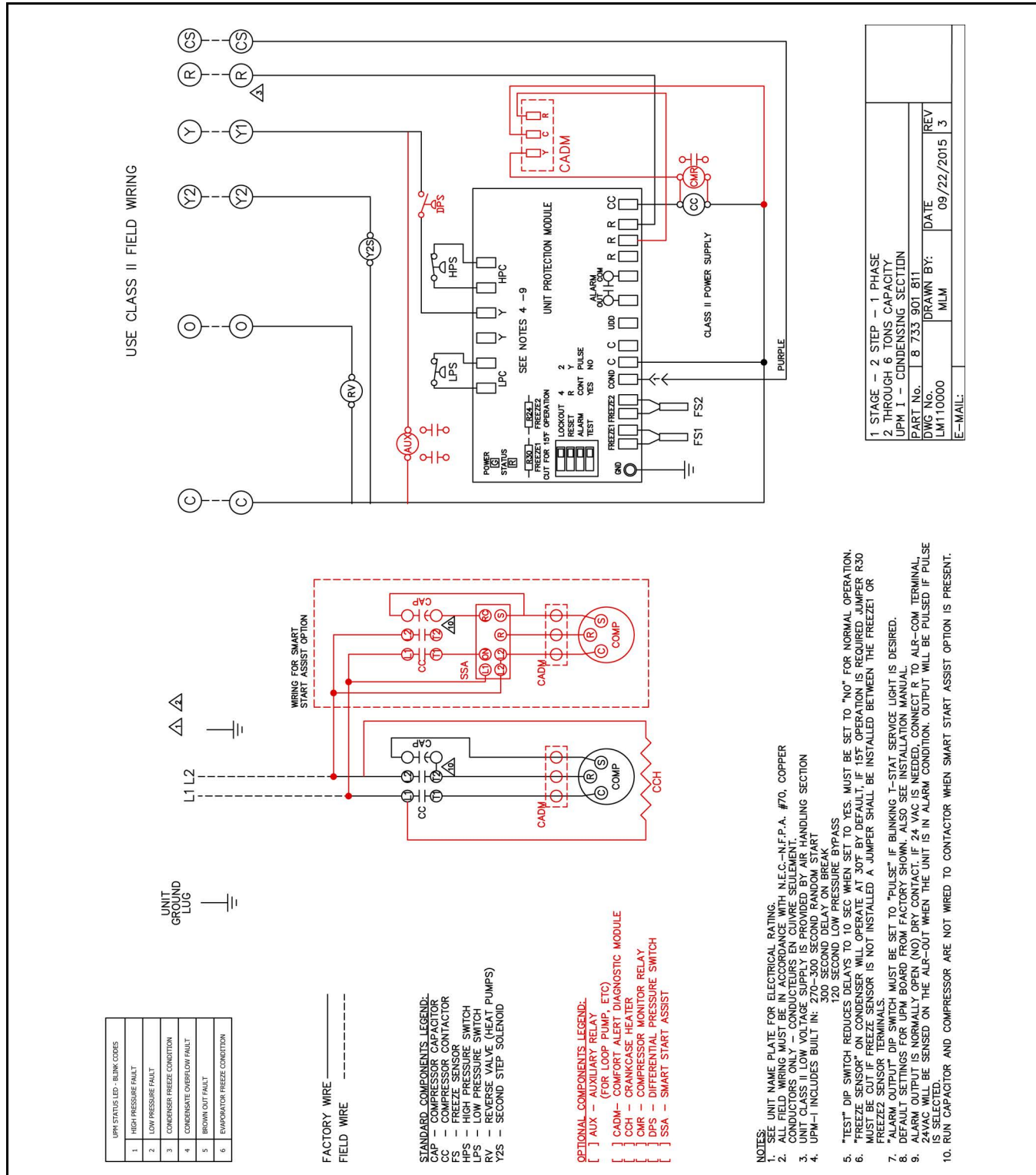

Fig. 15 Wiring Diagrams



FOR REFERENCE ONLY Actual unit wiring may vary from this example. Always refer to the wiring diagram attached to the unit.

SM Split CS + SM Split AH/AV Air Handler Thermostat Wiring Diagram

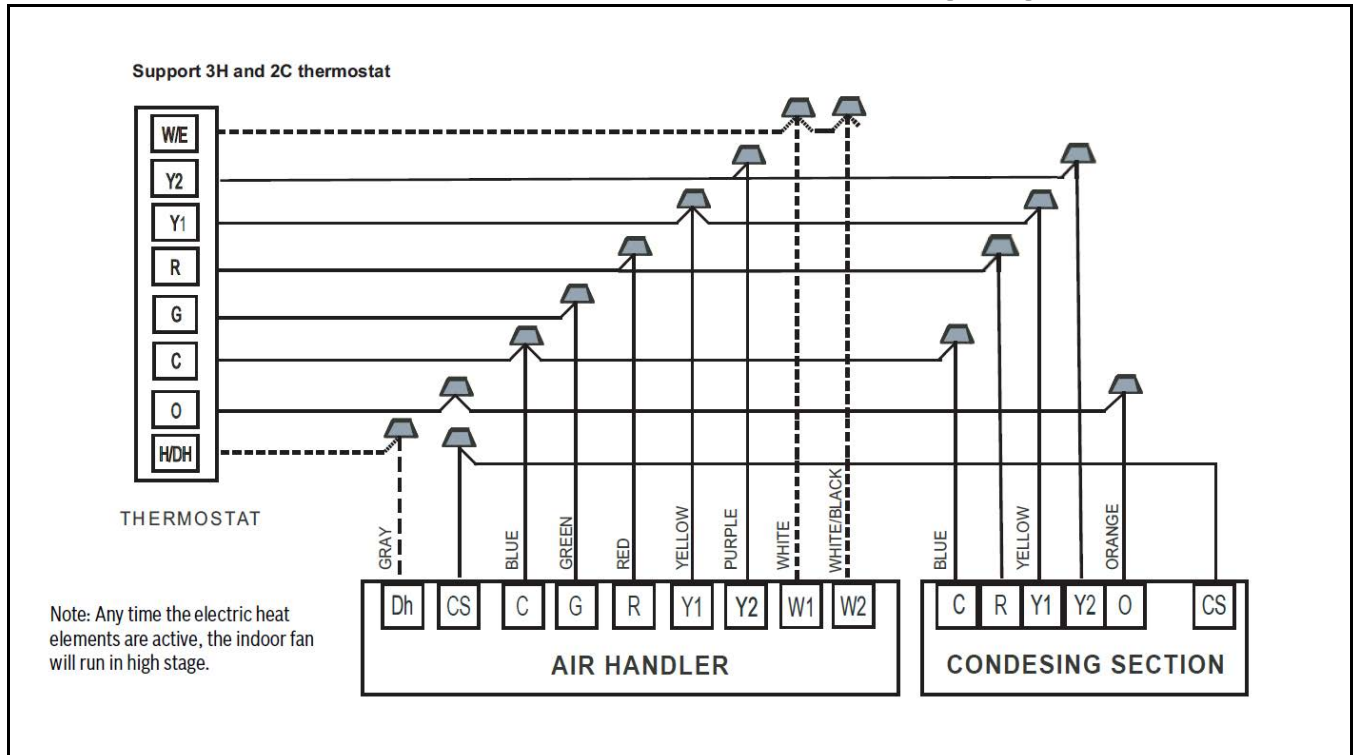

Fig. 16 SM Split CS + SM Split AH/AV Air Handler Thermostat Wiring Diagram

SM Split CS + BVA2.0 Air Handler Thermostat Wiring Diagram

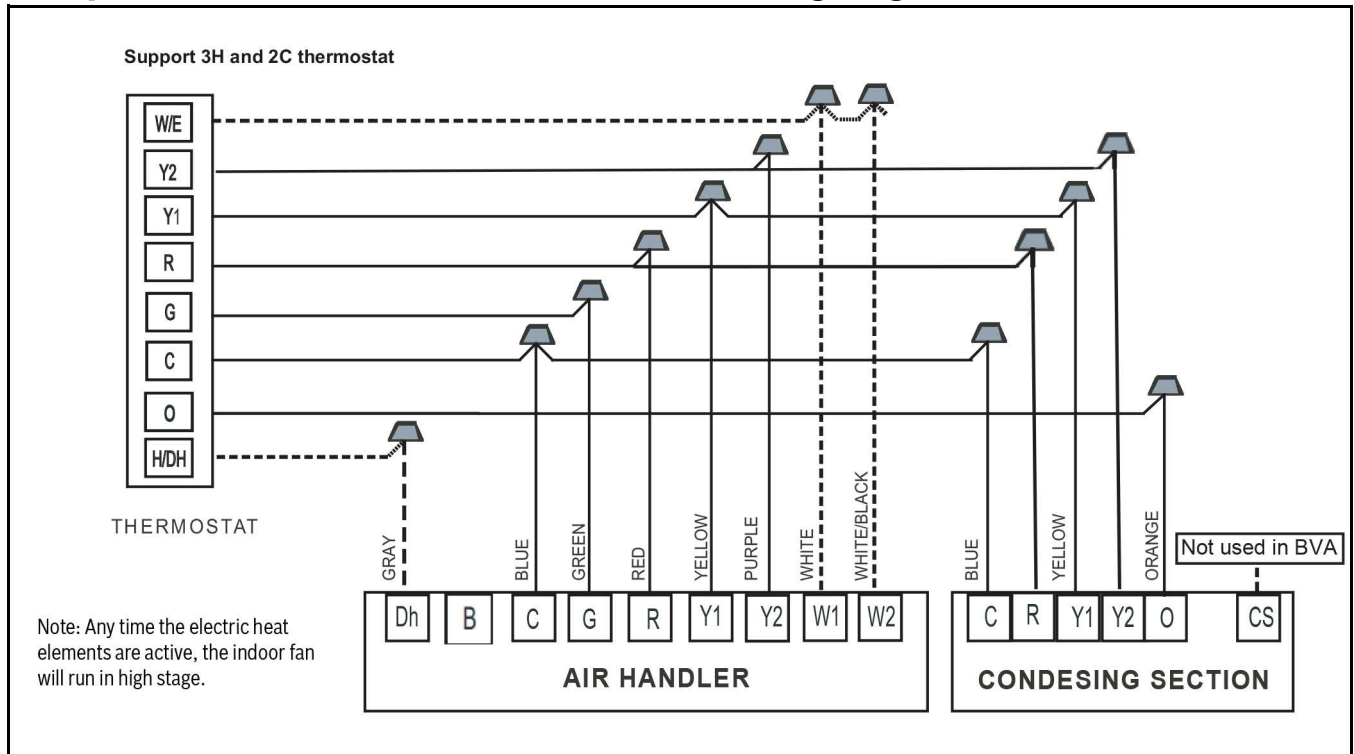
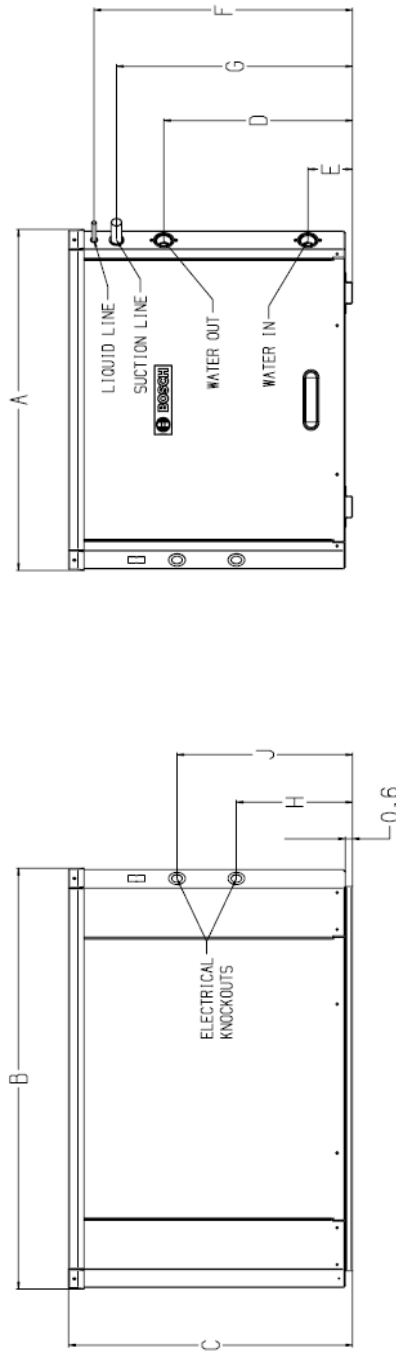

Fig. 17 SM Split CS + BVA2.0 Air Handler Thermostat Wiring Diagram

DIMENSIONAL DRAWINGS

SM Condensing Section

Model	A		C	D	E	F	G	H	J	Water Connections
	Width	Depth								
SM024-CS	24	27.4	21.5	12.7	3.7	3/8" @ 19.4	7/8" @ 17.6	8.6	13.5	3/4" F.P.T
SM036-CS	24	27.4	21.5	15.5	3.5	3/8" @ 19.4	7/8" @ 17.6	8.6	13.5	1" F.P.T
SM048-CS	24	27.4	21.5	15.5	3.5	3/8" @ 19.4	7/8" @ 17.6	8.6	13.5	1" F.P.T
SM060-CS	27	33.4	23.3	15.5	3.7	3/8" @ 21.2	1" @ 19.4	9.5	14.4	1" F.P.T



- NOTES**
- ALL DIMENSIONS WITHIN +/- 0.125"
 - ALL DIMENSIONS ARE IN INCHES
 - SPECIFICATIONS SUBJECT TO CHANGE WITHOUT NOTICE
 - # OPTIONAL HRP FEATURE WITH 1/2" FPT WATER CONNECTION

Fig. 18 Dimensional Drawings



FOR REFERENCE ONLY Actual unit wiring may vary from this example. Always refer to the wiring diagram attached to the unit.

TERMINOLOGY

Acronyms

AHJ – Authority Having Jurisdiction

ECM – Electronically Commutated Motor

EWT – Entering Water Temperature

FLA – Full Load Amps

GLP – Ground Loop Pumping Package

HP – Heat Pump or Horse Power when referring to a motor

HPC – Heat Pump Controller

LED – Light Emitting Diode

LRA – Locked Rotor Amps

NPA – Name Plate Amps

RLA – Running Load Amps

SSA – SmartStart Assist

TXV – Thermal Expansion Valve

UPM – Unit Protection Module

Terms

Conditioned space – Space within a building provided with heated or cooled air or both (or surfaces) and, where required, with humidification or dehumidification means to maintain conditions for an acceptable thermal environment.

Decommissioning – Means the final shut-down and removal from operation or usage of a product or piece of equipment containing fluorinated greenhouse gases.

Discharge Pressure – Referring to the pressure leaving compressor.

Reclamation – Means the reprocessing of a recovered fluorinated greenhouse gas in order to match the equivalent performance of a virgin substance, taking into account its intended use.

Recovery – Referring to the collection and storage of fluorinated-greenhouse gases from products (including containers and equipment) during maintenance or

servicing or prior to the disposal of the products or equipment.

Recycling – Referring to the reuse of a recovered fluorinated-greenhouse gas following a basic cleaning process.

Repair – Referring to the restoration of damaged or leaking products or equipment that contain, or whose functioning relies upon, fluorinated-greenhouse gases, involving a part containing or designed to contain such gases.

Suction Pressure – Referring to the pressure entering compressor.

NOTES

NOTES



BOSCH

Bosch Thermotechnology Corp.

65 Grove Street, Watertown, MA 02472

Phone: +1 (800) 283-3787 | Fax: +1 (603) 965-7568

www.bosch-climate.us.com

Revised 11/2021

8733827905

