



LV Condensing Section



**BOSCH**

**Installation, Operation and Maintenance Manual**

8 733 922 118 (2015/01)

**CONTENTS**

**Condensing Section/Air Handler Pairing ..... 2**

**Key to Symbols..... 3**

**Safety Warnings..... 3**

**General Description..... 4**

**Moving and Storage ..... 4**

**Initial Inspection ..... 4**

**Location..... 4**  
 Condensing Section ..... 4  
 Air Handler ..... 5

**Water Quality ..... 5**

**INSTALLATION ..... 7**  
 Condensing Section ..... 7

**Water Piping ..... 7**

**Electrical ..... 7**  
 - High Voltage ..... 8  
 - Low Voltage ..... 8  
 Cooling and Heating Modes ..... 9  
 Unit Protection Module Safety Features ..... 9

**Options..... 14**  
 Unit Mounted Non-Fused Disconnect Switch..... 14  
 Internal 2-Way Water Valve ..... 14  
 Automatic Flow Control Valve ..... 14  
 LED Annunciator..... 14  
 Flow Proving Switch..... 14

**Application Considerations ..... 14**  
 Well Water Systems ..... 14  
 Cooling Tower/Boiler Systems ..... 15  
 Geothermal Systems ..... 17

**System Checkout ..... 18**

**Unit Start-up ..... 18**

**Maintenance ..... 18**

**Unit Check-Out Sheet ..... 20**  
 Customer Data ..... 20  
 Unit Nameplate Data ..... 20  
 Operating Conditions ..... 20  
 Auxiliary Heat ..... 21

**Troubleshooting ..... 22**

**Operating Temperatures and Pressures ..... 27**

**Compressor Characteristics ..... 31**

**Wiring Diagrams..... 32**

**Dimensional Drawings ..... 34**

**Notes..... 35**

**CONDENSING SECTION/AIR HANDLER PAIRING**

UNIT MODEL	Paired Air Handler	
	Unit 1	Unit 2
LV018-1CSC	LV018-1AVX	LV018-1AHX
LV018-2CSC	LV018-2AVX	LV018-2AHX
LV024-1CSC	LV024-1AVX	LV024-1AHX
LV024-2CSC	LV024-2AVX	LV024-2AHX
LV024-3CSC	LV024-1AVX	LV024-1AHX
LV024-4CSC	LV024-4AVX	LV024-4AHX
LV030-1CSC	LV030-1AVX	LV030-1AHX
LV030-2CSC	LV030-2AVX	LV030-2AHX
LV030-3CSC	LV030-1AVX	LV030-1AHX
LV030-4CSC	LV030-4AVX	LV030-4AHX
LV036-1CSC	LV036-1AVX	LV036-1AHX
LV036-2CSC	LV036-2AVX	LV036-2AHX
LV036-3CSC	LV036-1AVX	LV036-1AHX
LV036-4CSC	LV036-4AVX	LV036-4AHX
LV042-1CSC	LV042-1AVX	LV042-1AHX
LV042-3CSC	LV042-1AVX	LV042-1AHX
LV042-4CSC	LV042-4AVX	LV042-4AHX
LV048-1CSC	LV048-1AVX	LV048-1AHX
LV048-3CSC	LV048-1AVX	LV048-1AHX
LV048-4CSC	LV048-4AVX	LV048-4AHX
LV060-1CSC	LV060-1AVX	LV060-1AHX
LV060-3CSC	LV060-1AVX	LV060-1AHX
LV060-4CSC	LV060-4AVX	LV060-4AHX
LV070-1CSC	LV070-1AVX	LV070-1AHX
LV070-3CSC	LV070-1AVX	LV070-1AHX
LV070-4CSC	LV070-4AVX	LV070-4AHX

### LV CS MODEL NOMENCLATURE

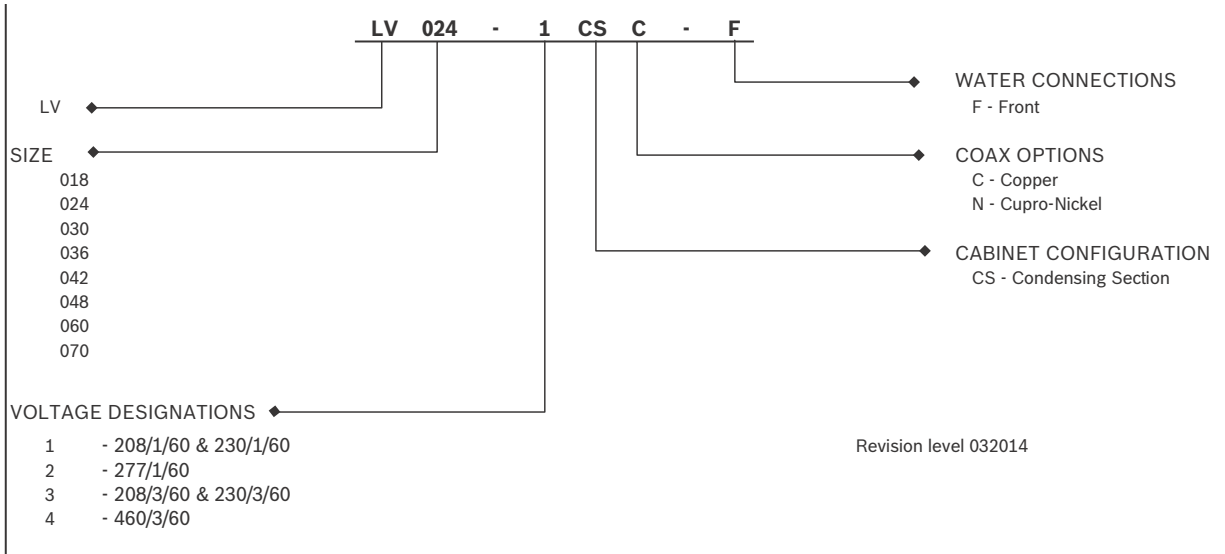

### KEY TO SYMBOLS

#### Warnings



Warnings in this document are identified by a warning triangle printed against a grey background. Keywords at the start of the warning indicate the type and seriousness of the ensuing risk if measures to prevent the risk are not taken.

The following keywords are defined and can be used in this document:

- **NOTE** indicates a situation that could result in damage to property or equipment.
- **CAUTION** indicates a situation that could result in minor to medium injury.
- **WARNING** indicates a situation that could result in severe injury or death.
- **DANGER** indicates a situation that will result in severe injury or death.

#### Important Information



This symbol indicates important information where there is no risk to property or people.

### SAFETY WARNINGS



Installation and servicing of this equipment can be hazardous due to system pressure and electrical components. Only trained and qualified personnel should install, repair, or service the equipment.



Before performing service or maintenance operations on the system, turn off main power to the unit. **Electrical shock could cause personal injury or death.**



When working on equipment, always observe precautions described in the literature, tags, and labels attached to the unit. Follow all safety codes. Wear safety glasses and work gloves. Use a quenching cloth for brazing, and place a fire extinguisher close to the work area.



To avoid the release of refrigerant into the atmosphere, the refrigerant circuit of this unit must be serviced only by technicians who meet local, state, and federal proficiency requirements.



All refrigerant discharged from this unit must be recovered **WITHOUT EXCEPTION**. Technicians must follow industry accepted guidelines and all local, state, and federal statutes for the recovery and disposal of refrigerants. If a compressor is removed from this unit, refrigerant circuit oil will remain in the compressor. To avoid leakage of compressor oil, refrigerant lines of the compressor must be sealed after it is removed.



R410A is **flammable** when exposed to open flame. Recover all refrigerant prior to brazing.

## GENERAL DESCRIPTION

The LV Split water-to-air heat pump provides an unmatched combination of performance, features and flexibility for both high performance new construction applications and replacement of existing water-to-air heat pumps. All units are certified by the Air conditioning, Heating and Refrigeration Institute (AHRI) to AHRI/ANSI/ASHRAE/ISO standard 13256-1 for water-to-air and brine-to-air heat pumps at both Water Loop Heat Pump and Ground Loop Heat Pump application points.

These units are safety listed with Intertek Test Labs (ETL) to cUL standard 1995 and certified to CAN/CSA C22.1 No 236. These units meet all current applicable requirements of ASHRAE 90.1.

Split system heat pumps consist of two independently installed sections allowing for centralized air distribution while remotely locating the section containing the compressor and water-to-refrigerant heat exchanger.

In the cooling mode, the air coil in the air handler section serves as an evaporator and the water-to-refrigerant heat exchanger serves as a condenser. In the heating mode, their roles are reversed.

In cooling mode, the refrigerant lines connecting the two sections consist of one line carrying liquid refrigerant and another carrying refrigerant vapor. The liquid carrying line will be referred to as the liquid line while the vapor carrying line will be referred to as the suction line.

These units are designed and rated for indoor installation only. LV cabinets are constructed of heavy gauge G-90 galvanized steel and will resist most common types of corrosion for the life of the equipment.

The Water-to-Air Heat Pumps are designed to operate with entering fluid temperature between 20°F to 80°F in the heating mode and between 50°F to 110°F in the cooling mode.



For well water applications, a 50°F Minimum Entering Water Temperature (EWT) is recommended with sufficient water flow to prevent the water coil from freezing. Antifreeze solution is required for all closed loop applications.



Cooling Tower/Boiler and Geothermal applications without antifreeze must have means to protect against extreme conditions and equipment failure. Frozen water coils are not covered under warranty. Other equivalent methods of temperature control are acceptable.

### Several factory installed options are available:

Flow Proving Switch, Auxiliary Pump Relay, Zone Valve, Measure Flow, Compressor Monitor Relay, Phase Monitor, Boilerless Control, Disconnect Switch and Status LED. See Options section for more detail.

Safety devices are built into each unit to provide the maximum system protection possible when properly installed and maintained.

## MOVING AND STORAGE

If the equipment is not needed for immediate installation upon its arrival at the job site, it should be left in its packaging and stored in a clean, dry area. Units must only be stored or moved in the normal upright position.

## INITIAL INSPECTION

Be certain to inspect all packaging for each unit as received at the job site before signing the freight bill. Verify that all items have been received and that there are no visible damages; note any shortages or damages on all copies of the freight bill. In the event of damage or shortage, remember that the purchaser is responsible for filing the necessary claims with the carrier. Concealed damages not discovered until after removing the units from the packaging must be reported to the carrier within 24 hours of receipt.

## LOCATION

To maximize system performance, efficiency and reliability, and to minimize installation costs, it is always best to keep the refrigerant lines as short as possible. Every effort should be made to locate the air handler and the condensing section as close as possible to each other.

## Condensing Section

The condensing section is designed for indoor use. Locate the condensing section in an area that provides sufficient room to make water and electrical connections, and allows easy removal of the access panels, for service personnel to perform maintenance or repair.

## Air Handler

Locate the air handler unit in an indoor area that allows easy removal of the filter and access panels, and has enough room for service personnel to perform maintenance or repair. Provide sufficient room to make electrical and duct connections. If the unit is located in a confined space such as a closet, provisions must be made for return air to freely enter that space.



Reference the Factory Manual for your Air Handler, or the BOSCH Air Handler section of this manual for detailed installation and operation.

## WATER QUALITY



Failure to insure proper water quality and flow rates can shorten the life of the heat pump and potentially void the unit warranty.

Maintaining proper water quality is important for insuring a long and trouble free service life for a heat pump.

For closed loop and boiler/tower systems water chemistry can be checked and easily maintained to insure that corrosive elements, dissolved oxygen and pH levels are kept in check. It is important to insure that any additive, antifreeze or corrosion inhibitor that is added to the water loop is compliant with all applicable laws and regulations and is compatible with copper, brass and bronze alloys. Insure that all recommended safety precautions are followed when handling or adding chemicals to the water loop.

For open loop systems, water quality is very important. Table #1 shows acceptable ranges for a variety of water quality factors. The three main concerns in open loop installations are scaling, corrosion and fouling.

In installations with hard water, scaling due to a buildup of carbonates on the heat exchanger wall can gradually degrade the heat pump performance over time. Heat pumps that are affected by scaling may exhibit low suction pressures in heating and high head pressures in cooling with a gradual loss of capacity and efficiency. Scaled heat exchangers can be cleaned by a qualified technician but care should be taken to avoid scaling in the first place.

To limit scaling, water flow rates should be kept at 3 gallons/minute per nominal cooling ton (a 10°F temperature rise in cooling) and care should be taken to avoid air in the water lines from suction side leaks. Cupro-nickel coils are generally recommended.

In installations with high hydrogen sulfide, chlorine or ammonia, corrosion is a potential problem. In these installations a cupro-nickel heat exchanger is recommended along with maintaining proper flow and keeping air out of the system. If water quality is outside of the values in Table #1, then a closed loop is recommended.

Fouling due to iron bacteria can also pose problems in some open loop installations. Iron bacteria fouling can quickly degrade system performance and plug heat exchangers.



Air in the water system will greatly accelerate the fouling or corrosion process.

Table 1: Water Quality

POTENTIAL PROBLEM	Water Characteristic	Acceptable Value	
		Copper	Cupro-Nickel
<b>SCALING</b>	pH (Acidity/Alkalinity)	7-9	7-9
	Hardness (CaCO <sub>3</sub> , MgCO <sub>3</sub> )	< 350 ppm	< 350 ppm
	Ryznar Stability Index	6.0 - 7.5	6.0 - 7.5
	Langelier Saturation Index	-0.5 - +0.5	-0.5 - +0.5
<b>CORROSION</b>	Hydrogen Sulfide (H <sub>2</sub> S)	< 0.5 ppm *	10-50 ppm
	Sulfates	< 125 ppm	< 125 ppm
	Chlorine	< 0.5 ppm	< 0.5 ppm
	Chlorides	< 20 ppm	< 150 ppm
	Carbon Dioxide	< 50 ppm	< 50 ppm
	Ammonia	< 2 ppm	< 2 ppm
	Ammonia Chloride	< 0.5 ppm	< 0.5 ppm
	Ammonia Nitrate	< 0.5 ppm	< 0.5 ppm
	Ammonia Hydroxide	< 0.5 ppm	< 0.5 ppm
	Ammonia Sulfate	< 0.5 ppm	< 0.5 ppm
	Dissolved Solids	< 1,000 ppm	< 1,500 ppm
<b>IRON FOULING</b>	Iron (Fe <sup>2+</sup> Iron Bacteria Potential)	< 0.2 ppm	< 0.2 ppm
	Iron Oxide	< 1 ppm	< 1 ppm
<b>EROSION</b>	Suspended Solids	< 10 ppm, < 600 μm size **	< 10 ppm, < 600 μm size **
	Maximum Water Velocity	6 ft/sec	6 ft/sec
* No "rotten egg" smell present at < 0.5 ppm H <sub>2</sub> S.			
** Equivalent to 30 mesh strainer			

## INSTALLATION



Loosen compressor mounting bolts.



**NOTE:** The installer should comply with all local codes and regulations which govern the installation of this type of equipment. Local codes and regulations take precedent over any recommendations contained in these instructions. In light of local codes, the equipment should be installed in accordance with the recommendations made by the National Electric Code, and in accordance with the recommendations made by the National Board of Fire Underwriters.

## Condensing Section

The condensing section should be mounted on a vibration absorption pad on a cement slab or similar support to provide a good base and some degree of levelness. The cement pad should not come in contact with the foundation or side of the dwelling because sound may be transmitted into the residence. See Figure #1 below.



**DO NOT** remove the protective caps or plugs from the service valves until the refrigerant lines are run and ready for final connections.

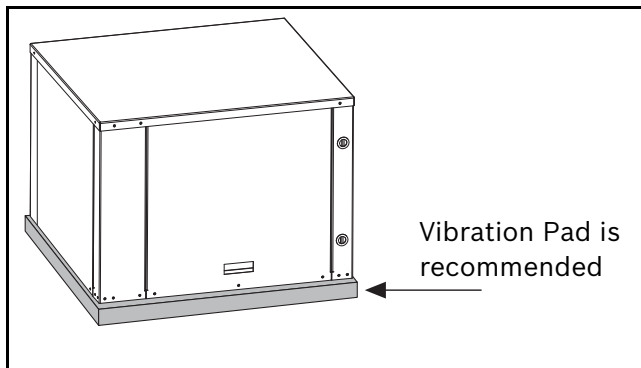

Figure # 1

## WATER PIPING

Supply and return piping must be as large as the unit connections on the heat pump (or larger on long runs in order to reduce pressure drop losses).



Never use flexible hoses of a smaller inside diameter than that of the fluid connections on the unit.

LV units are supplied with either a copper or optional cupro-nickel condenser. Copper is adequate for ground water that is not high in mineral content.



Proper testing is recommended to assure the well water quality is suitable for use with water source equipment.

In conditions anticipating moderate scale formation or in brackish water a cupro-nickel heat exchanger is recommended.



Use cupro-nickel condenser in ground water applications due to possibility of high mineral content and corrosive properties.

Both the supply and discharge water lines will sweat if subjected to low water temperature. These lines should be insulated to prevent damage from condensation. All manual flow valves used in the system must be ball valves. Globe and gate valves must not be used due to high pressure drop and poor throttling characteristics.



Never exceed the recommended water flow rates as serious damage or erosion of the water-to-refrigerant heat exchanger could occur.



Teflon tape sealer should be used when connecting water piping connections to the units to protect against leaks and possible heat exchanger fouling.

Flexible hoses should be used between the unit and the rigid system to avoid possible vibration. Ball valves should be installed in the supply and return lines for unit isolation and unit water flow balancing. Refer to Options section for factory supplied flow control options.

## ELECTRICAL



Always disconnect power to the unit before servicing to prevent injury or death due to electrical shock or contact with moving parts.

## - High Voltage

All field installed wiring must comply with the National Electric Code as well as all applicable local codes. Refer to the unit electrical data on the unit name plate for wire and branch circuit protection sizing. Supply power voltage and phasing should match the required voltage and phasing shown on the unit name plate. Operating the unit below the minimum voltage, above the maximum voltage or with incorrect phasing can result in poor system performance or damage to the heat pump. All field wiring should be installed by qualified and trained personnel. Refer to the unit wiring diagram for field connection requirements.



All power connections must be properly torqued to avoid the risk of overheating.

Power wiring to the heat pump should be enclosed in flexible conduit to minimize the transmission of vibration from the unit cabinet to the building.

For heat pumps with unit mounted disconnect switches, field power should be connected to the marked terminals on the disconnect switch. For heat pumps without unit mounted disconnect switches (except for 460 volt units noted below), power leads are connected to the line (L) side of the compressor contactor. Always be sure to connect the ground lead to the ground lug.

### 460V Wiring Considerations when Pairing Condensing & Air Handler

#### Optional Constant Air Flow Motor

A 460V air handler with the Constant Air Flow Motor option requires a properly sized neutral wire in addition to the three high voltage wires and the ground wire. These units employ a 265 V motor that requires power from one phase of the 460 V supply and the neutral wire.

#### Standard Constant Torque Motor

A 460V air handler with the standard Constant Torque Motor employs a 460 V motor, so in this case the additional neutral wire is not needed. Be sure to plan for the inclusion of a neutral wire if selecting the upgraded constant air flow motor option on a 460V job.

All blower motors are single phase. Compressor motors may be either single or three phase.



The power supply ground wire should never be used as a neutral wire.

## Transformer Settings for 208/230 V Units

As factory built, all 208/230 V units are wired for 230 V operation unless the wire for 208 V option is ordered. For jobsites with a 208 V power supply, the primary leads on the unit transformer will need to be changed from 240 V to 208 V. Refer to the unit wiring diagram for details.

## - Low Voltage

For heat pumps with constant torque fan motors, all thermostat wiring is connected to a terminal block located in the unit electrical box. For heat pumps with a constant air flow fan motor, thermostat wiring is connected to a removable terminal strip located on the ECM motor control board located in the electrical box. Refer to the unit wiring diagram for connection details. The thermostat should be connected to the air handlers and then from the air handler to the condensing section (so they are in series with the thermostat). Note, the low voltage power supply is located in the air handler.



Never route control wiring through the same conduit as power supply wiring.

The heat pump can be controlled by most commonly available single-stage heat pump thermostats. Note that the reversing valve on the unit is energized when the unit is in the cooling mode. Thermostats should be located on an interior wall away from supply ducts. Avoid locations subject to direct sunlight, drafts, or external walls. Thermostat wiring should be 18 AWG. Refer to the installation instructions for the thermostat for further details.



Exceptionally long runs of thermostat wire should be avoided to prevent voltage drops in the control circuit.

The Air Handlers are supplied with a 50 VA control transformer as standard – this transformer supplies the low voltage for both the air handler and condensing section. The VA capacity of the transformer should be considered when connecting low voltage accessories to the heat pump such as thermostats or solenoid valves.

Table #2 shows the VA draw of factory mounted components in the heat pump. The total VA draw of the heat pump internal components plus any attached accessories must be lower than the VA capacity of the unit control transformer.



 Exceeding the transformer capacity can result in low control voltage, erratic unit operation or damage to the heat pump.

**Table 2: Low Voltage VA Draw - Condensing Section**

Standard Construction		Optional Components	
Component	VA	Component	VA
Reversing Valve Solenoid	8-9	Internal 2 Way Motorized Valve	7
Compressor Contactor	6-8	LED Annunciator	1
UPM board	2	Pump/Valve Relay	6-7
<b>Total VA draw</b>	<b>16-19</b>		

**UNITS CONTROLS - UPM**

These heat pumps are designed to be controlled by a standard 1 heat / 1 cool heat pump thermostat. The heat pump control circuit operates on 24 VAC control voltage regardless of the unit supply voltage.

Compressor operation is controlled by the “Y” terminal on the heat pump thermostat terminal block. When “Y” is energized, a signal to start the compressor is sent to the Unit Protection Module (UPM). The UPM checks a number of safety features before then starting the compressor. If any of the safety features connected to the UPM is in a fault condition, the UPM will not start the compressor and will flash a fault code on the red status LED indicating the nature of the fault.

Additionally the UPM will delay compressor operation randomly on initial start up (random start delay) and will prevent the compressor from restarting with less than 5 minutes of off time (anti short cycle delay). Once all faults are cleared and the time delays are satisfied, the UPM will energize the compressor. The compressor will operate as long as the thermostat calls for “Y” and there are no faults. Refer to the troubleshooting chart for fault diagnostics.

**Cooling and Heating Modes**

The unit operates in cooling with the reversing valve energized. When the “O” terminal is energized, the heat pump will be in the cooling mode, however, will not be actively cooling until the “Y” and “G” terminals are also energized. If the “Y” and “G” terminals are energized without the “O” terminal, then the heat pump will operate in the heating mode.

**Unit Protection Module Safety Features**

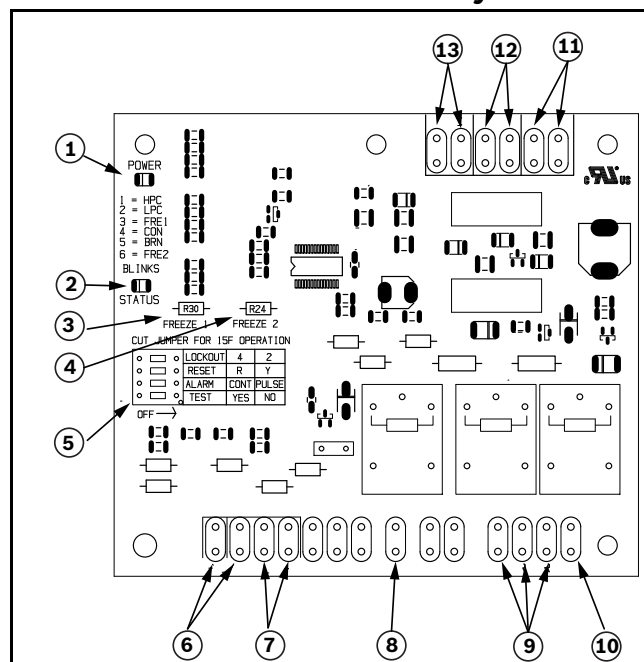

**Figure # 2**

- [1] Board Power Indicator
- [2] UPM Status LED Indicator
- [3] Water Coil Freeze Protection Temperature Selection
- [4] Air Coil Freeze Protection Temperature Selection
- [5] UPM Board Settings
- [6] Water Coil Freeze Connection
- [7] Air Coil Freeze Connection
- [8] LED Unit Display Connection
- [9] 24VAC Power Input
- [10] Compressor Contact Output
- [11] High Pressure Switch Connection
- [12] Call for Compressor Y1
- [13] Low Pressure Switch Connection
- [14] 24VAC Power Common
- [15] Condensate Overflow Sensor
- [16] Dry Contact
- [17] UPM Ground Standoff



If the unit is being connected to a thermostat with a malfunction light, this connection is made at the unit malfunction output or relay.



If the thermostat is provided with a malfunction light powered off of the common (C) side of the transformer, a jumper between “R” and “COM” terminal of “ALR” contacts must be made.



If the thermostat is provided with a malfunction light powered off of the hot (R) side of the transformer, then the thermostat malfunction light connection should be connected directly to the (ALR) contact on the unit’s UPM board.

Safety controls include the following:

- High pressure switch located in the refrigerant discharge line and wired across the HPC terminals on the UPM
- Low pressure switch located in the unit refrigerant suction line and wired across terminals LPC1 and LPC2 on the UPM.



UPM Board Dry Contacts are Normally Open (NO)

- Water side freeze protection sensor, mounted close to condensing water coil, monitors refrigerant temperature between condensing water coil and expansion valve or capillary tube. If temperature drops below or remains at freeze limit trip for 30 seconds, the controller will shut down the compressor and enter into a soft lockout condition. The default freeze limit trip is 26°F, however this can be changed to 15°F by cutting the R30 or Freeze1 resistor located on top of DIP switch SW1.

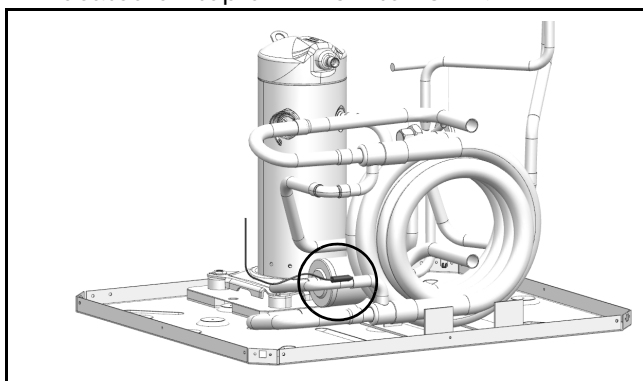

Figure # 3

- Air Coil freeze protection sensor is not factory mounted for split systems, the supplied jumper must be connected across the terminals if no freeze sensor is to be installed in the field. Unit will not operate without a field-installed freeze sensor or jumper.

**UPM DIP SWITCH DEFAULT POSITION**

	lockout	4	2
	reset	R	Y
	alarm	Cont	pulse
	test	yes	no

**UPM Board Factory Default Settings**

<b>TEMP</b>	26°F
<b>LOCKOUT</b>	2
<b>RESET</b>	Y
<b>ALARM</b>	PULSE
<b>TEST</b>	NO

**Table 3: UPM Fault Blink Codes**

LED Blinks	Fault	Fault Criteria
None	None	All fault conditions nominal
1	High Pressure	Refrigerant discharge pressure has exceeded 600 PSIG
2	Low Pressure	Refrigerant suction pressure has fallen below 40 PSIG
3	Water Coil Freeze Condition	Refrigerant temperature to the water coil has fallen below 26°F for 30 seconds
4	Condensate Overflow	Not Applicable
5	Air Coil Freeze Condition	Freeze sensor contact jumper not installed
6	Brown Out	Control voltage has fallen below 18 VAC

**The UPM Board includes the following features:**

- **ANTI-SHORT CYCLE TIMER:** 5 minute delay on break timer to prevent compressor short cycling.
- **RANDOM START:** Each controller has an unique random start delay ranging from 270 to 300 seconds on initial power up to reduce the chance of multiple unit simultaneously starting at the same time after power up or after a power interruption, thus avoiding creating large electrical spike.
- **LOW PRESSURE BYPASS TIMER:** If the compressor is running and the low pressure switch opens, the controller will keep the compressor ON for 120 seconds. After 2 minutes if the low pressure switch remains open, the controllers will shut down the compressor and enter a soft lockout. The compressor will not be energized until the low pressure switch closes and the anti-short cycle time delay expires. If the low pressure switch opens 2-4 times in 1 hour, the unit will enter a hard lockout. In order to exit hard lockout power to the unit would need to be reset.
- **BROWNOUT/SURGE/POWER INTERRUPTION PROTECTION:** The brownout protection in the UPM board will shut does the compressor if the incoming power falls below 18 VAC. The compressor will remain OFF until the voltage is above 18 VAC and ANTI-SHORT CYCLE TIMER (300 seconds) times out. The unit will not go into a hard lockout.
- **MALFUNCTION OUTPUT:** Alarm output is Normally Open (NO) dry contact. If pulse is selected the alarm output will be pulsed. The fault output will depend on the dip switch setting for "ALARM". If it is set to "CONST", a constant signal will be produced to indicate a fault has occurred and the unit requires inspection to determine the type of fault. If it is set to "PULSE", a pulse signal is produced and a fault code is detected by a remote device indicating the fault. See L.E.D Fault Indication below for blink code explanation. The remote device must have a malfunction detection capability when the UPM board is set to "PULSE".



If 24 VAC output is needed R must be wired to ALR-COM terminal; 24 VAC will be available on the ALR-OUT terminal when the unit is in the alarm condition.

- **LED ANNUNCIATOR:** This optional LED kit provides a quick visual indication of whether or not a heat pump is energized or if it has locked out on a fault. The LED kit is mounted to the electrical corner post of the heat pump and employs high intensity LEDs for better visibility. The LED kit will exactly mirror the blink codes on the UPM board (refer to the blink code table in the UPM sequence of operation).
- **TEST DIP SWITCH:** A test dip switch is provided to reduce all time delays settings to 10 seconds during troubleshooting or verification of unit operation.



Operation of unit in test mode can lead to accelerated wear and premature failure of components. The "TEST" switch must be set back to "NO" after troubleshooting/ servicing.

- **FREEZE SENSOR:** The default setting for the freeze limit trip is 26°F (sensor number 1); however this can be changed to 15°F by cutting the R30 resistor located on top of the DIP switch SW1. The UPM controller will constantly monitor the refrigerant temperature with the sensor mounted close to the condensing water coil between the thermal expansion valve and water coil. If temperature drops below or remains at the freeze limit trip for 30 seconds, the controller will shut the compressor down and enter into a soft lockout condition. Both the status LED and the Alarm contact will be active. The LED will flash (three (3) times) the code associated with this alarm condition. If this alarm occurs 2 times (or 4 if Dip switch is set to 4) within an hour the UPM controller will enter into a hard lockout condition.



It is recommended to have a flow switch to prevent the unit from running if water flow is lost.

- **INTELLIGENT RESET:** If a fault condition is initiated, the 5 minute delay on break time period is initiated and the unit will restart after these delays expire. During this period the fault LED will indicate the cause of the fault. If the fault condition still exists or occurs 2 or 4 times (depending on 2 or 4 setting for Lockout dip switch) before 60 minutes, the unit will go into a hard lockout and requires a manual lockout reset.
- **LOCKOUT RESET:** A hard lockout can be reset by turning the unit thermostat off and then back on when the "RESET" dip switch is set to "Y" or by shutting off unit power at the circuit breaker when the "RESET" dip switch is set to "R".

**Table 4: Refrigerant Charge, Line Sizing and Capacity Multiplier<sup>1</sup>**

SYSTEM MODEL	Factory R410A Charge (Oz) <sup>2</sup>	Refrigerant Line O.D. Size (Based on Equivalent Line Length) <sup>3</sup>								Suct. Line Riser Max. <sup>4</sup>
		25 FT. <sup>2</sup>		35 FT.		50 FT.		75 FT		
		LIQ.	SUC.	LIQ.	SUC.	LIQ.	SUC.	LIQ.	SUC.	
LV018	40	3/8	3/4	3/8	3/4	3/8	3/4	3/8	3/4	5/8
LV024	44	3/8	3/4	3/8	3/4	3/8	3/4	3/8	7/8	5/8
LV030	52	3/8	3/4	3/8	3/4	3/8	3/4	3/8	7/8	3/4
LV036	61	3/8	3/4	3/8	3/4	3/8	7/8	3/8	7/8	3/4
LV042	58	3/8	3/4	3/8	3/4	3/8	7/8	1/2	7/8	7/8
LV048	59	3/8	3/4	3/8	7/8	3/8	7/8	1/2	1-1/8	7/8
LV060	93	3/8	7/8	1/2	7/8	1/2	1-1/8	1/2	1-1/8	7/8
LV070	90	3/8	7/8	1/2	1-1/8	1/2	1-1/8	1/2	1-1/8	7/8
CAPACITY MULTIPLIER		1.00		.995		0.990		0.980		

**Example 1:**

Model LV018 with 50ft of equivalent length of 3/8" O.D Liquid Line and factory supplied filter drier. Total system charge = Factory charge +/- adjustment for larger liquid line diameter and additional liquid line length + filter drier adjustment. Total System Charge = 40 oz - (25ft x .6 oz/ft) + (50ft x .60 oz/ft) + 6 oz = 61 oz. Add 21 oz of R410A refrigerant. After adding estimated additional charge, adjust final charge according to subcooling and superheat measurements. See section on charging according to subcooling and superheat.

**Example 2:**

Model LV036 with 45ft of equivalent length of 3/8" O.D Liquid Line and factory supplied filter drier. Estimated Total System Charge = Factory charge +/- liquid line length adjustment + filter drier adjustment. Estimated Total System Charge = 61 oz + ((45ft - 25ft) x .60 oz/ft) + 6 oz = 79 oz. Estimate an additional 18 oz of R410A refrigerant is required. After adding estimated additional charge, adjust final charge according to subcooling and superheat measurements. See section on charging according to subcooling and superheat.

**Example 3:**

Model LV060 with 35ft of equivalent length of 1/2" O.D Liquid Line and factory supplied filter drier. Total system charge = Factory charge - (25ft x 0.6 oz/ft) + (35ft x 1.15 oz/ft) + filter drier adjustment. Total System Charge = 93 oz - 15 + 40 + 9 oz = 127 oz. Add 34 oz of R410A refrigerant. After adding estimated additional charge, adjust final charge according to subcooling and superheat measurements. See section on charging according to subcooling and superheat.

**Notes:**

1. Liquid and suction line sizes should be sized according to table, not according to king valve connection size.
2. Factory Charge is based on 25 ft of lineset with lineset diameter according to table. Charge adjustments will need to be made for linesets of differing length and/or diameters. Additional charge must also be added for factory supplied filter drier. All charge rates MUST ALWAYS to be confirmed and adjusted if necessary by subcooling and superheat measurements (even with a 25 ft lineset and default factory charge). See section on charging according to subcooling and superheat.
3. Next diameter size up should be used if equivalent length is longer than shown (75 ft is max)
4. Suction line max riser diameter is typically sized to meet minimum of 1,250 FPM refrigerant velocity for proper oil return.
5. With 1/2" liquid lines it is recommended to place units as close as practical (minimizing the increased refrigerant volume imposed by the larger line) for maximum compressor life.

**Table 5: Liquid Line Charge Per Linear Foot**

	Liquid line Size, O.D.				
	1/4	5/16	3/8	1/2	5/8
R410A oz per foot	.25	.44	.60	1.15	1.95

**Table 6: Additional Charge for factory supplied Filter Drier**

MODEL	Filter Drier Description	Charge – Filter Drier oz
LV018	Filter Drier, BiFlow, R410A, 8 cu in, 3/8 ODF	6
LV024	Filter Drier, BiFlow, R410A, 8 cu in, 3/8 ODF	6
LV030	Filter Drier, BiFlow, R410A, 8 cu in, 3/8 ODF	6
LV036	Filter Drier, BiFlow, R410A, 8 cu in, 3/8 ODF	6
LV042	Filter Drier, BiFlow, R410A, 8 cu in, 3/8 ODF	6
LV048	Filter Drier, BiFlow, R410A, 16 cu in, 5/8 ODF	9
LV060	Filter Drier, BiFlow, R410A, 16 cu in, 5/8 ODF	9
LV070	Filter Drier, BiFlow, R410A, 16 cu in, 5/8 ODF	9

**Notes:**

1. All units require a bi-flow filter drier. Filter drier must be UL listed for R410A with a maximum working pressure of 680 psi. Substitute driers are permissible assuming drier meets these specifications.
2. Final Charge must be adjusted for filter drier - refer to table for charge adjustment.

**Table 7: Service Valve Connection**

SYSTEM MODEL	Service Valve Connection Sizes	
	LIQ.	SUC.
LV018	3/8	3/4
LV024	3/8	3/4
LV030	3/8	3/4
LV036	3/8	3/4
LV042	3/8	3/4
LV048	3/8	3/4
LV060	3/8	7/8
LV070	3/8	7/8

## OPTIONS

A number of factory installed options are available on Condensing Sections. The following details the purpose, function and components of each option.

### Unit Mounted Non-Fused Disconnect Switch

The heat pumps can be supplied with an optional unit mounted disconnect switch mounted to the electrical corner post of the unit.

Field electrical wiring is connected to the switch and the switch then routes power to the heat pump electrical box. When the switch is in the "OFF" position, the heat pump electrical box is completely de-energized.

### Internal 2-Way Water Valve

In many applications, including variable pumping and well water installations, a motorized water valve is required on the heat pump water circuit. This water valve can be factory mounted and wired internally to the unit.

The internal water valve option features a 24VAC motorized water valve rated to 450 psig working pressure. This valve is wired to open on a thermostat call for compressor operation (heating or cooling) and will remain open as long as the thermostat calls. The valve can remain seated with up to 20 psi of back pressure on all sizes.

The valve consists of two main parts: the valve body and the actuator. The valve body is brazed into the leaving water line of the heat pump and is a permanent part of the unit. The valve actuator can be easily removed from the valve body for service.

Refer to the water side pressure drop table in the operating temperatures and pressures section of this manual to determine the appropriate pressure drop across the heat pump with and without the water valve option.



Note that the 2-Way Water Valve option will add additional pressure drop between the water in and water out connections of the heat pump.

---



Note that this water valve cannot be used as an isolation valve.

---

### Automatic Flow Control Valve

This factory installed option provides controlled flow over a wide range of working pressures and temperatures - limiting the water/fluid flow to the recommended rate (roughly 3 gpm / ton) for optimum system efficiency. The valve prevents excessive flow - protecting the heat exchanger surface from erosion and also minimizing the number of valves needed for unit and building / system balancing. The valve is designed to resist clogging and have a long life without maintenance; however, if maintenance is needed, the valve cartridge can easily be unscrewed and replaced.

### LED Annunciator

This heat pump can be equipped with an optional LED annunciator kit. This LED kit can provide a quick visual indication of whether or not a heat pump is energized and if it has locked out on a fault. The LED kit is mounted to the electrical corner post of the heat pump and employs high intensity LED's for better visibility. The LED kit will exactly mirror the LED blink codes on the UPM board (refer to the blink code table in the UPM sequence of operation).

### Flow Proving Switch

This heat pump can be equipped with an optional flow proving switch. This device senses a pressure drop across the water side of the condenser coil indicating water flow. When the pressure drop rises to five feet of head, the flow proving switch will enable the compressor. If the pressure drop across the condenser does not reach the required value, then the unit compressor is disabled.

## APPLICATION CONSIDERATIONS

### Well Water Systems

Copper is adequate for ground water that is not high in mineral content. Should your well driller express concern regarding the quality of the well water available or should any known hazards exist in your area, we recommend proper testing to assure the well water quality is suitable for use with water source equipment. In conditions anticipating moderate scale formation or in brackish water a cupro-nickel heat exchanger is recommended. In well water applications water pressure must always be maintained in the heat exchanger. This can be accomplished with either a control valve or a bladder type expansion tank.

When using a single water well to supply both domestic water and the heat pump, care must be taken to ensure that the well can provide sufficient flow for both. In well water applications a slow closing solenoid valve must be used to prevent water hammer. Solenoid valves should be connected across Y1 and C1 on the interface board for all. Make sure that the VA draw of the valve does not exceed the contact rating of the thermostat.

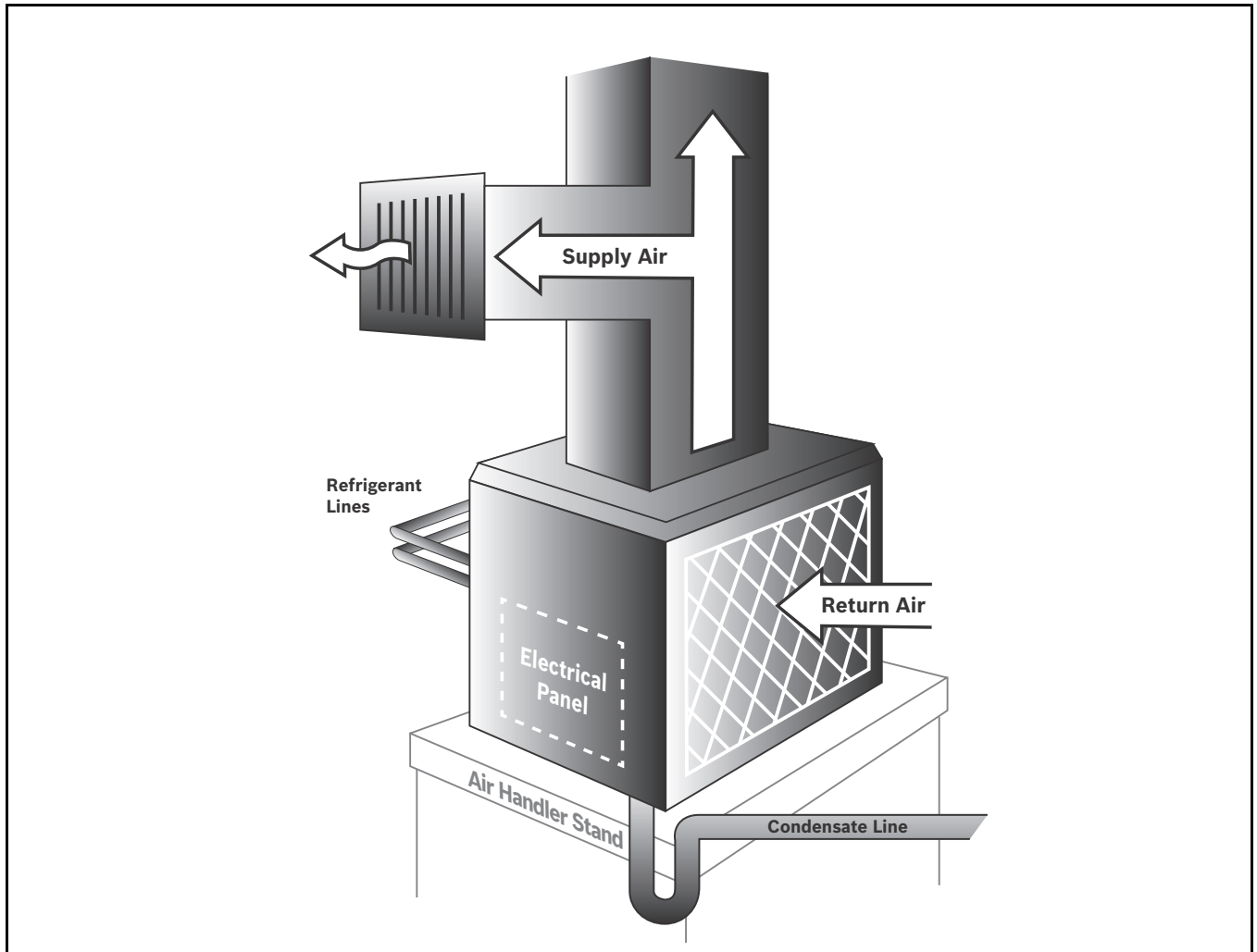

Figure # 4 Example System Set-up

### Cooling Tower/Boiler Systems

The cooling tower and boiler water loop temperature should be maintained between 50° F to 110 ° F to assure adequate cooling and heating performance.

In the cooling mode, heat is rejected from the unit into the water loop. A cooling tower provides evaporative cooling to the loop water thus maintaining a constant supply temperature to the unit. When utilizing open cooling towers, chemical water treatment is mandatory to ensure the water is free from corrosive elements. A secondary heat exchanger (plate frame) between the unit and the open cooling tower may also be used.

It is imperative that all air be eliminated from the closed loop side of the heat exchanger to protect against fouling. In the heating mode, heat is absorbed from the water loop. A boiler can be utilized to maintain the loop at the desired temperature.



Water in piping exposed to extreme low ambient temperatures is subject to freezing.



Consult the specification sheets for piping sizes. Teflon tape sealer should be used when connecting to the unit to protect against leaks and possible heat exchanger fouling.

Do not overtighten the connections. Flexible hoses should be used between the unit and the rigid system to avoid damage from vibration. Ball valves should be installed in the supply and return lines for unit isolation and unit water flow balancing.

Pressure/temperature ports are recommended in both supply and return lines for system flow balancing. Water flow can be accurately set by measuring the water-to-refrigerant heat exchanger's water side pressure drop.



See operating temperatures and pressures for water flow vs. pressure drop information.

No unit should be connected to the supply or return piping until the water system has been completely cleaned and flushed to remove any dirt, piping chips or other foreign material. Supply and return hoses should be connected together during this process to ensure the entire system is properly flushed.

After the cleaning and flushing has taken place the unit may be connected to the water loop and should have all valves wide open. (Figure #5)

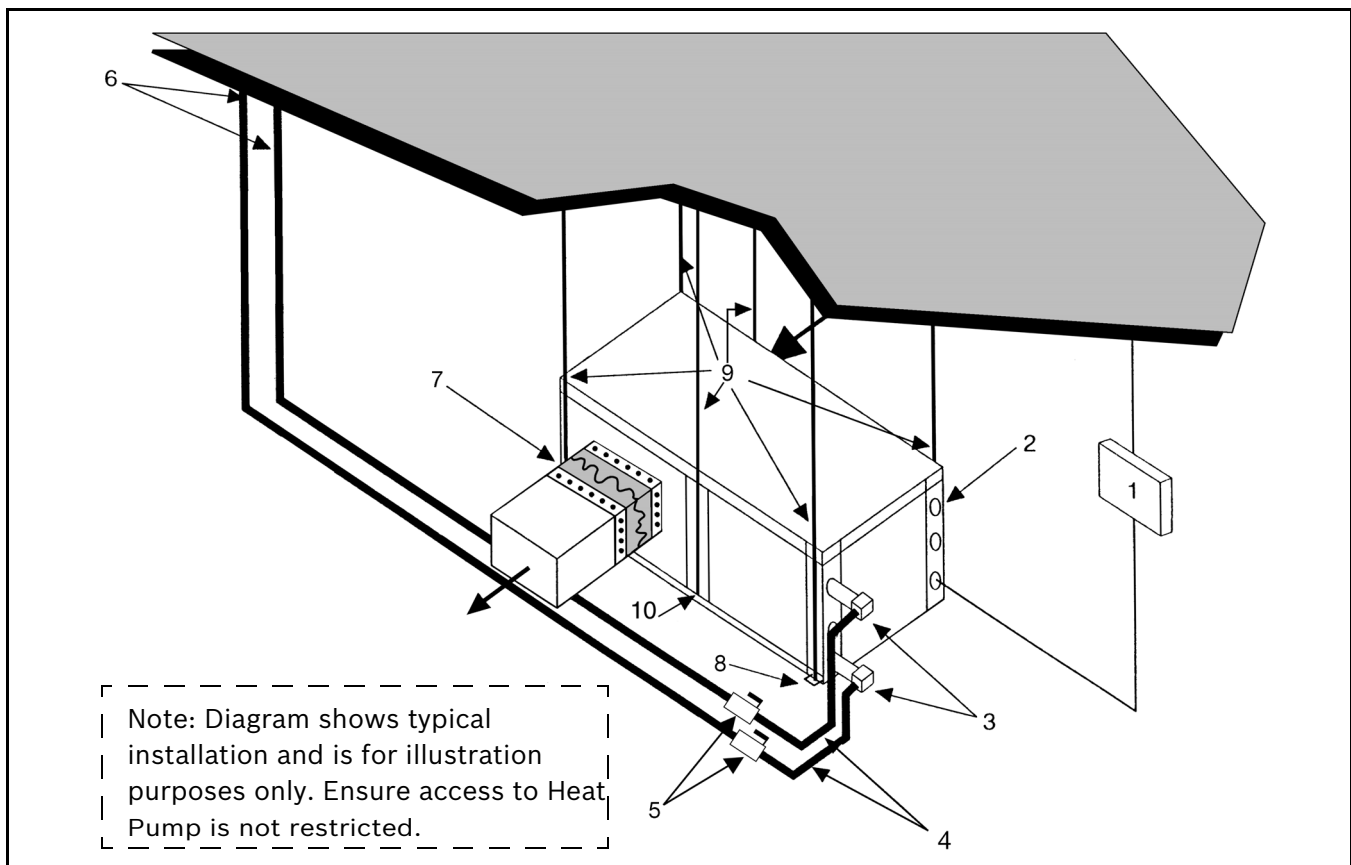

Figure # 5

- |  |                               |
|--|-------------------------------|
| [1] Line voltage disconnect (unit)           | [7] Flex duct connection      |
| [2] Low voltage control connection           | [8] Hanging bracket assembly  |
| [3] P/T ports (optional)                     | [9] Threaded rod              |
| [4] Hose kits (optional)                     | [10] Hanging bracket assembly |
| [5] Ball valves                              |                               |
| [6] Supply and return line of central system |                               |



## Geothermal Systems

Each condensing section comes with an insulated water-to-refrigerant heat exchanger making it suitable for geothermal applications. Closed loop and pond applications require specialized design knowledge. No attempt at these installations should be made unless the dealer has received specialized training. Utilizing the Ground Loop Pumping Package (GLP), makes the

installation easy. Anti-freeze solutions are utilized when low evaporating conditions are expected to occur. Refer to the GLP installation manuals for more specific instructions. (Figure #6)

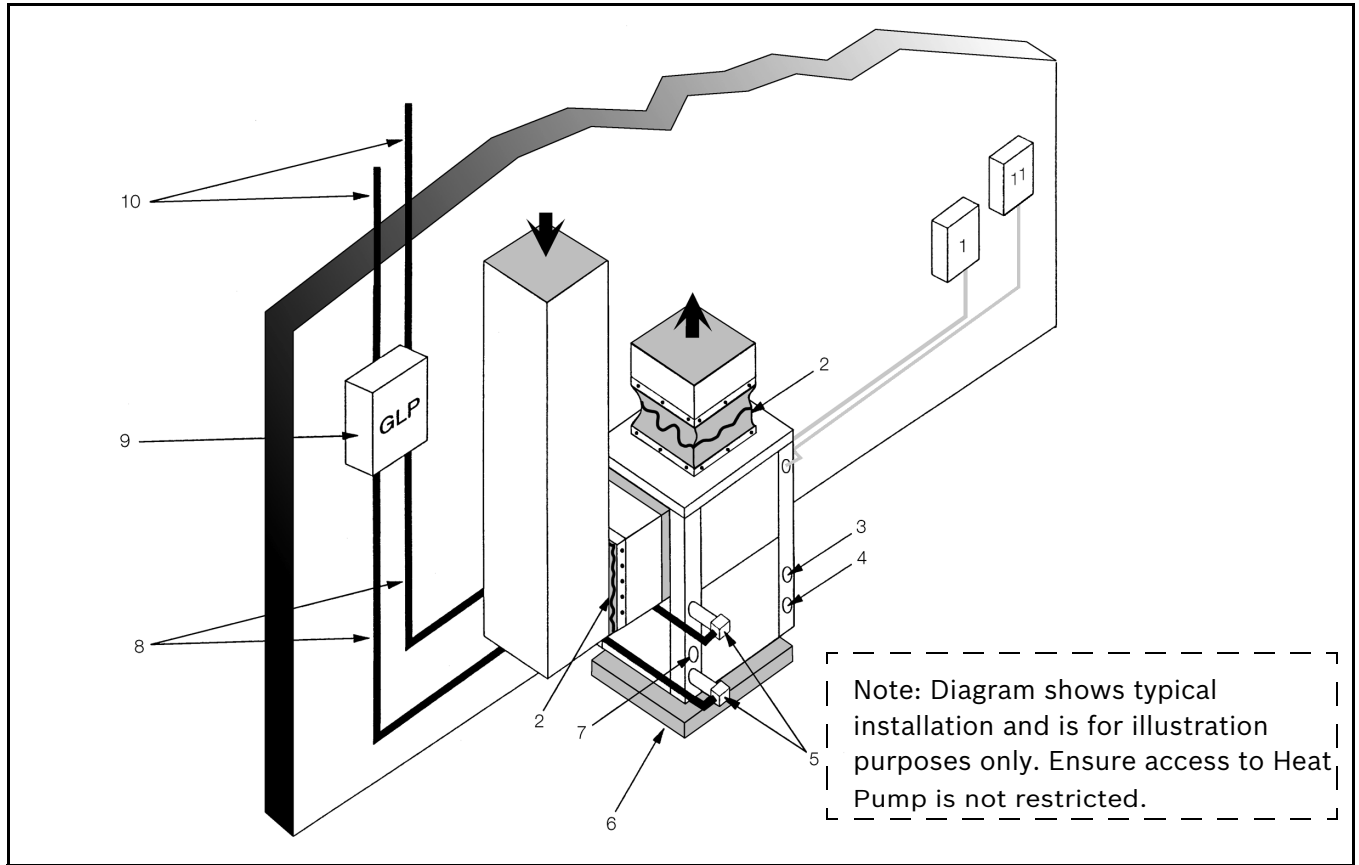

Figure # 6

- [1] Line voltage disconnect (unit)
- [2] Flex duct Connection
- [3] Low voltage control connection
- [4] Line voltage connection (unit)
- [5] P/T ports
- [6] Vibration pad
- [7] Condensate drain connection
- [8] Ground loop connection kit
- [9] Ground loop pumping package
- [10] Polyethylene with insulation
- [11] Line voltage disconnect (electric heater)

## SYSTEM CHECKOUT

After completing the installation, and before energizing the unit, the following system checks should be made:

- Verify that the supply voltage to the heat pump is in accordance with the nameplate ratings.
- Make sure that all electrical connections are tight and secure.
- Check the electrical fusing and wiring for the correct size.



Ensure cabinet and Electrical Box are properly grounded.

- Verify that the low voltage wiring between the thermostat and the unit is correct.
- Verify that the water piping is complete and correct.
- Check that the water flow is correct, and adjust if necessary.
- Check the blower for free rotation, and that it is secured to the shaft.
- Verify that vibration isolation has been provided.
- Unit is serviceable. Be certain that all access panels are secured in place.

### Considerations:

1. Always check incoming line voltage power supply and secondary control voltage for adequacy. Transformer primaries are dual tapped for 208 and 230 volts. Connect the appropriate tap to ensure a minimum of 18 volts secondary control voltage. 24 volts is ideal for best operation.
2. Long length thermostat and control wiring leads may create voltage drop. Increased wire gauge or up-sized transformers may be required to ensure minimum secondary voltage supply.
3. The guidelines for wiring between a thermostat and the unit are: 18 GA up to 60 foot, 16 GA up to 100 ft and 14 GA up to 140 ft.
4. Do not apply additional controlled devices to the control circuit power supply without consulting the factory. Doing so may void equipment warranties.
5. Check with all code authorities on requirements involving condensate disposal/over flow protection criteria.

## UNIT START-UP

1. Put the UPM board in “test” mode.
2. Set the thermostat to the highest setting.
3. Set the thermostat system switch to “COOL”, and the fan switch to the “AUTO” position. The reversing valve solenoid should energize. The compressor and fan should not run.
4. Reduce the thermostat setting approximately 5 degrees below the room temperature.
5. Verify the heat pump is operating in the cooling mode.
6. Turn the thermostat system switch to the “OFF” position. The unit should stop running and the reversing valve should de energize.
7. Leave the unit off for approximately (5) minutes to allow for system equalization.
8. Turn the thermostat to the lowest setting.
9. Set the thermostat switch to “HEAT”.
10. Increase the thermostat setting approximately 5 degrees above the room temperature.
11. Verify the heat pump is operating in the heating mode.
12. Set the thermostat to maintain the desired space temperature.
13. Check for vibrations, leaks, etc.

## MAINTENANCE

1. Filter changes or cleanings are required at regular intervals. The time period between filter changes will depend upon type of environment the equipment is used in. In a single family home, that is not under construction, changing or cleaning the filter every 60 days is sufficient. In other applications such as motels, where daily vacuuming produces a large amount of lint, filter changes may need to be as frequent as biweekly.



Equipment should never be used during construction due to likelihood of wall board dust accumulation in the air coil of the equipment which permanently affects the performance and may shorten the life of the equipment.

2. An annual “checkup” is recommended by a licensed refrigeration mechanic. Recording the performance measurements of volts, amps, and water temperature differences (both heating and cooling) is recommended. This data should be compared to the information on the unit’s data plate and the data taken at the original startup of the equipment.
3. Lubrication of the blower motor is not required, however may be performed on some motors to extend motor life. Use **SAE-20** non-detergent electric motor oil.
4. The condensate drain should be checked annually by cleaning and flushing to ensure proper drainage.
5. Periodic lockouts almost always are caused by air or water flow problems. The lockout (shutdown) of the unit is a normal protective measure in the design of the equipment. If continual lockouts occur call a mechanic immediately and have them check for: water flow problems, water temperature problems, air flow problems or air temperature problems. Use of the pressure and temperature charts for the unit may be required to properly determine the cause.

**Table 8: Water Side Pressure Drop**

MODEL	Water Flow Rate (GPM)	Water Side Pressure Drop with out Internal Valve (PSI)	Water Side Pressure Drop with Internal Valve (PSI)
LV018	2.5	1.1	2.1
	4	2.7	5.2
	5	4.0	8.0
LV024	3	1.7	2.0
	4	2.8	3.4
	6	5.8	7.2
LV030	4	2.0	2.6
	6	4.2	5.6
	8	7.0	9.6
LV036	4.5	1.6	2.4
	6	2.6	4.0
	9	5.4	8.6
LV042	5	2.0	3.0
	8	4.6	7.2
	11	8.2	13.0
LV048	6	0.8	1.4
	8	1.4	2.5
	12	2.8	5.4
LV060	7.5	1.4	2.4
	10	2.3	4.1
	15	4.8	8.8
LV070	9	2.0	3.4
	12	3.4	5.9
	18	7.0	12.7
All values based upon pure water at 70° F.			

### UNIT CHECK-OUT SHEET

#### Customer Data

Customer Name \_\_\_\_\_ Date \_\_\_\_\_  
 Address \_\_\_\_\_  
 Phone \_\_\_\_\_ Unit Number \_\_\_\_\_

#### Unit Nameplate Data

Unit Make \_\_\_\_\_  
 Model Number \_\_\_\_\_ Serial Number \_\_\_\_\_  
 Refrigerant Charge (oz) \_\_\_\_\_  
 Compressor: RLA \_\_\_\_\_ LRA \_\_\_\_\_  
 Blower Motor: FLA (or NPA) \_\_\_\_\_ HP \_\_\_\_\_  
 Maximum Fuse Size (Amps) \_\_\_\_\_  
 Maximum Circuit Ampacity \_\_\_\_\_

#### Operating Conditions

	Cooling Mode	Heating Mode
Entering / Leaving Air Temp	_____ / _____	_____ / _____
Entering Air Measured at:	_____	_____
Leaving Air Measured at:	_____	_____
Entering / Leaving Fluid Temp	_____ / _____	_____ / _____
Fluid Flow (gpm)	_____	_____
Compressor Volts / Amps	_____ / _____	_____ / _____
Blower Motor Volts / Amps	_____ / _____	_____ / _____
Source Fluid Type	_____	_____
Fluid Flow (gpm)*	_____	_____
Fluid Side Pressure Drop*	_____	_____
Suction / Discharge Pressure (psig)*	_____ / _____	_____ / _____
Suction / Discharge Temp*	_____ / _____	_____ / _____
Suction Superheat*	_____	_____

**Customer Data**

Entering TXV / Cap Tube Temp\* \_\_\_\_\_

Liquid Subcooling\* \_\_\_\_\_

\* Required for Troubleshooting ONLY

**Auxiliary Heat**

Unit Make \_\_\_\_\_

Model Number: \_\_\_\_\_

Serial Number \_\_\_\_\_

Max Fuse Size (Amps) \_\_\_\_\_

Volts / Amps \_\_\_\_\_

Entering Air Temperature \_\_\_\_\_

Leaving Air Temperature \_\_\_\_\_

Bosch Group

601 NW 65th Court

Fort Lauderdale, FL 33309

Phone: (866) 642-3198



Scan the QR code and attach picture of this form with the information requested.

**TROUBLESHOOTING**

<b>Table 9: UNIT TROUBLESHOOTING</b>					
<b>Problem</b>	<b>Mode</b>		<b>Check</b>	<b>Possible Cause</b>	<b>Action</b>
	<b>Cooling</b>	<b>Heating</b>			
<b>No compressor operation but fan runs</b>	X		Is fault LED Blinking 1 time?	High Pressure fault - no or low water flow	Check water valves and/or pumps for proper operation. Check for water coil blockage.
				High Pressure fault - high water temperature	Check water temperature - is it in range?
				High Pressure fault - fouled or scaled water coil	Check for proper flow rate and water temperature, but low water side temp rise in cooling
		X		High Pressure fault - no or low air flow	Check fan motor for proper operation.
					Check air filter
					Inspect air coil for dirt/debris
					Check duct work - are dampers closed or blocked?
	X		Is fault LED Blinking 2 times?	Low Pressure fault - no or low air flow	Check fan motor for proper operation.
					Check air filter
					Inspect air coil for dirt/debris
				Low Pressure fault - low refrigerant	Check duct work - are dampers closed or blocked?
					Check refrigerant pressure with gauge set
					Check water valves and/or pumps for proper operation. Check for water coil blockage.
		X		75Unit	Check for proper flow rate and water temperature, but low water side temp drop in heating.
				Low Pressure fault - low refrigerant	Check refrigerant pressure with gauge set
	X	Is fault LED Blinking 3 times?	Freeze fault, water coil - no or low water flow	Check water valves and/or pumps for proper operation. Check for water coil blockage.	
			Freeze fault - low water temperature	Check water temperature - is it below 40° entering? If heat pump is connected to a closed loop with antifreeze check that the "FREEZE 1" resistor on the UPM board has been cut to set the unit to antifreeze mode (see UPM features on pages 15-17).	
			Freeze fault - low refrigerant	Check refrigerant pressure with gauge set	

**Table 9: UNIT TROUBLESHOOTING**

Problem	Mode		Check	Possible Cause	Action
<b>No compressor operation but fan runs</b>	X		Is fault LED Blinking 4 times?	Condensate fault - poor drainage	Check condensate pan for high water level. Check drain line for blockages, double trapping or inadequate trapping.
				Condensate fault - blocked return air	Check condensate pan for high water level. Check air filter and return air duct work for blockage. Check that there is adequate space between the return air opening and walls or other obstructions on free return applications.
	X	X	Is fault LED Blinking 5 times?	Brown out fault - low supply voltage	Check primary voltage - insure it is within the limits listed on the unit data plate.
				Brown out fault - overloaded control circuit	Check control voltage - if it is below 18 V check accessories connected to the unit and insure that they do not exceed the VA draw shown on page 11.
				Brown out fault - bad thermostat connection	Check that thermostat wiring is proper gauge and length, that it is not damaged and that all connections at the thermostat and heat pump are secure.
	X		Is fault LED Blinking 6 times?	Freeze fault, air coil - no or low air flow	Check fan motor for proper operation.
					Check air filter
					Inspect air coil for dirt/debris
					Check duct work - are dampers closed or blocked?
				Freeze fault, air coil - blocked return air	Check that there is adequate space between the return air opening and walls or other obstructions on free return applications.
	Freeze fault, air coil - low refrigerant	Check refrigerant pressure with gauge set.			
	X	X	No fault LED - contactor not energized	Thermostat not calling for compressor operation	Ensure that the thermostat is on and calling for "Y"
				Bad thermostat connection	Check "Y" connection from thermostat. Insure that there is 24 VAC between "Y" and "C".
				Loose wire to contactor coil	Check wiring - insure that there is 24 VAC across the contactor coil.
Burned out contactor coil				Test contactor with 24VAC (between "R" and "C"). Ohm contactor coil - an open circuit indicates a burned coil.	

**Table 9: UNIT TROUBLESHOOTING**

Problem	Mode		Check	Possible Cause	Action
<b>No compressor operation but fan runs</b>	X	X	No fault LED - contactor energized	Open compressor overload	Check for supply voltage at the load side of the contactor. For 3 phase models check phase rotation and voltage at all 3 phases.
				Poor wiring connections	Look for signs of heat on the wiring insulation. Check that all wiring connections are secure and properly torqued.
				Burned out compressor	Does compressor hum when power is applied? If not check the resistance of the compressor windings using the values shown in the compressor characteristics chart. Note that the compressor must be cool (70° F) when checking the windings.
<b>No compressor or fan operation</b>	X	X	Power LED on	Bad thermostat connection / faulty thermostat	Check thermostat and wiring. Check unit terminal block for 24 VAC between "Y" and "C" and "G" and "C".
			Power LED off	Low or no supply power	Insure that the supply voltage to the unit is with in the range shown on the unit data plate.
				Faulty control transformer	Check for 24 VAC between "R" and "C" on the unit terminal block. For 75 and 100 VA transformers, check that the transformer circuit breaker has not tripped. Check low voltage circuit for overload conditons or short circuits before replacing the transformer.
<b>No fan operation - PSC motor</b>	X	X	Fan relay energized	Faulty motor	check supply voltage from the fan relay to the motor. Check that all motor wires are secure. With power off spin the motor shaft - noise, resistance or uneven motion can be signs of motor failure.
			Fan relay not energized	No fan operation signal	Check for 24 VAC across the fan relay coil. Check all wiring connections.
				Bad fan relay	If the relay coil is energized but the relay does not pull in, check the resistance across the relay coil - an open circuit is an indicator of a faulty relay.
<b>No fan operation - constant torque motor</b>	X	X		No fan operation signal	Check for 24 VAC between "G" and "C". Check all wiring connections.
				Loose wiring	Check all wiring connections at motor and control box.
				Faulty motor	Check supply voltage to the motor. Check that all motor wires are secure. With power off spin the motor shaft - noise, resistance or uneven motion can be signs of motor failure.



**Table 9: UNIT TROUBLESHOOTING**

Problem	Mode		Check	Possible Cause	Action
<b>No fan operation - constant airflow motor</b>	X	X		No fan operation signal	Check for 24 VAC between "G" and "C". Check all wiring connections. Make sure that the thermostat connection plug is securely connected.
				Loose wiring	Check all wiring connections at motor and control box. Check that power and control harnesses are securely connected.
				Interface board problems	Make sure that the interface board is not damaged and that all DIP switches are in the proper configuration (refer to the blower performance tables).
				Faulty motor	Check supply voltage to the motor. Check that all motor wires are secure. Move the "TEST" DIP switch to "ON" and the other switches to "OFF" on the "ADJUST" switch block on the interface board - the motor should run at 70% torque when "G" is called. With power off spin the motor shaft - noise, resistance or uneven motion can be signs of motor failure.
<b>Unit not shifting into cooling</b>	X		Reversing valve solenoid energized	Faulty solenoid	Check that the reversing valve solenoid is receiving 24 VAC. If so, check the resistance of the solenoid - an open circuit may indicate a burned out solenoid.
			Reversing valve solenoid not energized	Miswired/faulty thermostat	Check that the reversing valve thermostat wire is connected to the "O" terminal of the thermostat. Check for a contact closure between "O" and "R".
				Loose wire on "O" terminal	Check that the wires from the thermostat to the unit are securely connected and that the wires from the electrical box to the reversing valve are connected.
<b>Excessively cold supply air temperature in cooling or excessively hot supply air temperature in heating</b>	X	X	Reduced air flow	Dirty Filter	Replace filter.
				Fan speed too low	Consult blower performance table and increase fan speed if possible.
				Excessive duct pressure drop	Consult blower performance table and increase fan speed if possible.
<b>Excessively warm supply air temperature in cooling and/or excessively cool air in heating</b>	X	X	Air flow too high	Fan speed setting too high	Consult blower performance table and reduce fan speed if possible.
			High or low water temperature	Inlet water temperature out of range	Check unit capacity vs. water temperature.
			Air leakage	Leaky duct work	Inspect duct work.
			Loss of refrigeration capacity	Low refrigerant	Check refrigerant pressures with gauge set.

**Table 9: UNIT TROUBLESHOOTING**

Problem	Mode		Check	Possible Cause	Action
<b>High humidity</b>	X		Air flow too high	Fan speed setting too high	Consult blower performance table and reduce fan speed if possible.
			Loss of refrigeration capacity	Low refrigerant	Check refrigerant pressures with gauge set.
			Short cycling	Unit oversized	Check unit performance against building load calculations.
				Poor thermostat location	Make sure that thermostat is not located by a supply air duct .
<b>Objectionable noise levels</b>	X	X	Air noise	Poor duct work/grille design	Insure duct work and grilles are properly sized for unit air flow.
				Fan speed setting too high	Consult blower performance table and reduce fan speed if possible.
			Structure bourne noise	Unit not mounted on full vibration pad	Mount unit on a vibration pad (see page 7).
				Unit not connected with flexible conduit, water lines and/or duct work	Install unit in accordance with instructions on pages 6-8.
				Unit cabinet touching wall or other building component	Adjust unit location to avoid unit touching structure.
	X		Compressor noise	High water temperature or low water flow rate elevating head pressure	Increase water flow rate and/or reduce water temperature if possible.
				Scaled or fouled water coil elevating heat pressure	Clean/descale water coil.
				Low air flow elevating head pressure	Check filter.
	Increase fan speed.				
	X	X	Water hammer	Fast closing valves installed	change valves to slow-close type.

# OPERATING TEMPERATURES AND PRESSURES

OPERATING DATA										
MODEL	ENTERING WATER TEMP, °F	WATER FLOW GPM	COOLING				HEATING			
			SUCTION PRESSURE PSIG	DISCHARGE PRESSURE PSIG	WATER TEMP RISE, °F	AIR TEMP DROP, °F	SUCTION PRESSURE PSIG	DISCHARGE PRESSURE PSIG	WATER TEMP DROP, °F	AIR TEMP RISE, °F
LV018	30°	3					65-80	282-344	6-7	14-17
		5					73-89	294-359	3-4	15-18
	40°	3	121-148	184-225	17-21	18-22	80-98	299-365	7-9	16-20
		5	117-143	167-204	10-13	19-23	89-108	311-380	4-5	17-21
	50°	3	123-151	222-271	17-20	17-21	95-116	315-385	9-11	19-23
		5	119-145	202-247	10-12	18-23	105-128	329-402	5-7	20-24
	60°	3	125-153	260-318	16-19	17-21	109-133	332-406	11-13	21-26
		5	120-147	237-289	10-12	18-22	121-148	346-423	6-8	22-27
	70°	3	127-155	298-365	15-19	17-20	124-151	349-427	12-15	23-28
		5	122-149	271-331	9-11	18-21	138-168	364-444	7-9	25-30
	80°	3	129-158	336-411	14-18	16-20	138-169	366-447	14-17	26-31
		5	124-152	306-374	9-11	17-21	154-188	381-466	8-10	27-33
	90°	3	131-160	374-458	14-17	16-19	153-187	383-468	16-16	28-34
		5	126-154	340-416	8-10	17-20	170-208	399-487	9-12	29-36
100°	3	133-162	413-504	13-16	15-19					
	5	128-156	375-458	8-10	16-20					
LV024	30°	5					72-87	296-361	5-6	21-25
		7					75-92	301-368	3-4	22-26
	40°	5	114-139	155-190	14-17	22-27	88-107	314-384	6-7	24-29
		7	108-132	147-180	10-12	23-28	92-112	321-392	4-5	25-30
	50°	5	116-142	192-234	13-16	21-26	104-127	333-407	7-9	27-33
		7	111-135	182-222	9-12	22-27	109-133	340-415	5-6	28-34
	60°	5	119-146	228-279	13-16	21-26	120-146	352-430	8-10	30-37
		7	113-138	217-265	9-11	22-27	125-153	359-439	6-7	32-39
	70°	5	122-149	264-323	13-15	20-25	136-166	371-453	9-12	33-41
		7	116-142	251-307	9-11	21-26	142-174	378-462	7-8	35-43
	80°	5	125-152	301-368	12-15	20-24	152-185	389-476	11-13	36-44
		7	118-145	286-349	9-11	21-26	159-194	397-485	8-9	38-47
	90°	5	127-156	337-412	12-15	19-24	168-205	408-499	12-15	39-48
		7	121-148	320-392	9-10	20-25	176-215	416-509	8-10	41-51
100°	5	130-159	374-457	12-14	19-23					
	7	124-151	355-434	8-10	20-24					

This chart shows approximate temperatures and pressures for a unit in good repair. The values shown are meant as a guide only and should not be used to estimate system charge. This chart assumes rated air flow and 80° d.b./67° w.b. entering air temperature in cooling, 70° d.b. entering air temperature in heating. Heating data at entering fluid temperatures below 50° assumes the use of antifreeze. As a result of continuing research and development, specifications are subject to change without notice.

OPERATING DATA										
MODEL	ENTERING WATER TEMP, °F	WATER FLOW GPM	COOLING				HEATING			
			SUCTION PRESSURE PSIG	DISCHARGE PRESSURE PSIG	WATER TEMP RISE, °F	AIR TEMP DROP, °F	SUCTION PRESSURE PSIG	DISCHARGE PRESSURE PSIG	WATER TEMP DROP, °F	AIR TEMP RISE, °F
LV030	30°	3.5					73-89	266-325	5-6	15-18
		7.5					77-94	272-333	3-4	16-19
	40°	3.5	117-143	189-231	14-17	18-22	86-105	279-341	6-7	17-21
		7.5	112-137	178-217	8-9	19-24	90-110	286-350	4-5	18-22
	50°	3.5	126-154	221-270	14-17	18-21	162-198	293-358	7-8	20-24
		7.5	121-148	207-253	8-9	19-23	170-208	300-366	5-6	21-25
	60°	3.5	131-160	252-308	13-16	17-21	110-134	306-374	8-10	22-27
		7.5	125-153	237-290	8-9	18-22	115-141	314-383	6-7	23-29
	70°	3.5	135-165	284-347	13-16	17-20	122-150	320-391	9-11	24-30
		7.5	130-158	266-326	7-9	18-22	129-157	327-400	6-8	26-32
	80°	3.5	140-171	320-391	13-16	16-20	134-164	333-407	11-13	27-33
		7.5	134-164	300-367	7-9	17-21	141-172	341-417	7-9	28-35
	90°	3.5	144-176	360-440	13-16	16-19	147-179	347-424	12-14	29-36
		7.5	138-169	338-414	7-9	17-21	154-188	355-434	8-10	31-38
100°	3.5	149-182	405-495	13-15	15-19					
	7.5	143-174	381-465	7-9	16-20					
LV036	30°	4.5					74-90	244-299	3-4	13-15
		9					78-95	251-306	2-3	13-16
	40°	4.5	122-149	183-224	14-18	19-23	87-106	257-314	4-5	15-18
		9	117-143	172-210	8-10	20-24	91-111	263-322	3-3	16-19
	50°	4.5	131-160	214-261	14-18	18-22	164-201	269-329	5-6	17-20
		9	126-154	201-245	8-10	19-24	173-211	276-337	3-4	18-22
	60°	4.5	136-166	244-298	14-17	18-22	111-136	282-344	6-7	19-23
		9	131-160	230-281	8-10	19-23	117-143	289-353	4-5	20-24
	70°	4.5	141-172	275-336	14-17	17-21	124-152	294-360	7-8	21-25
		9	135-165	258-316	8-10	18-22	131-160	302-369	5-6	22-27
	80°	4.5	145-178	310-378	14-17	17-20	136-166	307-375	8-9	23-28
		9	140-171	291-356	8-10	18-22	143-175	314-384	5-6	24-30
	90°	4.5	150-183	349-426	14-17	16-20	149-182	319-390	8-10	25-30
		9	144-176	328-401	8-9	17-21	156-191	327-400	6-7	26-32
100°	4.5	155-189	392-480	13-16	16-19					
	9	149-182	369-451	8-9	17-21					

This chart shows approximate temperatures and pressures for a unit in good repair. The values shown are meant as a guide only and should not be used to estimate system charge. This chart assumes rated air flow and 80° d.b./67° w.b. entering air temperature in cooling, 70° d.b. entering air temperature in heating. Heating data at entering fluid temperatures below 50° assumes the use of antifreeze. As a result of continuing research and development, specifications are subject to change without notice.

OPERATING DATA										
MODEL	ENTERING WATER TEMP, °F	WATER FLOW GPM	COOLING				HEATING			
			SUCTION PRESSURE PSIG	DISCHARGE PRESSURE PSIG	WATER TEMP RISE, °F	AIR TEMP DROP, °F	SUCTION PRESSURE PSIG	DISCHARGE PRESSURE PSIG	WATER TEMP DROP, °F	AIR TEMP RISE, °F
LV042	30°	6					64-78	248-303	5-6	15-18
		10					67-82	254-311	3-4	16-19
	40°	6	109-134	183-224	18-22	19-23	75-91	261-319	6-8	17-21
		10	105-128	172-210	10-12	20-25	79-96	267-327	4-5	18-23
	50°	6	118-144	214-261	18-22	19-23	142-173	273-334	8-10	20-24
		10	113-138	201-245	10-12	20-24	149-182	280-342	5-7	21-26
	60°	6	122-149	244-298	17-21	18-22	96-117	286-349	9-11	22-27
		10	117-143	230-281	10-12	19-24	101-123	293-358	6-8	24-29
	70°	6	126-154	275-336	17-21	18-22	107-131	299-365	11-13	25-30
		10	121-148	258-316	10-12	19-23	113-138	306-374	7-9	26-32
	80°	6	130-159	310-378	17-21	17-21	117-143	311-380	12-15	27-33
		10	125-153	291-356	10-12	18-22	123-151	319-390	8-10	29-35
	90°	6	134-164	349-426	17-20	17-20	128-157	324-396	13-16	29-36
		10	129-158	328-401	9-12	18-22	135-165	332-406	9-11	31-38
100°	6	139-170	392-480	16-20	16-20					
	10	133-163	369-451	9-11	17-21					
LV048	30°	6					71-87	277-339	6-7	15-19
		10					75-92	284-347	4-5	16-20
	40°	6	118-144	194-237	21-25	19-23	84-102	291-356	7-9	18-22
		10	113-138	182-223	12-14	20-24	88-108	299-365	5-6	19-23
	50°	6	127-155	226-276	21-25	18-22	159-194	305-373	9-11	20-25
		10	122-149	213-260	12-14	19-24	167-204	313-383	6-7	21-26
	60°	6	131-160	259-316	21-25	18-22	108-132	320-391	10-13	23-28
		10	126-154	243-297	12-14	19-23	113-138	328-400	7-9	24-29
	70°	6	136-166	291-355	20-25	17-21	120-147	334-408	12-15	25-31
		10	130-159	273-334	12-14	18-22	126-154	342-418	8-10	27-32
	80°	6	140-171	328-401	20-24	17-20	131-161	348-425	14-17	27-34
		10	135-165	308-377	11-14	18-22	138-169	356-436	9-11	29-36
	90°	6	145-177	369-451	20-24	16-20	144-176	362-442	15-18	30-37
		10	139-170	347-424	11-14	17-21	151-185	371-453	10-12	32-39
100°	6	149-183	415-508	19-24	16-19					
	10	143-175	391-477	11-14	17-21					

This chart shows approximate temperatures and pressures for a unit in good repair. The values shown are meant as a guide only and should not be used to estimate system charge. This chart assumes rated air flow and 80° d.b./67° w.b. entering air temperature in cooling, 70° d.b. entering air temperature in heating. Heating data at entering fluid temperatures below 50° assumes the use of antifreeze. As a result of continuing research and development, specifications are subject to change without notice.

OPERATING DATA										
MODEL	ENTERING WATER TEMP, °F	WATER FLOW GPM	COOLING				HEATING			
			SUCTION PRESSURE PSIG	DISCHARGE PRESSURE PSIG	WATER TEMP RISE, °F	AIR TEMP DROP, °F	SUCTION PRESSURE PSIG	DISCHARGE PRESSURE PSIG	WATER TEMP DROP, °F	AIR TEMP RISE, °F
LV060	30°	8					68-84	256-313	5-7	19-23
		12					73-89	261-319	4-5	20-25
	40°	8	113-138	173-212	18-22	19-23	81-99	277-339	7-8	22-26
		12	110-134	162-198	12-14	20-24	86-105	283-346	5-6	23-28
	50°	8	116-142	207-253	17-21	19-23	93-114	299-365	8-9	24-29
		12	112-137	193-236	12-14	19-24	99-121	305-373	6-7	25-31
	60°	8	118-145	240-293	17-21	18-23	106-129	321-392	9-11	26-32
		12	115-140	224-274	11-14	19-23	113-138	327-400	7-8	28-34
	70°	8	121-148	273-334	17-21	18-22	118-145	342-418	10-12	29-35
		12	117-143	255-312	11-14	19-23	126-154	349-427	8-9	30-37
	80°	8	123-151	307-375	16-20	18-22	131-160	364-444	11-14	31-38
		12	120-146	287-350	11-13	19-23	139-170	371-454	8-10	33-40
	90°	8	126-154	340-416	16-20	18-22	143-175	385-471	12-15	33-41
		12	122-149	318-388	11-13	18-22	152-186	393-480	9-11	35-43
100°	8	128-157	373-456	16-19	17-21					
	12	125-152	349-426	11-13	18-22					
LV070	30°	12					68-84	256-313	5-7	19-23
		16					73-89	261-319	4-5	20-25
	40°	12	117-143	182-222	15-19	21-26	81-99	277-339	7-8	22-26
		16	114-139	170-208	11-14	22-27	86-105	283-346	5-6	23-28
	50°	12	120-147	215-263	15-18	20-25	93-114	299-365	8-9	24-29
		16	117-143	201-246	11-14	21-26	99-121	305-373	6-7	25-31
	60°	12	123-150	248-304	14-17	20-24	106-129	321-392	9-11	26-32
		16	119-146	232-284	11-13	21-25	113-138	327-400	7-8	28-34
	70°	12	126-154	282-344	14-17	19-24	118-145	342-418	10-12	29-35
		16	122-149	263-322	10-13	20-25	126-154	349-427	8-9	30-37
	80°	12	129-157	315-385	13-16	19-23	131-160	364-444	11-14	31-38
		16	125-153	294-360	10-12	19-24	139-170	371-454	8-10	33-40
	90°	12	132-161	348-426	13-16	18-22	143-175	385-471	12-15	33-41
		16	128-156	326-398	10-12	19-23	152-186	393-480	9-11	35-43
100°	12	134-164	382-466	12-15	17-21					
	16	131-160	357-436	9-11	18-22					

This chart shows approximate temperatures and pressures for a unit in good repair. The values shown are meant as a guide only and should not be used to estimate system charge. This chart assumes rated air flow and 80° d.b./67° w.b. entering air temperature in cooling, 70° d.b. entering air temperature in heating. Heating data at entering fluid temperatures below 50° assumes the use of antifreeze. As a result of continuing research and development, specifications are subject to change without notice.

## COMPRESSOR CHARACTERISTICS

Model	Voltage Code	Rated Voltage	Compressor Data Plate			Cold Winding Resistance Values (+/- 10%)			Run Capacitor (µF/V)
			Phase	RLA	LRA	Single Phase		Three Phase	
						R-C	S-C	Line-Line	
LV018	1	208-230/1/60	1	6.5	43	1.431	2.383	-	30/370
	2	265/1/60	1	5.8	46	1.4	2.4	-	30/440
LV024	1	208-230/1/60	1	7.4	43	1.431	2.383	-	35/370
	2	265/1/60	1	6.7	46	1.4	2.4	-	30/440
	3	208-230/3/60	3	5.9	63	-	-	1.362	-
	4	460/3/60	3	2.9	30	-	-	5.329	-
LV030	1	208-230/1/60	1	9.9	54	0.982	1.729	-	35/370
	2	265/1/60	1	8.5	46	1.4	2.46	-	30/440
	3	208-230/3/60	3	6.9	63	-	-	1.362	-
	4	460/3/60	3	3.6	30	-	-	5.329	-
LV036	1	208-230/1/60	1	13.0	74	0.819	1.634	-	40/370
	2	265/1/60	1	11.3	67	0.802	1.76	-	35/440
	3	208-230/3/60	3	7.8	68	-	-	1.152	-
	4	460/3/60	3	3.9	34	-	-	4.606	-
LV042	1	208-230/1/60	1	13.6	88	0.656	1.558	-	45/370
	2	265/1/60	1	12.0	67	0.802	1.76	-	35/370
	3	208-230/3/60	3	8.8	68	-	-	1.152	-
	4	460/3/60	3	4.4	34	-	-	4.606	-
LV048	1	208-230/1/60	1	15.7	84	0.54	1.6	-	45/370
	3	208-230/3/60	3	11.0	88	-	-	0.928	-
	4	460/3/60	3	5.4	44	-	-	3.593	-
	5	575/3/60	3	4.4	36	-	-	5.678	-
LV060	1	208-230/1/60	1	26.3	134	0.453	0.792	-	80/370
	3	208-230/3/60	3	15.6	110	-	-	0.68	-
	4	460/3/60	3	7.8	52	-	-	3.2	-
	5	575/3/60	3	5.8	38.9	-	-	5.33	-
LV070	1	208-230/1/60	1	28.3	178	0.97	0.365	-	80/370
	3	208-230/3/60	3	19.2	136	-	-	0.6	-
	4	460/3/60	3	8.7	67.1	-	-	2.52	-
	5	575/3/60	3	6.9	55.3	-	-	3.74	-

WIRING DIAGRAMS

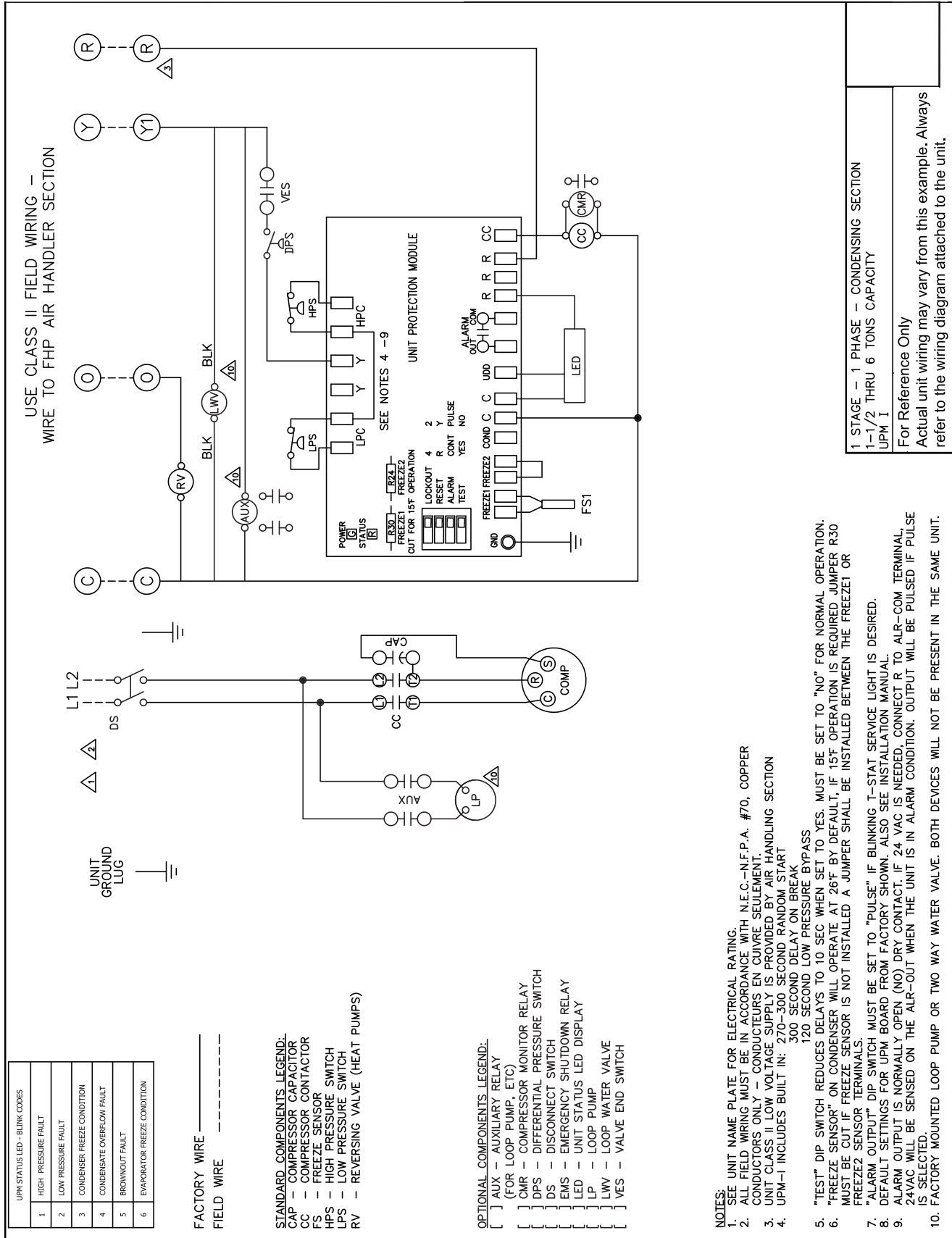

Figure # 7



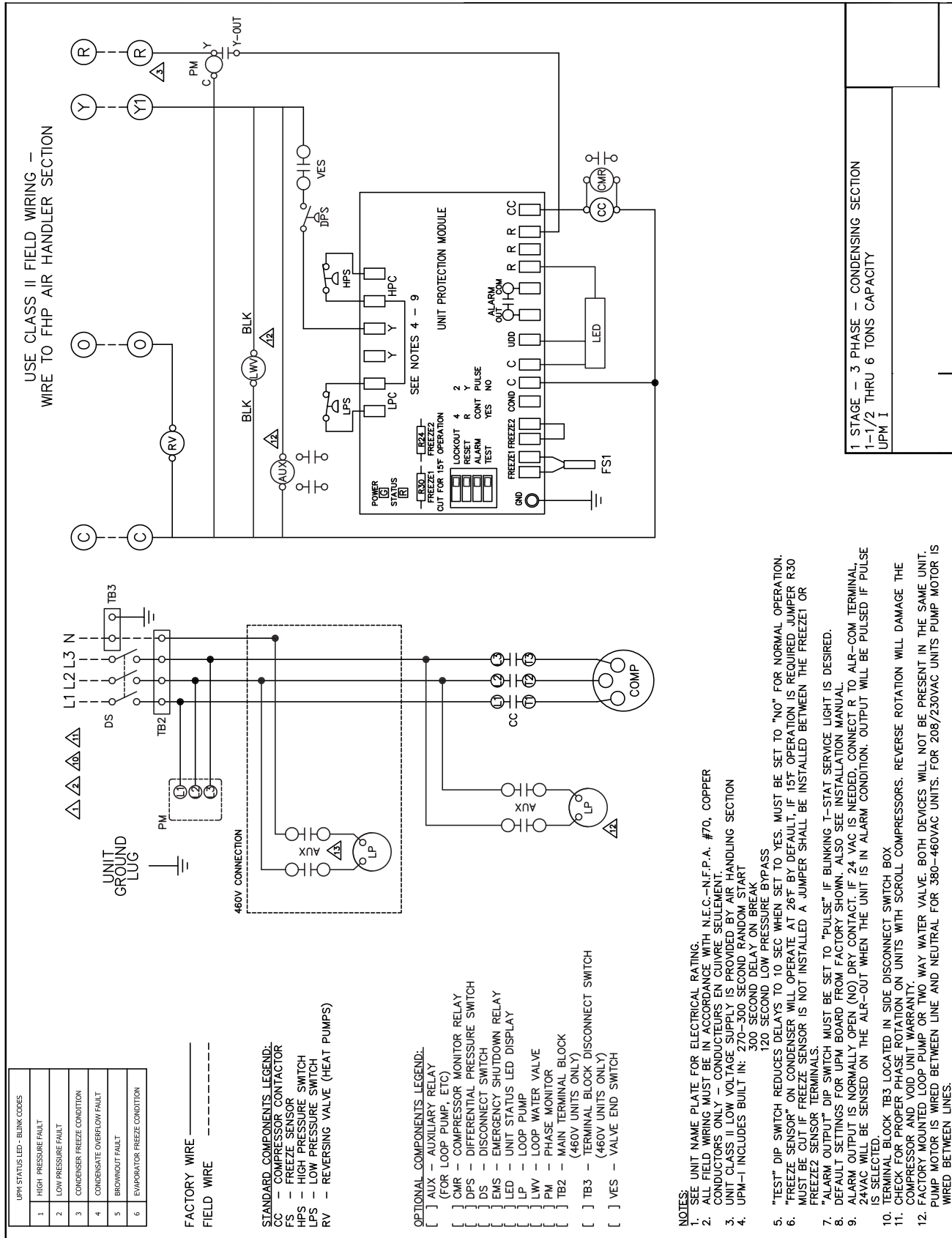

Figure # 8

- NOTES:**
- SEE UNIT NAME PLATE FOR ELECTRICAL RATING.
  - ALL FIELD WIRING MUST BE IN ACCORDANCE WITH N.E.C.-N.F.P.A. #70, COPPER CONDUCTORS ONLY - CONDUCTEURS EN CUivre SEULEMENT.
  - UNIT CLASS II LOW VOLTAGE SUPPLY IS PROVIDED BY AIR HANDLING SECTION
  - UPM-I INCLUDES BUILT IN: 270-300 SECOND RANDOM START  
300 SECOND DELAY ON BREAK  
120 SECOND LOW PRESSURE BYPASS
  - "TEST" DIP SWITCH REDUCES DELAYS TO 10 SEC WHEN SET TO "YES. MUST BE SET TO "NO" FOR NORMAL OPERATION.
  - "FREEZE SENSOR" ON CONDENSER WILL OPERATE AT 26°F BY DEFAULT, IF 15°F OPERATION IS REQUIRED, JUMPER R30 MUST BE CUT TO SET FREEZE SENSOR TO 15°F. FREEZE SENSOR IS NOT INSTALLED A JUMPER SHALL BE INSTALLED BETWEEN THE FREEZEZ OR FREEZEZ SENSOR TERMINALS.
  - "ALARM" OUTPUT DIP SWITCH MUST BE SET TO "PULSE" IF BLINKING T-STAT SERVICE LIGHT IS DESIRED.
  - DEFAULT SETTINGS FOR UPM BOARD FROM FACTORY SHOWN. ALSO SEE INSTALLATION MANUAL.
  - ALARM OUTPUT IS NORMALLY OPEN (NO) DRY CONTACT. IF 24 VAC IS NEEDED, CONNECT R TO ALR-COM TERMINAL. 24VAC WILL BE SENSED ON THE ALR-OUT WHEN THE UNIT IS IN ALARM CONDITION. OUTPUT WILL BE PULSED IF PULSE IS SELECTED.
  - TERMINAL BLOCK TB3 LOCATED IN SIDE DISCONNECT SWITCH BOX
  - CHECK FOR PROPER PHASE ROTATION ON UNITS WITH SCROLL COMPRESSORS. REVERSE ROTATION WILL DAMAGE THE COMPRESSOR AND VOID UNIT WARRANTY.
  - FACTORY MOUNTED LOOP PUMP OR TWO WAY WATER VALVE. BOTH DEVICES WILL NOT BE PRESENT IN THE SAME UNIT. PUMP MOTOR IS WIRED BETWEEN LINE AND NEUTRAL FOR 380-460VAC UNITS. FOR 208/230VAC UNITS PUMP MOTOR IS WIRED BETWEEN LINES.

**DIMENSIONAL DRAWINGS**

Model	A	B	C	D	E	F	G	H	J	WATER CONNECTIONS	K	L	SERVICE VALVE GAS CONNECTION	M	N	SERVICE VALVE LIQUID CONNECTION
	WIDTH	DEPTH	HEIGHT	WATER IN	WATER OUT	LIQUID CONNECTION	SUCTION CONNECTION	ELECTRICAL KNOCKOUT		CONNECTIONS	SERVICE VALVE GAS		SERVICE VALVE GAS CONNECTION	SERVICE VALVE LIQUID		SERVICE VALVE LIQUID CONNECTION
LV018_024-CS	21.5	21.5	19.00	2.8	8.5	3/8"	3/4"	3.6	10.7	3/4" F.P.T.	1.6	5.7	3/8 OD	1.9	7.5	3/4 ID
LV030-CS	21.5	21.5	19.00	2.8	9.8	3/8"	3/4"	3.6	10.7	3/4" F.P.T.	1.6	5.7	3/8 OD	1.9	7.5	3/4 ID
LV036_042-CS	21.5	26.0	19.00	2.8	10.8	3/8"	3/4"	3.6	10.7	3/4" F.P.T.	1.6	7.0	3/8 OD	1.9	8.8	3/4 ID
LV048-CS	24.0	32.5	21.00	3.3	13.2	3/8"	3/4"	3.6	10.7	1" F.P.T.	1.6	5.2	3/8 OD	1.9	7.1	3/4 ID
LV060-CS	24.0	32.5	21.00	3.3	13.2	3/8"	1"	3.6	10.7	1" F.P.T.	1.6	5.2	3/8 OD	1.9	7.1	7/8 ID
LV070-CS	26.0	33.3	21.00	2.9	13.4	3/8"	1"	3.6	10.7	1" F.P.T.	1.6	8.4	3/8 OD	1.9	10.2	7/8 ID

All dimensions within  $\pm 0.125$ .  
 All dimensions in inches.  
 Specifications subject to change without notice

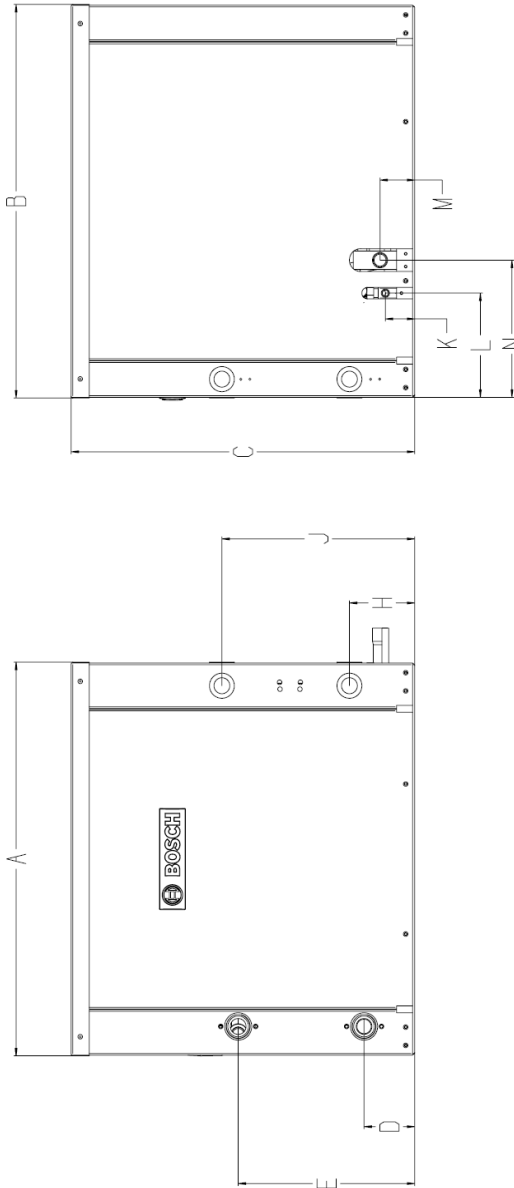

## NOTES



# BOSCH

601 N.W. 65th Court, Ft. Lauderdale, FL 33309  
Phone: 866-642-3198 | Fax: 954-776-5529  
[www.boshtaxcredit.com](http://www.boshtaxcredit.com) | [www.FHP-MFG.com](http://www.FHP-MFG.com)  
Revised 01-15

