

LV Air Handler



**BOSCH**

## Installation, Operation and Maintenance Manual

8 733 922 118 (2015/01)

## CONTENTS

Condensing Section/Air Handler Pairing .....	2
Key to Symbols .....	3
Safety Warnings .....	3
<b>GENERAL DESCRIPTION</b> .....	4
<b>MOVING AND STORAGE</b> .....	4
<b>INITIAL INSPECTION</b> .....	4
<b>SAFETY CONSIDERATIONS</b> .....	5
<b>LOCATION</b> .....	5
Air Handler .....	5
Condensing Section .....	5
<b>INSTALLATION</b> .....	5
Air Handler .....	5
<b>HANGING BRACKET KIT</b> .....	6
<b>CONDENSATE DRAIN</b> .....	7
Duct Flanges .....	7
<b>DUCT SYSTEM</b> .....	7
<b>Electrical</b> .....	8
- High Voltage .....	8
- Low Voltage .....	8
Electronic Thermostat Installation .....	9
Thermostat Connections .....	9
<b>OPTIONS</b> .....	10
Unit Mounted Non-Fused Disconnect Switch .....	10
<b>REFRIGERANT LINES</b> .....	10
Linear vs Equivalent Line Length .....	11
Connecting Refrigerant Lines .....	11
<b>Charging the system</b> .....	12
Pre-charge adjustment .....	12
Final charge adjustment .....	14
Determining Sub-Cooling .....	14
Determining Superheat .....	15
<b>Sequence of Operation</b> .....	17
Cooling and Heating Modes .....	17
Constant Torque Motors (ECM) .....	17
Constant Airflow Motors (ECM) .....	19
<b>Application Considerations</b> .....	23
Well Water Systems .....	23
Cooling Tower/Boiler Systems .....	23
Geothermal Systems .....	26
<b>System Checkout</b> .....	27
<b>Unit Start-up</b> .....	27
<b>Maintenance</b> .....	28

Troubleshooting .....	29
Wiring Diagrams .....	34
Dimensional Drawings .....	35

## CONDENSING SECTION/AIR HANDLER PAIRING

UNIT MODEL	Paired Air Handler	
	Unit 1	Unit 2
LV018-1CSC	LV018-1AVX	LV018-1AHX
LV018-2CSC	LV018-2AVX	LV018-2AHX
LV024-1CSC	LV024-1AVX	LV024-1AHX
LV024-2CSC	LV024-2AVX	LV024-2AHX
LV024-3CSC	LV024-1AVX	LV024-1AHX
LV024-4CSC	LV024-4AVX	LV024-4AHX
LV030-1CSC	LV030-1AVX	LV030-1AHX
LV030-2CSC	LV030-2AVX	LV030-2AHX
LV030-3CSC	LV030-1AVX	LV030-1AHX
LV030-4CSC	LV030-4AVX	LV030-4AHX
LV036-1CSC	LV036-1AVX	LV036-1AHX
LV036-2CSC	LV036-2AVX	LV036-2AHX
LV036-3CSC	LV036-1AVX	LV036-1AHX
LV036-4CSC	LV036-4AVX	LV036-4AHX
LV042-1CSC	LV042-1AVX	LV042-1AHX
LV042-3CSC	LV042-1AVX	LV042-1AHX
LV042-4CSC	LV042-4AVX	LV042-4AHX
LV048-1CSC	LV048-1AVX	LV048-1AHX
LV048-3CSC	LV048-1AVX	LV048-1AHX
LV048-4CSC	LV048-4AVX	LV048-4AHX
LV060-1CSC	LV060-1AVX	LV060-1AHX
LV060-3CSC	LV060-1AVX	LV060-1AHX
LV060-4CSC	LV060-4AVX	LV060-4AHX
LV070-1CSC	LV070-1AVX	LV070-1AHX
LV070-3CSC	LV070-1AVX	LV070-1AHX
LV070-4CSC	LV070-4AVX	LV070-4AHX

### LV AH MODEL NOMENCLATURE

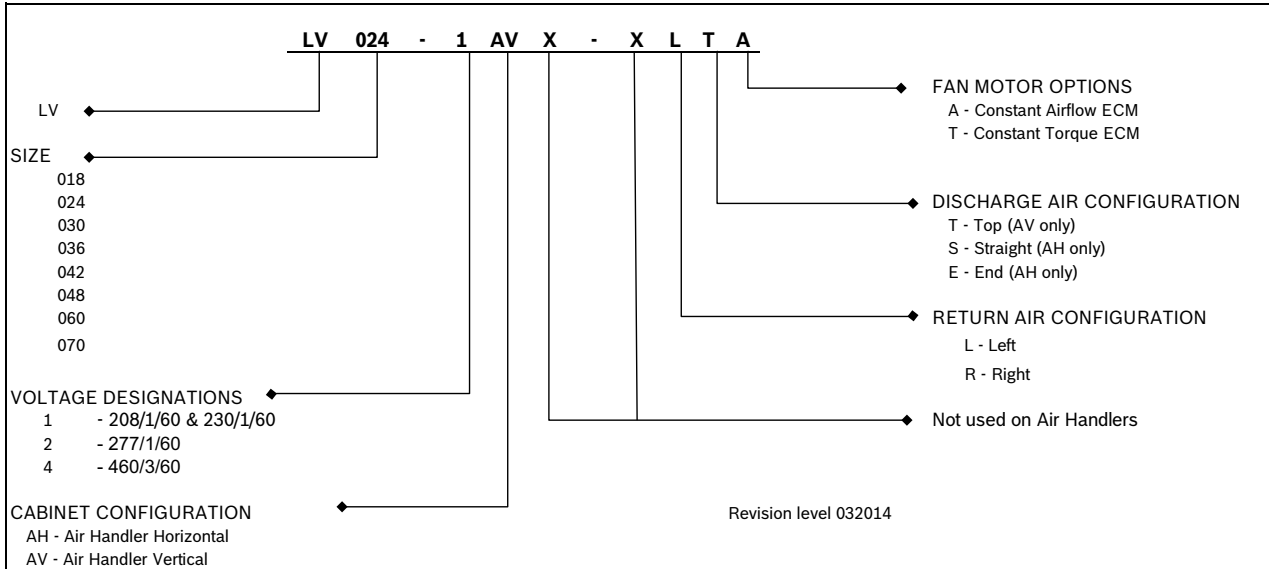

### KEY TO SYMBOLS

#### Warnings



Warnings in this document are identified by a warning triangle printed against a grey background. Keywords at the start of the warning indicate the type and seriousness of the ensuing risk if measures to prevent the risk are not taken.

The following keywords are defined and can be used in this document:

- **NOTE** indicates a situation that could result in damage to property or equipment.
- **CAUTION** indicates a situation that could result in minor to medium injury.
- **WARNING** indicates a situation that could result in severe injury or death.
- **DANGER** indicates a situation that will result in severe injury or death.

#### Important Information



This symbol indicates important information where there is no risk to property or people.

### SAFETY WARNINGS



Installation and servicing of this equipment can be hazardous due to system pressure and electrical components. Only trained and qualified personnel should install, repair, or service the equipment.



Before performing service or maintenance operations on the system, turn off main power to the unit. **Electrical shock could cause personal injury or death.**



When working on equipment, always observe precautions described in the literature, tags, and labels attached to the unit. Follow all safety codes. Wear safety glasses and work gloves. Use a quenching cloth for brazing, and place a fire extinguisher close to the work area.



To avoid the release of refrigerant into the atmosphere, the refrigerant circuit of this unit must be serviced only by technicians who meet local, state, and federal proficiency requirements.



All refrigerant discharged from this unit must be recovered **WITHOUT EXCEPTION**. Technicians must follow industry accepted guidelines and all local, state, and federal statutes for the recovery and disposal of refrigerants. If a compressor is removed from this unit, refrigerant circuit oil will remain in the compressor. To avoid leakage of compressor oil, refrigerant lines of the compressor must be sealed after it is removed.



To avoid equipment damage, **DO NOT** use these units as a source of heating or cooling during the construction process. Doing so may affect the unit's warranty. The mechanical components and filters will quickly become clogged with construction dirt and debris, which may cause system damage.

## GENERAL DESCRIPTION

These water-to-air heat pumps provide an unmatched combination of performance, features and flexibility for both high performance new construction applications and replacement of existing water-to-air heat pumps. All units are certified by the Air conditioning, Heating and Refrigeration Institute (AHRI) to AHRI/ANSI/ASHRAE/ISO standard 13256-1 for water-to-air and brine-to-air heat pumps at both Water Loop Heat Pump and Ground Loop Heat Pump application points.

These units are safety listed with Intertek Test Labs (ETL) to cUL standard 1995 and certified to CAN/CSA C22.1 No 236. These units meet all current applicable requirements of ASHRAE 90.1. Safety devices are built into each unit to provide the maximum system protection possible when properly installed and maintained.

Split system heat pumps consist of two independently installed sections allowing for centralized air distribution while remotely locating the section containing the compressor and water-to-refrigerant heat exchanger.

In the cooling mode, the air coil in the air handler section serves as an evaporator and the water-to-refrigerant heat exchanger serves as a condenser. In the heating mode, their roles are reversed. The refrigerant lines connecting the two sections consist of one line carrying liquid refrigerant and another carrying refrigerant vapor. The liquid carrying line will be referred to as the liquid line while the vapor carrying line will be referred to as the suction line.

Air handler units are available in two basic configurations: vertical top supply air (AV) and horizontal end supply air or straight through supply air (AH). Each configuration is available with either left or right hand return air. HZ models can have the supply air field converted from end discharge air to straight through with no extra parts required. LV splits are designed and rated for indoor installation only. The units can accommodate a wide range of air temperatures but should not be installed in environments that fall below freezing or exceed 100°F ambient. The cabinets are constructed of heavy gauge G-90 galvanized steel and will resist most common types of corrosion for the life of the equipment.



**NOTE:** This product should not be used for temporarily heating/cooling during construction. Doing so may effect the unit's warranty.

### Several factory installed options are available:

MERV 8 & 13 Filters, Constant Airflow Motors, DuoGuard Air Coils and Closed Cell Foam Insulation

## MOVING AND STORAGE

If the equipment is not needed for immediate installation upon its arrival at the job site, it should be left in its packaging and stored in a clean, dry area. Units must only be stored or moved in the normal upright position.

## INITIAL INSPECTION

Be certain to inspect all packaging for each unit as received at the job site before signing the freight bill. Verify that all items have been received and that there are no visible damages; note any shortages or damages on all copies of the freight bill. In the event of damage or shortage, remember that the purchaser is responsible for filing the necessary claims with the carrier. Concealed damages not discovered until after removing the units from the packaging must be reported to the carrier within 24 hours of receipt.

## SAFETY CONSIDERATIONS

Installation and servicing of this equipment can be hazardous due to system pressure and electrical components. Only trained and qualified personnel should install, repair, or service the equipment. Untrained personnel can perform basic functions of maintenance such as cleaning coils and replacing filters.



**WARNING:** Before performing service or maintenance operations on the system, turn off main power to the unit. Electrical shock could cause personal injury or death.

When working on equipment, always observe precautions described in the literature, tags, and labels attached to the unit. Follow all safety codes. Wear safety glasses and work gloves. Use a quenching cloth for brazing, and place a fire extinguisher close to the work area.

## LOCATION

To maximize system performance, efficiency and reliability, and to minimize installation costs, it is always best to keep the refrigerant lines as short as possible. Every effort should be made to locate the air handler and the condensing section as close as possible to each other.

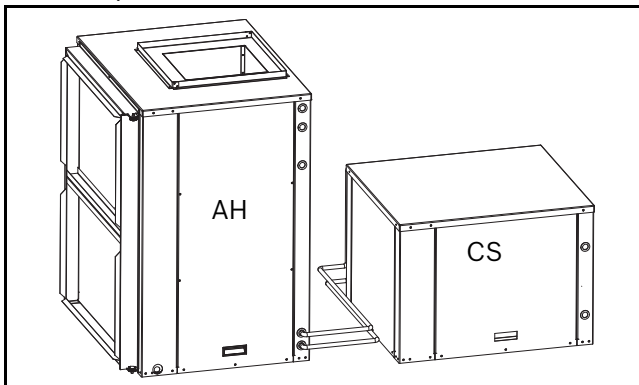

Figure # 1

## Air Handler

Locate the air handler unit in an indoor area that allows easy removal of the filter and access panels, and has enough room for service personnel to perform maintenance or repair. Provide sufficient room to make electrical and duct connections. If the unit is located in a confined space such as a closet, provisions must be made for return air to freely enter the space. On horizontal units, allow adequate room below the unit for a condensate drain trap.



The air handler units are not approved for outdoor installation; therefore, they must be installed inside the structure being conditioned. Do not locate in areas that are subject to freezing.

## Condensing Section

Locate the condensing section in an area that provides sufficient room to make water and electrical connections, and allows easy removal of the access panels for service personnel to perform maintenance or repair.



Reference the Condensing Section section of this manual for detailed installation and operation.

## INSTALLATION



Remove all shipping blocks from the inside and/or outside of the air handler section prior to final installation.



**NOTE:** The installer should comply with all local codes and regulations which govern the installation of this type of equipment. Local codes and regulations take precedent over any recommendations contained in these instructions. In light of local codes, the equipment should be installed in accordance with the recommendations made by the National Electric Code, and in accordance with the recommendations made by the National Board of Fire Underwriters.

## Air Handler

The air handler section may be installed on any level surface strong enough to support its weight. When installed in a closet or on a base stand, it should be mounted on a vibration absorbing pad slightly larger than the base to minimize vibration transmission to the building structure. A secondary drain pan should at all times be installed below the unit to capture condensate overflow and prevent water damage.

When installed in an attic or above a drop ceiling, the installation must conform to all local codes. When installed in the horizontal position (supply air at the end or side of the unit), the unit should be supported on all four corners with threaded rods attached to the building ceiling rafters and

utilizing the hanger kit found inside the cabinet of the horizontal air handler (Figure #). Refer to the hanging bracket assembly and installation instructions for details.

## HANGING BRACKET KIT

### Installation Instructions

All horizontal units come with Hanging Bracket kit to facilitate suspended unit mounting using threaded rod. Hanging Brackets are to be installed as shown in figure # 2

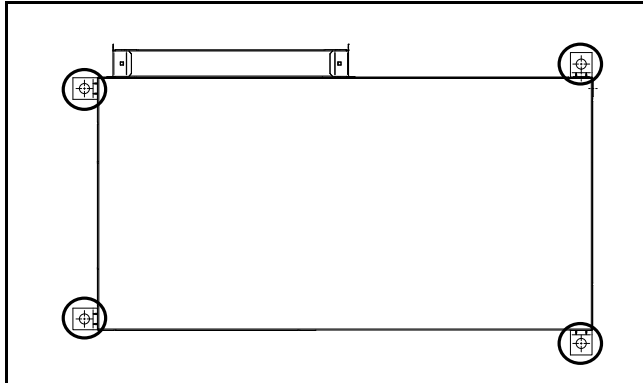

Figure # 2

This kit includes the following:

- (5) Brackets.
- (5) Rubber Vibrators Isolators.
- (8) Screws # 10x1/2"
- (10) Bolts 1/4-28x1/2" Hex Bolt (not used on this model)

The following are needed and are to be field provided:

- Threaded rod (3/8" max dia)
- Hex Nuts
- Washers (1-3/4" min O.D.)

1. Remove and discard factory provided screws from location where Hanging Brackets will be installed shown in Figure#3

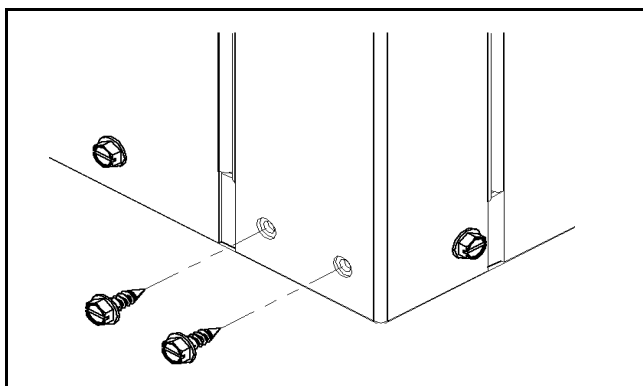

Figure # 3

2. Mount 5 brackets to unit corner post using the bolts provided in the kit as shown on Figure # 4



**WARNING:** Do not re-use screws removed from the unit on step 1 to mount the hanging Brackets to the unit.

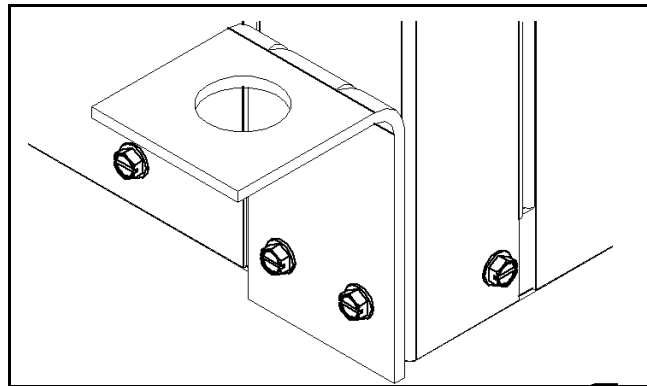

Figure # 4



**WARNING:** Follow all applicable codes requirements when hanging this unit. Selecting threaded rod material, etc.

3. Install Rubber Grommet on the Bracket as shown in Figure#5

4. Hang the unit and assemble the field provided Thread Rod, Nuts and washers on to the Brackets as shown in Figure#5



**CAUTION:** Rods must be securely anchored to the ceiling.

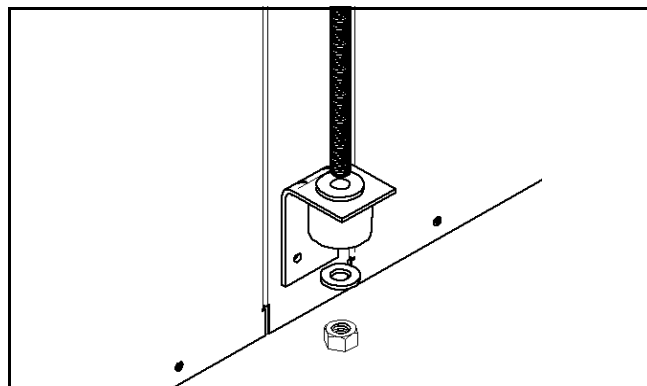

Figure # 5

Some applications require an attic floor installation of the air handling unit. In this case the unit should be set in a full size secondary drain pan on top of a vibration absorbing mesh. The secondary drain pan prevents possible condensate overflow or water leakage damage to the ceiling.

The secondary drain pan is usually placed on a plywood base isolated from the ceiling joists by additional layers of vibration absorbing mesh. In both cases, a 3/4" drain connected to this secondary pan should be run to an eave at a location that will be noticeable.

If the air handler is located in a crawl space, the bottom of the unit must be at least 4" above grade to prevent flooding of the electrical parts due to heavy rains.

## CONDENSATE DRAIN

The air handler should be pitched approximately 1/4" towards the drain in both directions, to facilitate condensate removal. A drain line must be connected to the air handler and pitched away from the unit a minimum of 1/8" per foot to allow the condensate to flow away from the unit. This connection must be in conformance with local plumbing codes. A trap must be installed in the condensate line to ensure free condensate flow. A vertical air vent is sometimes required to avoid air pockets. (See Figure #6).

The length of the trap depends on the amount of positive or negative pressure on the drain pan. A second trap must not be included.

Air handlers come without condensate overflow sensors installed. A secondary drain pan should at all times be installed below the unit to capture condensate overflow and prevent water damage.

The secondary drain pan should be vibration isolated from the unit and structure. A separate drain line should be used for the auxiliary drain (but no trap is needed in this line).

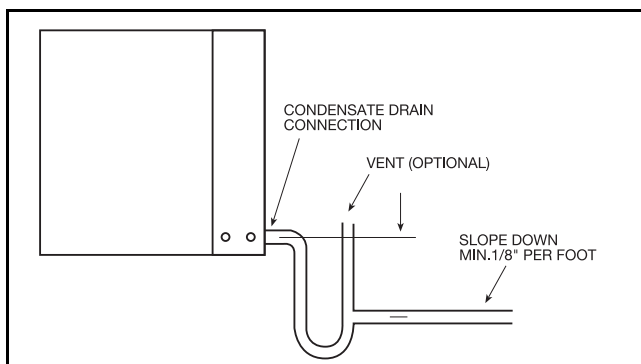

Figure # 6



Units are not internally trapped.

The air handler should be pitched approximately 1/4" towards the drain in both directions, to facilitate condensate removal. (See Figure #7)

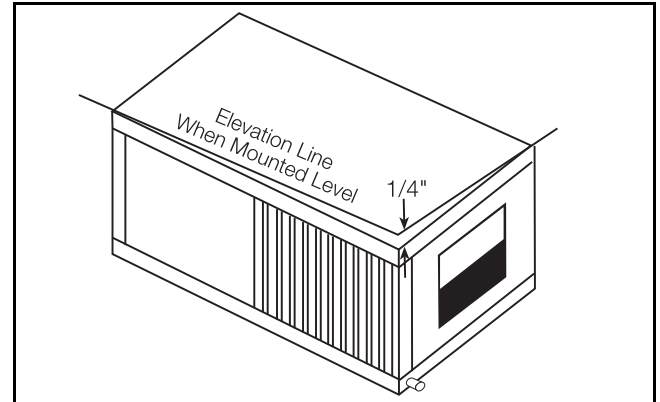

Figure # 7

## Duct Flanges

This series of heat pumps features fold-out return and supply air duct flanges. These fold-out flanges allow the heat pumps to more easily fit through doorways and other tight spaces, and also prevent damage in shipping and handling.

It is recommended that all fold-out flanges be folded-out once the heat pump is installed to insure that return and supply air flow is not obstructed. These flanges can be easily folded using standard or duckbill pliers. Once folded out these flanges can be used to support light ductwork loads.

## DUCT SYSTEM

A flexible connector is recommended for supply and return air duct connections on metal duct systems. All metal ducting should be insulated with a minimum of one inch duct insulation to avoid heat loss or gain and prevent condensate formation during the cooling operation. Application of the unit to uninsulated duct work is not recommended as the system's performance will be adversely affected.

The factory provided air filter must be removed when using a 'filter back return air' grill. The factory filter should be left in place on a free return system.



If the unit will be installed in a new installation which includes new duct work, the installation should be designed using current ASHRAE procedures for duct sizing. If the unit is to be connected to existing ductwork, a check should be made to assure that the duct system has the capacity to handle the air required for the unit application. If the duct system is too small, larger ductwork should be installed. Check for existing leaks and repair.



**CAUTION:** Do not connect discharge ducts directly to the blower outlet.

The duct system and all diffusers should be sized to handle the designed air flow quietly. To maximize sound attenuation of the unit blower, the supply and return air plenums should be insulated. There should be no direct straight air path thru the return air grille into the heat pump.

The return air inlet to the heat pump must have at least one 90 degree turn away from the space return air grille. If air noise or excessive airflow are a problem, the blower speed can be changed to a lower speed to reduce air flow. (Refer to ECM motor interface board section in this manual and blower tables.)

## ELECTRICAL



**WARNING:** Always disconnect power to the unit before servicing to prevent injury or death due to electrical shock or contact with moving parts.

### - High Voltage

All field installed wiring must comply with the National Electric Code as well as all applicable local codes. Refer to the unit electrical data on the unit name plate for wire and branch circuit protection sizing. Supply power voltage and phasing should match the required voltage and phasing shown on the unit name plate. Operating the unit below the minimum voltage, above the maximum voltage or with incorrect phasing can result in poor system performance or damage to the unit. All field wiring should be installed by qualified and trained personnel. Refer to the unit wiring diagram for field connection requirements.



All power connections must be properly torqued to avoid the risk of overheating.

Power wiring to the unit should be enclosed in flexible conduit to minimize the transmission of vibration from the unit cabinet to the building.

For air handlers with unit mounted disconnect switches, field power should be connected to the marked terminals on the disconnect switch.

### 460 V Models with Constant Air Flow Motors

Heat pumps with the constant airflow motor option require a properly sized neutral wire with the power supply wiring in addition to the three high voltage wires and the ground wire. These units employ a 265 V motor that requires power from one phase of the 460 V supply and the neutral wire.



The power supply ground wire should never be used as a neutral wire.

For models with constant air flow motors and a unit mounted disconnect switch, the power wires and neutral wire should be connected to the appropriate terminals on the disconnect switch and its enclosure. For units without a disconnect switch, power and neutral wires should be connected to a provided 4 pole terminal block in the unit electrical box.

### Transformer Settings for 208/230 V Units

As factory built, all 208/230 V units are wired for 230 V operation unless the wire for 208 V option is ordered. For jobsites with a 208 V power supply, the primary leads on the unit transformer will need to be changed from 230 V to 208 V. Refer to the unit wiring diagram for details.

### - Low Voltage

For heat pumps with constant torque fan motors, all thermostat wiring is connected to a terminal block located in the unit electrical box. For heat pumps with a constant air flow fan motor, thermostat wiring is connected to a removable terminal strip located on the ECM motor control board located in the electrical box. Refer to the unit wiring diagram for connection details.



Never route control wiring through the same conduit as power supply wiring.



The heat pump can be controlled by most commonly available single-stage heat pump thermostats. Thermostats should be located on an interior wall away from supply ducts. Avoid locations subject to direct sunlight, drafts, or external walls. Thermostat wiring should be 18 AWG. Refer to the installation instructions for the thermostat for further details.

**i** Exceptionally long runs of thermostat wire should be avoided to prevent voltage drops in the control circuit.

These units are supplied with a 50 VA control transformer as standard. The VA capacity of the transformer should be considered when connecting low voltage accessories to the heat pump such as thermostats or solenoid valves.

**!** Exceeding the transformer capacity can result in low control voltage, erratic unit operation or damage to the heat pump.

**ECM Interface Board (Option)**

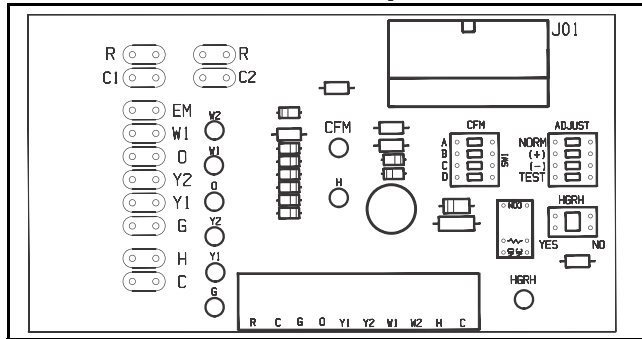

Figure # 8

**Electronic Thermostat Installation**

Position the thermostat subbase against the wall so that it is level and the thermostat wires protrude through the middle of the subbase. Mark the position of the subbase mounting holes and

drill holes with a 3/16-inch bit. Install supplied anchors and secure base to the wall. Thermostat wire must be 8-conductor, 18-AWG wire. Strip the wires back 1/4-inch (longer strip lengths may cause shorts) and insert the thermostat wires into the connector as shown. Tighten the screws to ensure secure connections. The thermostat has the same type connectors, requiring the same wiring. See instructions in the thermostat for detailed installation and operation information.

**i** When using a 2-cool, 3-heat thermostat both the W1 & W2 on the Heat Pump and W2 & EM on the thermostat must be connected together via a jumper. (See Figure#9)

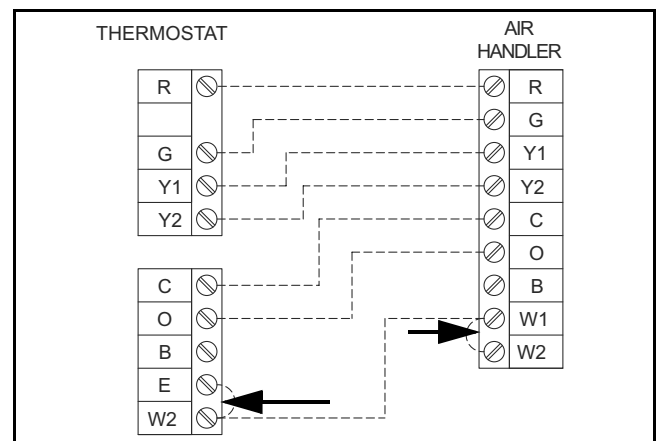

Figure # 9

**i** Air Handlers are equipped with detachable Thermostat connectors. These connectors are located in different locations based on the blower motor that is installed in the unit. For the constant air flow motor, the three detachable thermostat connectors are located on the ECM Interface board.

Figure 10: Low Voltage Connection Points

Function	From Thermostat	To Air Handler	From Air Handler	To Condensing Section
24 VAC Common	C	C	C	C
24 VAC Power	R	R	R	R
Fan Operation	G	G	-	-
Reversing Valve (2)	O	O	O	O
Compressor 1st Stage	Y1	Y1	Y1	Y1
Alarm Output (From UPM)	L /ALR	Splice	-	ALR (UPM)
Emergency Heat (3)	W2/E	W2	-	-

**Table Notes:**

**1)** If LED enunciator is utilized connect 'ALR' terminal on the UPM board to 'L' on the thermostat sub base. The wiring may be spliced in the air handling unit. The 'ALR' output is hot (R) so check thermostat instruction manual to ensure compatibility.

**2)** 'O' – reversing valve is energized in the cooling mode. Fail safe is to heating.

**3)** Utilized when electric strip heater package present.

## Thermostat Connections

The thermostat connections and their functions are as follows:

Y2	Second Stage Compressor Operation
Y1	First Stage Compressor Operation
G	Fan
O	Reversing Valve (energized in cooling)
W1	Auxiliary Electric Heat (runs in conjunction with compressor)
EM/W2	Emergency Heat (electric heat only)
NC	Transformer 24 VAC Common (extra connection)
C1	Transformer 24 VAC Common (primary connection)
R	Transformer 24 VAC Hot
HUM	Dehumidification Mode

If the unit is being connected to a thermostat with a malfunction light, this connection is made at the unit alarm output.



If the thermostat is provided with a malfunction light powered off of the common (C) side of the transformer, a jumper between "R" and "COM" terminal of "ALR" contacts must be made.



If the thermostat is provided with a malfunction light powered off of the hot (R) side of the transformer, then the thermostat malfunction light connection should be connected directly to the (ALR) contact on the unit's UPM board. A jumper between "C" and "COM" terminal of "ALR" contacts must be made.

The thermostat wiring connections are made at the air handling section.

It is recommended to use 18 gauge 7 wire solid copper thermostat conductive cable to wire from the condensing section terminal strip to the air handler terminal strip. Typical wiring diagrams are shown for the air handler at the end of this manual.

## OPTIONS

### Unit Mounted Non-Fused Disconnect Switch

The unit can be supplied with an optional unit mounted disconnect switch mounted to the electrical corner post of the unit.

Field electrical wiring is connected to the switch and the switch then routes power to the air handler electrical box. When the switch is in the "OFF" position, the electrical box is completely de-energized.

### REFRIGERANT LINES

The installation of the copper refrigerant tubing must be done with care to obtain reliable, trouble free operation. This installation should only be performed by qualified refrigeration service and installation personnel.

Refrigerant lines should be routed and supported so as to prevent the transmission of vibrations into the building structure. Experience and good design practice dictate 75 feet as the maximum practical length for interconnecting refrigerant lines in split system heat pumps without special considerations. Beyond 75 feet, system losses become substantial and the total refrigerant charge required can compromise the reliability and design life of the equipment.

Refrigerant lines should be sized in accordance with the General Line Sizing Table in the following instructions. Copper tubing should be clean and free of moisture and dirt or debris. The suction and liquid lines MUST be insulated with at least 3/8" wall, closed-cell foam insulation or the equivalent. Avoid kinking or distorting the tubes – a restricted line set will hurt unit performance.

Therefore, any damaged areas should be cut out and replaced.

Some points to consider are:

- Pressure drop (friction losses) in refrigerant suction lines reduces system capacity and increases power consumption by as much as 2% or more, depending on the line length, number of bends, etc. Pressure drop in liquid lines affects system performance to a lesser degree, provided that a solid column of liquid (no flash gas) is being delivered to the refrigerant metering device, and that the liquid pressure at the refrigerant metering device is sufficient to produce the required refrigerant flow.
- Oil is continually being circulated with the refrigerant so oil return to the compressor is always a consideration in line sizing. Suction lines on split system heat pumps are also hot gas lines in the heating mode, but are treated as suction lines for sizing purposes. If the recommended suction lines sizes are used, there should be no problem with oil return.
- Vertical lines should be kept to a minimum. Vertical liquid lines will have a vertical liquid lift in either heating or cooling, and the weight of the liquid head is added to the friction loss to arrive at the total line pressure drop.

**Linear vs Equivalent Line Length**

Linear Line Length - is the actual measured length of the line including bends. This is used to calculate the additional refrigerant charge that must be added to the system. (See Line Sizing Table and examples)

Equivalent Line Length - is the combination of the actual length of all the straight runs and the equivalent length of all bends valves and fittings in a particular line. The equivalent length of a bend, valve or fitting is equal to the length of a straight tube of the same diameter having the same pressure drop as the particular valve or fitting. The ASHRAE Fundamentals Handbook provides tables for determining the equivalent length of various bends, valves and fittings.

**Connecting Refrigerant Lines**

- Use only ACR grade copper tubing and keep ends sealed until joints are made.
- For best performance, select routing of refrigerant lines for minimum distance and least number of bends.
- Size lines in accordance with the Refrigerant Charge, General Line Sizing and Capacity Multiplier Table.

- When possible, bleed Nitrogen through the lines at 2-3 psi while brazing to prevent oxidizing the inside of the refrigerant piping.
- Condensing sections are shipped with a factory charge so the service valves should not be opened until the line set has been leak tested, purged, and evacuated.
- Cut crimped ends off the air handler suction and liquid lines. Connect and braze lines to the air handler. Be sure to use a very wet rag heat sink on the line to protect the TXV bulb further down.



The air handler is factory supplied with a holding charge of dry nitrogen.

- Condensing sections come with a filter drier (loose) inside the cabinet that must be installed in the liquid line of the line set (choose some place relatively handy in case it needs to be replaced in the future). Additional charge for the filter drier will need to be added according to the tables.
- Connect and braze lines to service valves on the condensing section.



**WARNING:** Always wrap the body of the service valve with a wet towel or apply some other form of heat sink prior to brazing and direct flame away from the valve body. Failure to do so will result in damage to the valve. Valve body temperature must remain below 250°F to protect the internal rubber “O” rings and seals.

**Figure 11: Service Valve Connections**

Unit Size	Line Type	Valve Conn. Size	Allen Wrench Size
LV018-048	Suction	3/4	5/16
LV060-070	Suction	7/8	5/16
All sizes	Liquid	3/8	3/16

Pressurize the refrigerant line set and air handler to 150 psi with dry nitrogen through the Schrader ports provided on the self service valves. Check line set and unit connections for leaks. Once system integrity is verified, evacuate line set and air handler with a good vacuum pump to at least 500 microns and hold for a half hour.



Pump down must never be used with heat pumps.



**DANGER:** High pressure refrigerant gas and liquid is present in the unit. Liquid refrigerant can cause severe burns to exposed skin areas. Wear safety glasses to protect the eyes. Liquid refrigerant in contact with the eyes could cause loss of sight.

Open both service valves in the condensing section by turning the valve stops located at the top of each valve counter-clockwise with an Allen wrench. Make sure that both valves are fully open.

#### THINGS TO REMEMBER:

- If the calculated Equivalent Line Length falls between the lengths shown on the line sizing chart, use tubing sized for the next longer length.
- Maximum Linear (actual) liquid line length without a suction line accumulator is 75 feet.
- A liquid line filter drier is required, it must be of the bidirectional type only and approved for the refrigerant type utilized.
- Suction line size must be based on the line sizing chart.
- Horizontal suction line runs should be pitched slightly toward the compressor to provide free drainage and aid oil return. Do not exceed the largest diameter given in the tables on horizontal runs.
- When brazing always bleed dry nitrogen through refrigerant tubing to displace air and prevent oxidation.
- Air handler is pre-charged in the factory with nitrogen gas. Cut air handler piping with care.



**DANGER:** Always check refrigerant type on the unit data plate before servicing. Do not use R-22 manifold gauges on R-410A units. Doing so could result in severe injury.

## CHARGING THE SYSTEM

### Pre-charge adjustment

The condensing section is shipped with a factory pre-charge and will need to be adjusted to match the specific diameter and length of the liquid line in the line set and the filter drier used. See Line Sizing Table and examples. After adjusting the initial pre-charge, the system will need to be operated and superheat and sub-cooling checked in order to dial in the exact amount of charge needed. If the liquid line is exactly 25 feet and the same diameter as shown in the Line Sizing Table, you can go straight to the final charge adjustment.

**Figure 12: Refrigerant Charge, Line Sizing and Capacity Multiplier<sup>1</sup>**

SYSTEM MODEL	Factory R410A Charge (Oz) <sup>2</sup>	Refrigerant Line O.D. Size (Based on Equivalent Line Length) <sup>3</sup>								Suct. Line Riser Max. <sup>4</sup>
		25 FT. <sup>2</sup>		35 FT.		50 FT.		75 FT		
		LIQ.	SUC.	LIQ.	SUC.	LIQ.	SUC.	LIQ.	SUC.	
LV018	40	3/8	3/4	3/8	3/4	3/8	3/4	3/8	3/4	5/8
LV024	44	3/8	3/4	3/8	3/4	3/8	3/4	3/8	7/8	5/8
LV030	52	3/8	3/4	3/8	3/4	3/8	3/4	3/8	7/8	3/4
LV036	61	3/8	3/4	3/8	3/4	3/8	7/8	3/8	7/8	3/4
LV042	58	3/8	3/4	3/8	3/4	3/8	7/8	1/2	7/8	7/8
LV048	59	3/8	3/4	3/8	7/8	3/8	7/8	1/2	1-1/8	7/8
LV060	93	3/8	7/8	1/2	7/8	1/2	1-1/8	1/2	1-1/8	7/8
LV070	90	3/8	7/8	1/2	1-1/8	1/2	1-1/8	1/2	1-1/8	7/8
CAPACITY MULTIPLIER		1.00		.995		0.990		0.980		

**Example 1:**

Model LV018 with 50ft of equivalent length of 3/8" O.D Liquid Line and factory supplied filter drier. Total system charge = Factory charge +/- adjustment for larger liquid line diameter and additional liquid line length + filter drier adjustment. Total System Charge = 40 oz - (25ft x .60 oz/ft) + (50ft x .60 oz/ft) + 6 oz = 61 oz. Add 21 oz of R410A refrigerant. After adding estimated additional charge, adjust final charge according to subcooling and superheat measurements. See section on charging according to subcooling and superheat.

**Example 2:**

Model LV036 with 45ft of equivalent length of 3/8" O.D Liquid Line and factory supplied filter drier. Estimated Total System Charge = Factory charge +/- liquid line length adjustment + filter drier adjustment. Estimated Total System Charge = 61 oz + ([45ft - 25ft] x .60 oz/ft) + 6 oz = 79 oz. Estimate an additional 18 oz of R410A refrigerant is required. After adding estimated additional charge, adjust final charge according to subcooling and superheat measurements. See section on charging according to subcooling and superheat.

**Example 3:**

Model LV060 with 35ft of equivalent length of 1/2" O.D Liquid Line and factory supplied filter drier. Total system charge = Factory charge - (25ft x 0.6 oz/ft) + (35ft x 1.15 oz/ft) + filter drier adjustment. Total System Charge = 93 oz - 15 + 40 + 9 oz = 127 oz. Add 34 oz of R410A refrigerant. After adding estimated additional charge, adjust final charge according to subcooling and superheat measurements. See section on charging according to subcooling and superheat.

**Notes:**

- Liquid and suction line sizes should be sized according to table, not according to king valve connection size.
- Factory Charge is based on 25 ft of lineset with lineset diameter according to table. Charge adjustments will need to be made for linesets of differing length and/or diameters. Additional charge must also be added for factory supplied filter drier. All charge rates MUST ALWAYS be confirmed and adjusted if necessary by subcooling and superheat measurements (even with a 25 ft lineset and default factory charge). See section on charging according to subcooling and superheat.
- Next diameter size up should be used if equivalent length is longer than shown (75 ft is max)
- Suction line max riser diameter is typically sized to meet minimum of 1,250 FPM refrigerant velocity for proper oil return.
- With 1/2" liquid lines it is recommended to place units as close as practical (minimizing the increased refrigerant volume imposed by the larger line) for maximum compressor life.

**Figure 13: Liquid Line Charge Per Linear Foot**

	Liquid line Size, O.D.				
	1/4	5/16	3/8	1/2	5/8
R410A oz per foot	.25	.44	.60	1.15	1.95

**Figure 14: Additional Charge for factory supplied Filter Drier**

MODEL	Filter Drier Description	Charge – Filter Drier oz
LV018	Filter Drier, BiFlow, R410A, 8 cu in, 3/8 ODF	6
LV024	Filter Drier, BiFlow, R410A, 8 cu in, 3/8 ODF	6
LV030	Filter Drier, BiFlow, R410A, 8 cu in, 3/8 ODF	6
LV036	Filter Drier, BiFlow, R410A, 8 cu in, 3/8 ODF	6
LV042	Filter Drier, BiFlow, R410A, 8 cu in, 3/8 ODF	6
LV048	Filter Drier, BiFlow, R410A, 16 cu in, 5/8 ODF	9
LV060	Filter Drier, BiFlow, R410A, 16 cu in, 5/8 ODF	9
LV070	Filter Drier, BiFlow, R410A, 16 cu in, 5/8 ODF	9

**Notes:**

1. All units require a bi-flow filter drier. Filter drier must be UL listed for R410A with a maximum working pressure of 680 psi. Substitute driers are permissible assuming drier meets these specifications.
2. Final Charge must be adjusted for filter drier - refer to table for charge adjustment.

**Final charge adjustment**

The final charge should be adjusted to so that the unit is operating within the Operating Temperatures and Pressures (see table) and within the sub-cooling and superheat values specified. The unit should come close to the nominal sub-cooling and superheat value with reasonable operating conditions - operating in the middle of the operating range. Adjust the charge until the unit performs to the specifications. The best way is to monitor and adjust the charge in cooling mode first and then check the charge in heating mode. Then if the charge was adjusted in heating, the unit charge and operation should be checked again in cooling mode – to prevent over / under charging.

**Figure 15: Superheat & Sub-Cooling**

Mode	Superheat	Sub-cooling
Heating	9 ±4	11 ±8
Cooling	13 ±6	13 ±6

Check both sub-cooling and superheat before making an adjustment to the charge. In general, if subcooling is low and superheat is high, more charge may be needed. If sub-cooling is high and superheat is low, charge may need to be removed.

The entering water temperature (EWT) has an impact on the sub-cooling and superheat. In cooling with a low EWT - expect the sub-cooling to be normal, while the superheat will be at the high end of the range (whereas with a high EWT, superheat will be at the low end of the range). In heating with a low EWT - expect the sub-cooling to be at the low end of the range, superheat will be normal.

**Determining Sub-Cooling**

1. Determine the liquid line pressure (by attaching the refrigerant gauge to the Schrader connection on the liquid line service valve – the liquid line is the small line).
2. Convert the pressure obtained in Step 1 to the saturation temperature (by using the R-410A Pressure/ Temperature Conversion Chart).
3. Measure the liquid line temperature (the small line) just outside of the condenser cabinet.
4. Subtract the temperature found in step 3 from the temperature found in step 2 – this will be the sub-cooling (this is the total degrees below the saturation temperature)

### Determining Superheat

1. Measure the suction line temperature (near where the expansion valve bulb is clamped).
2. Determine the suction pressure (by attaching the refrigeration gauge to the Schrader valve on the suction side of the compressor).
3. Convert the pressure obtained in Step 2 to the saturation temperature (by using the R-410A Pressure/Temperature Conversion Chart).
4. Subtract the temperature obtained in Step 3 from the temperature found in Step 1. The difference is the amount of superheat for the unit (this is the total degrees above the saturation temperature).

**Figure 16: Pressure to Saturated Temperature - Conversion Chart for R410A**

PRES-SURE (PSIG)	TEMP (°F)	PRES-SURE (PSIG)	TEMP (°F)	PRES-SURE (PSIG)	TEMP (°F)	PRES-SURE (PSIG)	TEMP (°F)	PRES-SURE (PSIG)	TEMP (°F)
50	2	160	56	270	89	380	113	490	133
52	3	162	57	272	89	382	114	492	133
54	5	164	58	274	90	384	114	494	133
56	6	166	58	276	90	386	114	496	134
58	7	168	59	278	91	388	115	498	134
60	9	170	60	280	91	390	115	500	134
62	10	172	61	282	92	392	116	502	135
64	11	174	61	284	92	394	116	504	135
66	13	176	62	286	93	396	116	506	135
68	14	178	63	288	93	398	117	508	136
70	15	180	63	290	94	400	117	510	136
72	16	182	64	292	94	402	117	512	136
74	18	184	65	294	95	404	118	514	136
76	19	186	65	296	95	406	118	516	137
78	20	188	66	298	96	408	119	518	137
80	21	190	66	300	96	410	119	520	137
82	22	192	67	302	97	412	119	522	138
84	23	194	68	304	97	414	120	524	138
86	24	196	68	306	98	416	120	526	138
88	25	198	69	308	98	418	120	528	139
90	26	200	70	310	98	420	121	530	139
92	27	202	70	312	99	422	121	532	139
94	29	204	71	314	99	424	121	534	140
96	30	206	71	316	100	426	122	536	140
98	31	208	72	318	100	428	122	538	140
100	31	210	73	320	101	430	123	540	140
102	32	212	73	322	101	432	123	544	141
104	33	214	74	324	102	434	123	548	142



**Figure 16: Pressure to Saturated Temperature - Conversion Chart for R410A (Continued)**

PRES-SURE (PSIG)	TEMP (°F)	PRES-SURE (PSIG)	TEMP (°F)	PRES-SURE (PSIG)	TEMP (°F)	PRES-SURE (PSIG)	TEMP (°F)	PRES-SURE (PSIG)	TEMP (°F)
106	34	216	74	326	102	436	124	552	142
108	35	218	75	328	102	438	124	556	143
110	36	220	76	330	103	440	124	560	143
112	37	222	76	332	103	442	125	564	144
114	38	224	77	334	104	444	125	568	145
116	39	226	77	336	104	446	125	572	145
118	40	228	78	338	105	448	126	576	146
120	41	230	78	340	105	450	126	580	146
122	41	232	79	342	105	452	126	584	147
124	42	234	80	344	106	454	127	588	147
126	43	236	80	346	106	456	127	592	148
128	44	238	81	348	107	458	127	596	148
130	45	240	81	350	107	460	128	600	149
132	46	242	82	352	108	462	128	604	150
134	46	244	82	354	108	464	128	608	150
136	47	246	83	356	108	466	129	612	151
138	48	248	83	358	109	468	129	616	151
140	49	250	84	360	109	470	129	620	152
142	50	252	84	362	110	472	130	624	152
144	50	254	85	364	110	474	130	628	153
146	51	256	85	366	110	476	130	632	153
148	52	258	86	368	111	478	131	636	154
150	53	260	86	370	111	480	131	640	155
152	53	262	87	372	112	482	131	644	155
154	54	264	87	374	112	484	132	648	156
156	55	266	88	376	112	486	132	652	156
158	56	268	88	378	113	488	132	656	157

## SEQUENCE OF OPERATION

The heat pump is designed to be controlled by a standard 1 heat / 1 cool heat pump thermostat. The heat pump control circuit operates on 24 VAC control voltage regardless of the unit supply voltage.

Fan operation is controlled by the “G” terminal on the heat pump thermostat terminal block. When “G” is energized the unit fan motor will start operating. For heat pumps with constant torque ECM motors, the fan will ramp up to 100% air flow over a 30 second period. For heat pumps with constant air flow ECM motors the fan will ramp up to 70% air flow over a 30 second period if there is no call for compressor operation (“Y”). If there is a call for compressor operation along with a call for fan operation, then the fan will ramp to 100% air flow.

Compressor operation is controlled by the “Y” terminal on the heat pump thermostat terminal block. When “Y” is energized, a signal to start the compressor is sent to the Unit Protection Module (UPM). The UPM checks a number of safety features before then starting the compressor. If any of the safety features connected to the UPM is in a fault condition, the UPM will not start the compressor and will flash a fault code on the red status LED indicating the nature of the fault.

Additionally the UPM will delay compressor operation randomly on initial start up (random start delay) and will prevent the compressor from restarting with less than 5 minutes of off time (anti short cycle delay). Once all faults are cleared and the time delays are satisfied, the UPM will energize the compressor. The compressor will operate as long as the thermostat calls for “Y” and there are no faults. Refer to the troubleshooting chart for fault diagnostics.

## Cooling and Heating Modes

The heat pump operates in cooling with the reversing valve energized. When the “O” terminal is energized, the heat pump will be in the cooling mode, however, will not be actively cooling until the “Y” and “G” terminals are also energized. If the “Y” and “G” terminals are energized without the “O” terminal, then the heat pump will operate in the heating mode.

## Constant Torque Motors (ECM)

The LV split comes standard with a constant torque electronically commutated brushless DC motor (ECM) motor. These motors feature up to 90% thermal efficiency combined with a flatter fan curve than a PSC motor and simple operation. These motors are provided with 5 speed taps to allow for a wide range of air flow and external static options. To change a speed tap follow the instructions below:

1. Disconnect power to the heat pump.
2. Remove the blower access panel.
3. Remove the speed tap wire from the terminal it is currently connected to and connect it to the terminal desired.

Refer to the constant torque motor performance tables for heat pump blower performance with the constant torque motor option.

**Table 1: Constant Torque Blower Motor Data**

Model	Tap #	Rated Airflow												
			0.10	0.20	0.30	0.40	0.50	0.60	0.70	0.80	0.90	1.00	1.10	1.20
LV-018	1		630	590	560	530	490	-	-	-	-	-	-	-
	2	650	720	700	670	630	600	560	-	-	-	-	-	-
	3		790	770	750	710	670	620	560	-	-	-	-	-
	4		910	890	850	810	740	670	590	520	-	-	-	-
	5		1010	970	920	860	810	750	660	530	-	-	-	-
LV-024	1		650	610	580	560	520	-	-	-	-	-	-	-
	2		740	720	690	660	620	570	-	-	-	-	-	-
	3		850	830	800	770	730	690	630	-	-	-	-	-
	4	850	950	920	890	870	840	820	770	650	-	-	-	-
	5		1160	1110	1050	990	920	800	670	560	-	-	-	-
LV-030	1		620	600	570	540	490	-	-	-	-	-	-	-
	2		730	710	670	640	610	550	-	-	-	-	-	-
	3		820	790	760	740	710	670	630	-	-	-	-	-
	4		940	910	880	850	800	740	660	-	-	-	-	-
	5	950	1070	1010	950	900	840	760	670	-	-	-	-	-
LV-036	1		1120	1090	1055	1030	1000	-	-	-	-	-	-	-
	2		1260	1230	1200	1170	1140	1080	-	-	-	-	-	-
	3	1200	1330	1290	1250	1210	1170	1100	1030	-	-	-	-	-
	4		1400	1360	1310	1250	1190	1120	1040	960	-	-	-	-
	5		1470	1420	1360	1290	1220	1140	1050	970	890	-	-	-
LV-042	1		1270	1250	1230	1210	-	-	-	-	-	-	-	-
	2	1400	1440	1420	1410	1410	1400	1380	1340	-	-	-	-	-
	3		1540	1530	1510	1500	1490	1470	1430	1350	-	-	-	-
	4		1650	1630	1610	1600	1580	1530	1460	1360	1240	-	-	-
	5		1730	1720	1700	1670	1620	1570	1490	1380	1260	1100	-	-
LV-048	1		1390	1370	1350	1320	-	-	-	-	-	-	-	-
	2		1600	1580	1550	1530	1510	-	-	-	-	-	-	-
	3	1600	1730	1700	1670	1650	1630	1600	1580	1540	-	-	-	-
	4		1830	1810	1780	1760	1740	1710	1670	1600	1520	-	-	-
	5		1930	1910	1880	1860	1830	1780	1720	1640	1540	1420	-	-
LV-060	1		1900	1880	1860	1820	-	-	-	-	-	-	-	-
	2		2000	1970	1950	1920	1890	1860	-	-	-	-	-	-
	3	2000	2110	2090	2060	2030	2010	1970	1940	1910	1880	-	-	-
	4		2220	2200	2170	2140	2110	2080	2050	2060	2050	2000	1920	-
	5		2340	2320	2290	2260	2230	2210	2180	2150	2110	2070	2000	1930
LV-070	1		2050	2010	1970	1930	-	-	-	-	-	-	-	-
	2		2150	2120	2080	2030	1990	1960	-	-	-	-	-	-
	3	2100	2270	2230	2200	2160	2120	2080	2040	2010	1980	-	-	-
	4		2390	2350	2320	2280	2250	2200	2160	2130	2100	2070	2030	-
	5		2520	2480	2450	2420	2380	2330	2290	2260	2220	2170	2100	2020

## Constant Airflow Motors (ECM)

For installations where constant air delivery is critical or where external static pressure drop can vary greatly (such as with high MERV value filters) the LV is offered with a constant air flow ECM motor option. This option provides ECM motor efficiency combined with a constant air delivery across a wide range of external static pressures. These motors dynamically adjust their power output to precisely match the desired air flow on a pre-programmed fan curve. Additionally these motors feature:

1. A low CFM ventilation feature that circulates air at 70% of full load when fan only is called.
2. A passive dehumidification mode that reduces air flow during a cooling call when dehumidification is also required – this reduces the sensible heat ratio of the cooling coil and extends cooling run time to more effectively dehumidify. (refer to the ECM Interface Board section of this manual)
3. 3 speed settings per model. Units are factory set to “NORM” but can be field adjusted to “+” to increase CFM by 15% or to “-” to reduce CFM by 15%. (refer to the ECM Interface Board section of this manual)
4. A “TEST” mode that operates the motor at a 70% torque setting. This setting can be used to diagnose programming problems in the motor itself. (refer to the ECM Interface Board section of this manual)
5. A CFM indicator light that provides a blink for each 100 CFM of air delivered (note that this blink code is approximate and should not replace test and balancing).

Refer to the constant air flow motor performance tables for heat pump blower performance with the constant air flow motor option.

### Constant Airflow Motor Option Connection point logic is as follows:

(See Figure #8)

To the left of the thermostat connection block are a row of 2 red and 4 green LED's. These LED's indicate the operating status of the unit. They are labeled as follows:

W2	RED	Emergency Heat On
W1	RED	Auxiliary Heat On
O	GREEN	Reversing Valve Energized, unit is in cooling mode
Y2	GREEN	Second Stage Compressor On
Y1	GREEN	First Stage Compressor On
G	GREEN	Fan On

Just above the connector block is a single red LED labeled CFM that will blink intermittently when the unit is running and may flicker when the unit is off. This LED indicates the air delivery of the blower at any given time. Each blink of the LED represents 100 CFM of air delivery so if the LED blinks 12 times, pauses, blinks 12 times, etc. the blower is delivering 1200 CFM. Refer to the Fan Motor Options section for factory programmed air delivery settings.



*To the right of the thermostat connection block is a green LED labeled HGRH. This indicates that the unit is in dehumidification mode and the blower speed has been decreased.*

Just above and to the right of the thermostat connection block are DIP Switches labeled CFM and ADJUST. The ADJUST set of pins are labeled NORM, (+), (-) and TEST. These units will all be set on the NORM position from the factory, however, airflow can be increased (+) or decreased (-) by 15% from the pre-programmed setting by relocating the dip switch in this section.

The TEST position is used to verify proper motor operation. If a motor problem is suspected, move the ADJ jumper to the TEST position and energize G on the thermostat connection block.

If the motor ramps up to 70% power, then the motor itself is functioning normally. Always remember to replace the jumper to NORM, (+) or (-) after testing and reset the unit thermostat to restore normal operation.

The CFM DIP Switch is used to select the proper program in the ECM motor for the unit. Refer to the blower tables for the proper dip switch positions.



**NOTE:** Always disconnect power before changing dip switch positions on the interface board and reset the unit afterward.

To the left of the red and green status LED's is a row of 1/4" male quick connects. These are used to pass thermostat inputs on to the rest of the control circuit. Remember to always turn off unit power at the circuit breaker before attaching or disconnecting any wiring from these connections to avoid accidental short circuits that can damage unit control components.

**Table 2: Constant Airflow Motor Performance Table**

Model	Fan Speed	Rated Airflow												
			0.10	0.20	0.30	0.40	0.50	0.60	0.70	0.80	0.90	1.00	1.10	1.20
LV-018	B - Low		550	540	540	540	540	540	540	530	520	500	-	-
	B - Normal	650	650	650	650	650	650	650	640	630	610	590	-	-
	B - Hi		750	750	750	750	750	750	740	730	710	690	-	-
LV-024	C - Low		720	720	720	720	720	720	720	700	650	560	-	-
	C - Normal	850	850	850	850	850	850	850	850	850	800	700	-	-
	C - Hi		960	960	960	960	960	960	960	960	880	790	-	-
LV-030	D - Low		810	810	810	810	810	810	810	770	720	650	-	-
	D - Normal	950	950	950	950	950	950	950	950	900	850	780	-	-
	D - Hi		980	980	980	980	980	980	980	950	900	820	-	-
LV-036	A - Low		1020	1020	1020	1020	1020	1020	1000	990	960	930	-	-
	A - Normal	1200	1200	1200	1200	1200	1200	1200	1180	1160	1130	1090	-	-
	A - Hi		1380	1380	1380	1380	1380	1380	1360	1330	1300	1250	-	-
LV-042	B - Low		1190	1190	1190	1190	1190	1190	1190	1190	1190	1190	1190	-
	B - Normal	1400	1400	1400	1400	1400	1400	1400	1400	1400	1400	1400	1400	-
	B - Hi		1630	1630	1630	1630	1630	1630	1630	1630	1630	1630	1630	-
LV-048	A - Low		1340	1340	1340	1340	1340	1340	1340	1340	1340	1340	1340	-
	A - Normal	1600	1600	1600	1600	1600	1600	1600	1600	1600	1600	1600	1600	-
	A - Hi		1810	1810	1810	1810	1810	1810	1810	1810	1810	1810	1810	-
LV-060	A - Low		1700	1700	1700	1700	1700	1700	1700	1700	1700	1690	1690	1680
	A - Normal	2000	2000	2000	2000	2000	2000	2000	2000	2000	2000	1980	1980	1980
	A - Hi		2220	2220	2220	2220	2220	2220	2220	2220	2220	2130	2100	2070
LV-070	B - Low		1870	1870	1870	1870	1870	1870	1870	1870	1870	1870	1870	1870
	B - Normal	2200	2200	2200	2200	2200	2200	2200	2200	2200	2200	2200	2200	2200
	B - Hi		2330	2330	2330	2330	2330	2330	2330	2330	2330	2330	2330	2330

**Notes:**

1. Air flow is 70% of tabulated values during fan only operation.
2. Air flow is 85% of tabulated value during passive dehumidification mode when enabled.

## Constant Torque ECM Blower Motor

**Table 3: Electrical Data Table - Constant Torque ECM Blower Motor**

MODEL	Voltage Code	Motor Voltage/Phase/Hz	Voltage Min/Max	Blower Motor		Main Circuit Amps	Max Fuse/HACR
				FLA	HP		
LV018	1	208-230/1/60	197/253	2.8	0.30	3.5	15
	2	265/1/60	238/292	2.6	0.30	3.3	15
LV024	1	208-230/1/60	197/253	2.8	0.30	3.5	15
	2	265/1/60	238/292	2.6	0.30	3.3	15
	3	208-230/1/60	197/253	2.8	0.30	3.5	15
	4	460/1/60	414/506	2.1	0.50	2.6	15
LV030	1	208-230/1/60	197/253	2.8	0.30	3.5	15
	2	265/1/60	238/292	2.6	0.30	3.3	15
	3	208-230/1/60	197/253	2.8	0.30	3.5	15
	4	460/1/60	414/506	2.1	0.50	2.6	15
LV036	1	208-230/1/60	197/253	4.1	0.5	5.1	15
	2	265/1/60	238/292	3.9	0.5	4.9	15
	3	208-230/1/60	197/253	4.1	0.5	5.1	15
	4	460/1/60	414/506	2.1	0.5	2.6	15
LV042	1	208-230/1/60	197/253	6.0	0.8	7.5	15
	3	208-230/1/60	197/253	6.0	0.8	7.5	15
	4	460/1/60	414/506	4.6	0.8	5.8	15
LV048	1	208-230/1/60	197/253	6.0	0.80	7.5	15
	3	208-230/1/60	197/253	6.0	0.80	7.5	15
	4	460/1/60	414/506	4.6	0.80	5.8	15
LV060	1	208-230/1/60	197/253	7.6	1.00	9.5	15
	3	208-230/1/60	197/253	7.6	1.00	9.5	15
	4	460/1/60	414/506	4.0	1.00	5.0	15
LV070	1	208-230/1/60	197/253	7.6	1.00	9.5	15
	3	208-230/1/60	197/253	7.6	1.00	9.5	15
	4	460/1/60	414/506	4.0	1.00	5.0	15

**Notes:**

- 208/230V units shipped with transformer wired for 230V—for 208V remove orange transformer primary lead and replace with red lead. All blower motors are single phase.
- UNIT POWER SUPPLY: A voltage variation of +/- 10% of nameplate rating is acceptable. Phase imbalance shall not exceed 2%.

## Constant CFM ECM Blower Motor

**Table 4: Electrical Data Table - Constant CFM ECM Blower Motor**

MODEL	Voltage Code	Motor Voltage/Phase/Hz	Voltage Min/Max	Blower Motor		Main Circuit Amps	Max Fuse/HACR
				FLA	HP		
LV018	1	208-230/1/60	197/253	2.8	0.30	3.5	15
	2	265/1/60	238/292	2.6	0.30	3.3	15
LV024	1	208-230/1/60	197/253	2.8	0.30	3.5	15
	2	265/1/60	238/292	2.6	0.30	3.3	15
	3	208-230/1/60	197/253	2.8	0.30	3.5	15
	4	460/1/60	414/506	2.6	0.30	3.3	15
LV030	1	208-230/1/60	197/253	2.8	0.30	3.5	15
	2	265/1/60	238/292	2.6	0.30	3.3	15
	3	208-230/1/60	197/253	2.8	0.30	3.5	15
	4	460/1/60	414/506	2.6	0.30	3.3	15
LV036	1	208-230/1/60	197/253	4.3	0.5	5.4	15
	2	265/1/60	238/292	4.1	0.5	5.1	15
	3	208-230/1/60	197/253	4.3	0.5	5.4	15
	4	460/1/60	414/506	4.1	0.5	5.1	15
LV042	1	208-230/1/60	197/253	6.8	0.8	8.5	15
	3	208-230/1/60	197/253	6.8	0.8	8.5	15
	4	460/1/60	414/506	5.5	0.8	6.9	15
LV048	1	208-230/1/60	197/253	6.8	0.80	8.5	15
	3	208-230/1/60	197/253	6.8	0.80	8.5	15
	4	460/1/60	414/506	5.5	0.80	6.9	15
LV060	1	208-230/1/60	197/253	9.1	1.00	11.4	20
	3	208-230/1/60	197/253	9.1	1.00	11.4	20
	4	460/1/60	414/506	6.9	1.00	8.6	15
LV070	1	208-230/1/60	197/253	9.1	1.00	11.4	20
	3	208-230/1/60	197/253	9.1	1.00	11.4	20
	4	460/1/60	414/506	6.9	1.00	8.6	15

**Notes:**

1. 208/230V units shipped with transformer wired for 230V—for 208V remove orange transformer primary lead and replace with red lead. All blower motors are single phase.
2. UNIT POWER SUPPLY: A voltage variation of +/- 10% of nameplate rating is acceptable. Phase imbalance shall not exceed 2%.



## APPLICATION CONSIDERATIONS

### Well Water Systems

(Figure #17)

In well water applications water pressure must always be maintained in the heat exchanger. This can be accomplished with either a control valve or a bladder type expansion tank. When using a single water well to supply both domestic water and the heat pump, care must be taken to ensure that the well can provide sufficient flow for both. In well water applications a slow closing solenoid valve must be used to prevent water hammer.

Solenoid valves should be connected across Y1 and C1 on the interface board for all constant air flow models. Make sure that the VA draw of the valve does not exceed the contact rating of the thermostat or the remaining VA available for accessories/options from the air handler power supply.

### Cooling Tower/Boiler Systems

(Figure #18)

The cooling tower and boiler water loop temperature should be maintained between 50° F to 110° F to assure adequate cooling and heating performance.

In the cooling mode, heat is rejected from the FHP unit into the water loop. A cooling tower provides evaporative cooling to the loop water thus maintaining a constant supply temperature to the unit. When utilizing open cooling towers, chemical water treatment is mandatory to ensure the water is free from corrosive elements. A secondary heat exchanger (plate frame) between the unit and the open cooling tower may also be used. It is imperative that all air be eliminated from the closed loop side of the heat exchanger to protect against fouling.

In the heating mode, heat is absorbed from the water loop. A boiler can be utilized to maintain the loop at the desired temperature.



**CAUTION:** Water piping exposed to extreme low ambient temperatures is subject to freezing.

Consult the dimensional drawings for piping sizes. Teflon tape sealer should be used when connecting to the unit to protect against leaks and possible heat exchanger fouling. Do not overtighten the connections. Flexible hoses should be used between the unit and the rigid system to avoid damage from vibration. Ball valves should be installed in the supply and return lines for unit isolation and unit water flow balancing. Pressure/temperature ports are recommended in both supply and return lines for system flow balancing. Water flow can be accurately set by measuring the water-to-refrigerant heat exchanger's water side pressure drop. See Operating Temperatures and Pressures for water flow vs. pressure drop information.

No unit should be connected to the supply or return piping until the water system has been completely cleaned and flushed to remove any dirt, piping chips or other foreign material. Supply and return hoses should be connected together during this process to ensure the entire system is properly flushed.

After the cleaning and flushing has taken place the unit may be connected to the water loop and should have all valves wide open.

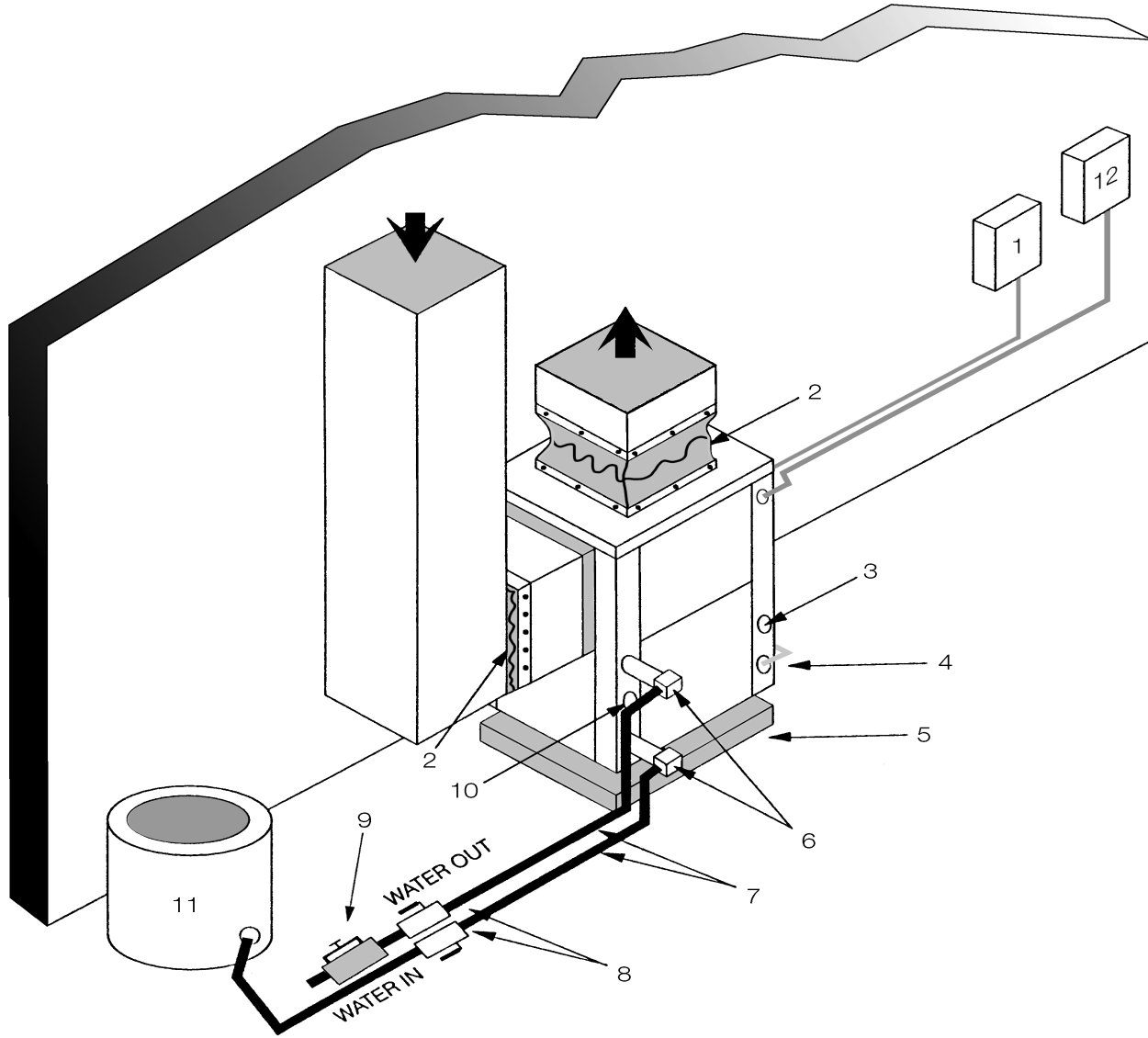
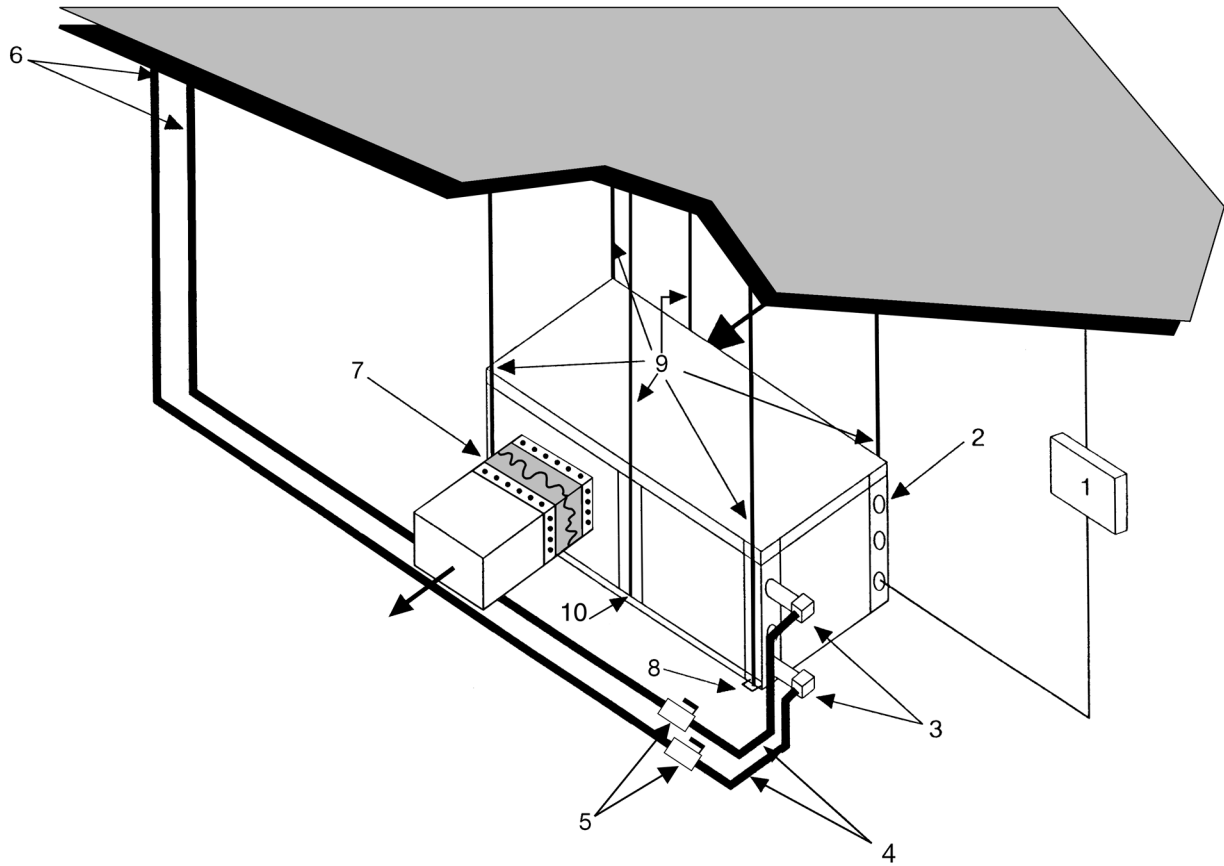

**Figure # 17 Well Water Applications**

- [1] Line Voltage Disconnect (unit)
- [2] Flex Duct Connect
- [3] Low Voltage Control Connection
- [4] Line Voltage Connection
- [5] Vibration Pad
- [6] P/T Ports
- [7] Hose Kits (optional)
- [8] Ball Valves
- [9] Solenoid Valve Slow Closing
- [10] Condensate Drain Connection
- [11] Pressure Tank (optional)



Typical Layout Illustration. See Figure #6 for Condensate Drain Connection



**Figure # 18 Cooling Tower/Boiler Application**

- [1] Line Voltage Disconnect (unit)
- [2] Low Voltage Control Connection
- [3] P/T Plugs (optional)
- [4] Hose Kits (optional)
- [5] Ball Valves
- [6] Supply and Return lines of central system
- [7] Flex Duct Connection
- [8] Hanging Brackets Assembly
- [9] Threaded Rod
- [10] Hanging Bracket Assembly



Typical Layout Illustration. See Figure #6 for Condensate Drain Connection

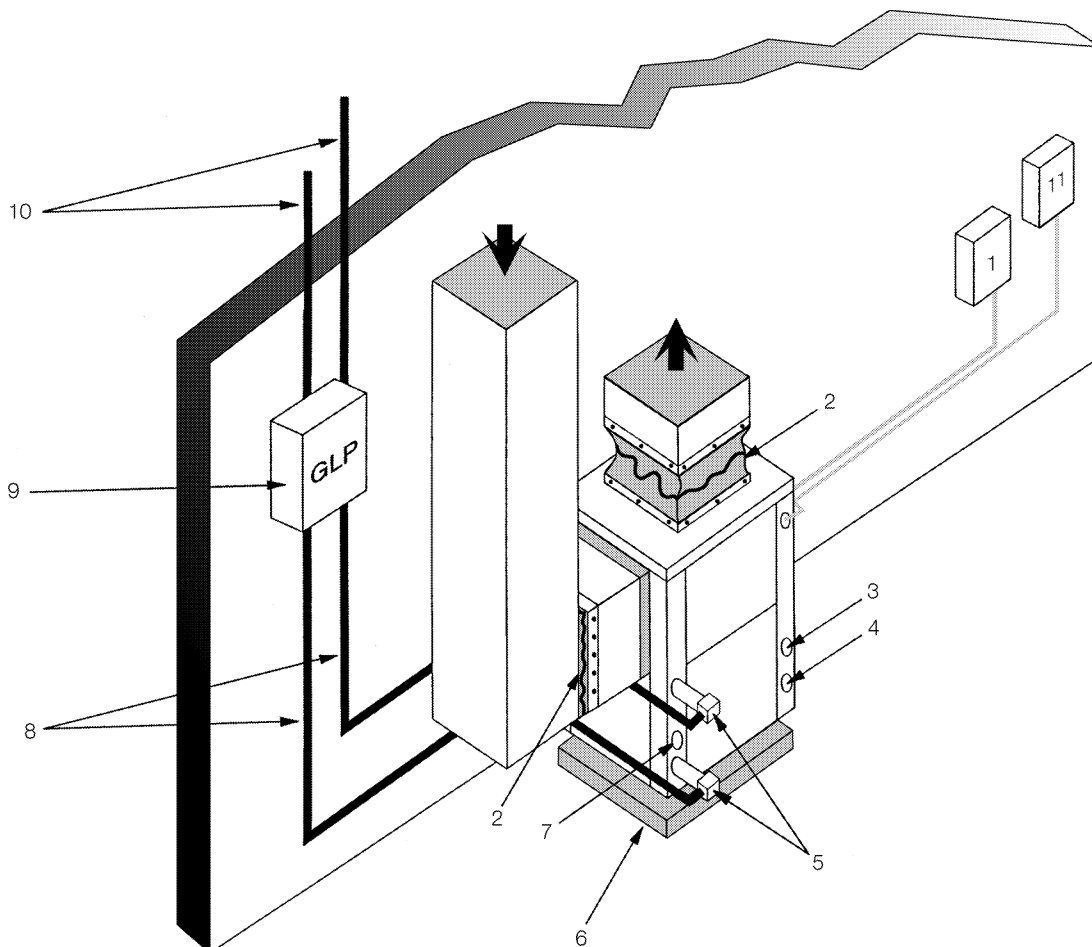

Figure # 19 Geothermal Application

## Geothermal Systems

Each condensing section comes with an insulated water-to-refrigerant heat exchanger making it suitable for geothermal applications. Closed loop and pond applications require specialized design knowledge. No attempt at these installations should be made unless the dealer has received specialized training. Utilizing the Ground Loop Pumping Package (GLP), makes the installation easy. Anti-freeze solutions are utilized when low evaporating conditions are expected to occur. Refer to the GLP installation manuals for more specific instructions.



Typical Layout Illustration. See Figure #6 for Condensate Drain Connection

- [1] Line Voltage Disconnect (unit)
- [2] Flex Duct Connection
- [3] Low Voltage Control Connection
- [4] Line Voltage Connection (unit)
- [5] P/T Ports
- [6] Vibration Pad
- [7] Condensate Drain
- [8] Ground Loop Connection Kit
- [9] Ground Loop Pumping Package (GL001-1 or 002-1)
- [10] Polyethylene with Insulation

## SYSTEM CHECKOUT

After completing the installation, and before energizing the unit, the following system checks should be made:

- Verify that the supply voltage to the heat pump is in accordance with the nameplate ratings.
- Make sure that all electrical connections are tight and secure.
- Check the electrical fusing and wiring for the correct size.



Ensure cabinet and Electrical Box are properly grounded.

- Verify that the low voltage wiring between the thermostat and the unit is correct.
- Verify that the water piping is complete and correct.
- Check that the water flow is correct, and adjust if necessary.
- Check the blower for free rotation, and that it is secured to the shaft.
- Verify that vibration isolation has been provided.
- Unit is serviceable. Be certain that all access panels are secured in place.

Considerations:

1. Always check incoming line voltage power supply and secondary control voltage for adequacy. Transformer primaries are dual tapped for 208 and 230 volts. Connect the appropriate tap to ensure a minimum of 18 volts secondary control voltage. 24 volts is ideal for best operation.
2. Long length thermostat and control wiring leads may create voltage drop. Increased wire gauge or up-sized transformers may be required to ensure minimum secondary voltage supply.
3. The guidelines for wiring between a thermostat and the unit are: 18 GA up to 60 foot, 16 GA up to 100 ft and 14 GA up to 140 ft.
4. Do not apply additional controlled devices to the control circuit power supply without consulting the factory. Doing so may void equipment warranties.
5. Check with all code authorities on requirements involving condensate disposal/over flow protection criteria.

## UNIT START-UP

1. Put the UPM board in “test” mode.
2. Set the thermostat to the highest setting.
3. Set the thermostat system switch to “COOL”, and the fan switch to the “AUTO” position. The reversing valve solenoid should energize. The compressor and fan should not run.
4. Reduce the thermostat setting approximately 5 degrees below the room temperature.
5. Verify the heat pump is operating in the cooling mode.
6. Turn the thermostat system switch to the “OFF” position. The unit should stop running and the reversing valve should de energize.
7. Leave the unit off for approximately (5) minutes to allow for system equalization.
8. Turn the thermostat to the lowest setting.
9. Set the thermostat switch to “HEAT”.
10. Increase the thermostat setting approximately 5 degrees above the room temperature.
11. Verify the heat pump is operating in the heating mode.
12. Set the thermostat to maintain the desired space temperature.
13. Check for vibrations, leaks, etc.

## MAINTENANCE

1. Filter changes or cleanings are required at regular intervals. The time period between filter changes will depend upon type of environment the equipment is used in. In a single family home, that is not under construction, changing or cleaning the filter every 60 days is sufficient. In other applications such as motels, where daily vacuuming produces a large amount of lint, filter changes may need to be as frequent as biweekly.



Equipment should never be used during construction due to likelihood of wall board dust accumulation in the air coil of the equipment which permanently affects the performance and may shorten the life of the equipment.

2. An annual “checkup” is recommended by a licensed refrigeration mechanic. Recording the performance measurements of volts, amps, and water temperature differences (both heating and cooling) is recommended. This data should be compared to the information on the unit’s data plate and the data taken at the original startup of the equipment.
3. Lubrication of the blower motor is not required, however may be performed on some motors to extend motor life. Use **SAE-20** non-detergent electric motor oil.
4. The condensate drain should be checked annually by cleaning and flushing to insure proper drainage.
5. Periodic lockouts almost always are caused by air or water flow problems. The lockout (shutdown) of the unit is a normal protective measure in the design of the equipment. If continual lockouts occur call a mechanic immediately and have them check for: water flow problems, water temperature problems, air flow problems or air temperature problems. Use of the pressure and temperature charts for the unit may be required to properly determine the cause.

**TROUBLESHOOTING**

UNIT TROUBLESHOOTING					
Problem	Mode		Check	Possible Cause	Action
	Cooling	Heating			
<b>No compressor operation but fan runs</b>	X		Is fault LED Blinking 1 time?	High Pressure fault - no or low water flow	Check water valves and/or pumps for proper operation. Check for water coil blockage.
				High Pressure fault - high water temperature	Check water temperature - is it in range?
				High Pressure fault - fouled or scaled water coil	Check for proper flow rate and water temperature, but low water side temp rise in cooling
		X		High Pressure fault - no or low air flow	Check fan motor for proper operation.
					Check air filter
					Inspect air coil for dirt/debris
				High Pressure fault - no or low air flow	Check duct work - are dampers closed or blocked?
	X		Is fault LED Blinking 2 times?	Low Pressure fault - no or low air flow	Check fan motor for proper operation.
					Check air filter
					Inspect air coil for dirt/debris
					Check duct work - are dampers closed or blocked?
				Low Pressure fault - low refrigerant	Check refrigerant pressure with gauge set
				Low Pressure fault - no or low water flow	Check water valves and/or pumps for proper operation. Check for water coil blockage.
	X		75Unit	Check for proper flow rate and water temperature, but low water side temp drop in heating.	
				Low Pressure fault - low refrigerant	Check refrigerant pressure with gauge set
	X	Is fault LED Blinking 3 times?	Freeze fault, water coil - no or low water flow	Check water valves and/or pumps for proper operation. Check for water coil blockage.	
				Freeze fault - low water temperature	Check water temperature - is it below 40° entering? If heat pump is connected to a closed loop with antifreeze check that the "FREEZE 1" resistor on the UPM board has been cut to set the unit to antifreeze mode (see UPM features on pages 15-17).
			Freeze fault - low refrigerant	Check refrigerant pressure with gauge set	



**UNIT TROUBLESHOOTING**

Problem	Mode		Check	Possible Cause	Action
<b>No compressor operation but fan runs</b>	X		Is fault LED Blinking 4 times?	Condensate fault - poor drainage	Check condensate pan for high water level. Check drain line for blockages, double trapping or inadequate trapping.
				Condensate fault - blocked return air	Check condensate pan for high water level. Check air filter and return air duct work for blockage. Check that there is adequate space between the return air opening and walls or other obstructions on free return applications.
	X	X	Is fault LED Blinking 5 times?	Brown out fault - low supply voltage	Check primary voltage - insure it is within the limits listed on the unit data plate.
				Brown out fault - overloaded control circuit	Check control voltage - if it is below 18 V check accessories connected to the unit and insure that they do not exceed the VA draw shown on page 11.
				Brown out fault - bad thermostat connection	Check that thermostat wiring is proper gauge and length, that it is not damaged and that all connections at the thermostat and heat pump are secure.
	X		Is fault LED Blinking 6 times?	Freeze fault, air coil - no or low air flow	Check fan motor for proper operation.
					Check air filter
					Inspect air coil for dirt/debris
					Check duct work - are dampers closed or blocked?
				Freeze fault, air coil - blocked return air	Check that there is adequate space between the return air opening and walls or other obstructions on free return applications.
	Freeze fault, air coil - low refrigerant	Check refrigerant pressure with gauge set.			
	X	X	No fault LED - contactor not energized	Thermostat not calling for compressor operation	Ensure that the thermostat is on and calling for "Y"
				Bad thermostat connection	Check "Y" connection from thermostat. Insure that there is 24 VAC between "Y" and "C".
				Loose wire to contactor coil	Check wiring - insure that there is 24 VAC across the contactor coil.
Burned out contactor coil				Test contactor with 24VAC (between "R" and "C"). Ohm contactor coil - an open circuit indicates a burned coil.	

UNIT TROUBLESHOOTING					
Problem	Mode		Check	Possible Cause	Action
<b>No compressor operation but fan runs</b>	X	X	No fault LED - contactor energized	Open compressor overload	Check for supply voltage at the load side of the contactor. For 3 phase models check phase rotation and voltage at all 3 phases.
				Poor wiring connections	Look for signs of heat on the wiring insulation. Check that all wiring connections are secure and properly torqued.
				Burned out compressor	Does compressor hum when power is applied? If not check the resistance of the compressor windings using the values shown in the compressor characteristics chart. Note that the compressor must be cool (70° F) when checking the windings.
<b>No compressor or fan operation</b>	X	X	Power LED on	Bad thermostat connection / faulty thermostat	Check thermostat and wiring. Check unit terminal block for 24 VAC between "Y" and "C" and "G" and "C".
			Power LED off	Low or no supply power	Insure that the supply voltage to the unit is with in the range shown on the unit data plate.
				Faulty control transformer	Check for 24 VAC between "R" and "C" on the unit terminal block. For 75 and 100 VA transformers, check that the transformer circuit breaker has not tripped. Check low voltage circuit for overload conditons or short circuits before replacing the transformer.
<b>No fan operation - PSC motor</b>	X	X	Fan relay energized	Faulty motor	check supply voltage from the fan relay to the motor. Check that all motor wires are secure. With power off spin the motor shaft - noise, resistance or uneven motion can be signs of motor failure.
			Fan relay not energized	No fan operation signal	Check for 24 VAC across the fan relay coil. Check all wiring connections.
				Bad fan relay	If the relay coil is energized but the relay does not pull in, check the resistance across the relay coil - an open circuit is an indicator of a faulty relay.
<b>No fan operation - constant torque motor</b>	X	X		No fan operation signal	Check for 24 VAC between "G" and "C". Check all wiring connections.
				Loose wiring	Check all wiring connections at motor and control box.
				Faulty motor	Check supply voltage to the motor. Check that all motor wires are secure. With power off spin the motor shaft - noise, resistance or uneven motion can be signs of motor failure.

## UNIT TROUBLESHOOTING

Problem	Mode		Check	Possible Cause	Action
<b>No fan operation - constant airflow motor</b>	X	X		No fan operation signal	Check for 24 VAC between "G" and "C". Check all wiring connections. Make sure that the thermostat connection plug is securely connected.
				Loose wiring	Check all wiring connections at motor and control box. Check that power and control harnesses are securely connected.
				Interface board problems	Make sure that the interface board is not damaged and that all DIP switches are in the proper configuration (refer to the blower performance tables).
				Faulty motor	Check supply voltage to the motor. Check that all motor wires are secure. Move the "TEST" DIP switch to "ON" and the other switches to "OFF" on the "ADJUST" switch block on the interface board - the motor should run at 70% torque when "G" is called. With power off spin the motor shaft - noise, resistance or uneven motion can be signs of motor failure.
<b>Unit not shifting into cooling</b>	X		Reversing valve solenoid energized	Faulty solenoid	Check that the reversing valve solenoid is receiving 24 VAC. If so, check the resistance of the solenoid - an open circuit may indicate a burned out solenoid.
			Reversing valve solenoid not energized	Miswired/faulty thermostat	Check that the reversing valve thermostat wire is connected to the "O" terminal of the thermostat. Check for a contact closure between "O" and "R".
				Loose wire on "O" terminal	Check that the wires from the thermostat to the unit are securely connected and that the wires from the electrical box to the reversing valve are connected.
<b>Excessively cold supply air temperature in cooling or excessively hot supply air temperature in heating</b>	X	X	Reduced air flow	Dirty Filter	Replace filter.
				Fan speed too low	Consult blower performance table and increase fan speed if possible.
				Excessive duct pressure drop	Consult blower performance table and increase fan speed if possible.
<b>Excessively warm supply air temperature in cooling and/or excessively cool air in heating</b>	X	X	Air flow too high	Fan speed setting too high	Consult blower performance table and reduce fan speed if possible.
			High or low water temperature	Inlet water temperature out of range	Check unit capacity vs. water temperature.
			Air leakage	Leaky duct work	Inspect duct work.
			Loss of refrigeration capacity	Low refrigerant	Check refrigerant pressures with gauge set.

UNIT TROUBLESHOOTING					
Problem	Mode		Check	Possible Cause	Action
High humidity	X		Air flow too high	Fan speed setting too high	Consult blower performance table and reduce fan speed if possible.
			Loss of refrigeration capacity	Low refrigerant	Check refrigerant pressures with gauge set.
			Short cycling	Unit oversized	Check unit performance against building load calculations.
				Poor thermostat location	Make sure that thermostat is not located by a supply air duct .
Objectionable noise levels	X	X	Air noise	Poor duct work/grille design	Insure duct work and grilles are properly sized for unit air flow.
				Fan speed setting too high	Consult blower performance table and reduce fan speed if possible.
			Structure bourne noise	Unit not mounted on full vibration pad	Mount unit on a vibration pad (see page 7).
				Unit not connected with flexible conduit, water lines and/or duct work	Install unit in accordance with instructions on pages 6-8.
	Unit cabinet touching wall or other building component	Adjust unit location to avoid unit touching structure.			
	X		Compressor noise	High water temperature or low water flow rate elevating head pressure	Increase water flow rate and/or reduce water temperature if possible.
				Scaled or fouled water coil elevating heat pressure	Clean/descale water coil.
				Low air flow elevating head pressure	Check filter.
	Increase fan speed.				
	X	X	Water hammer	Fast closing valves installed	change valves to slow-close type.

WIRING DIAGRAMS

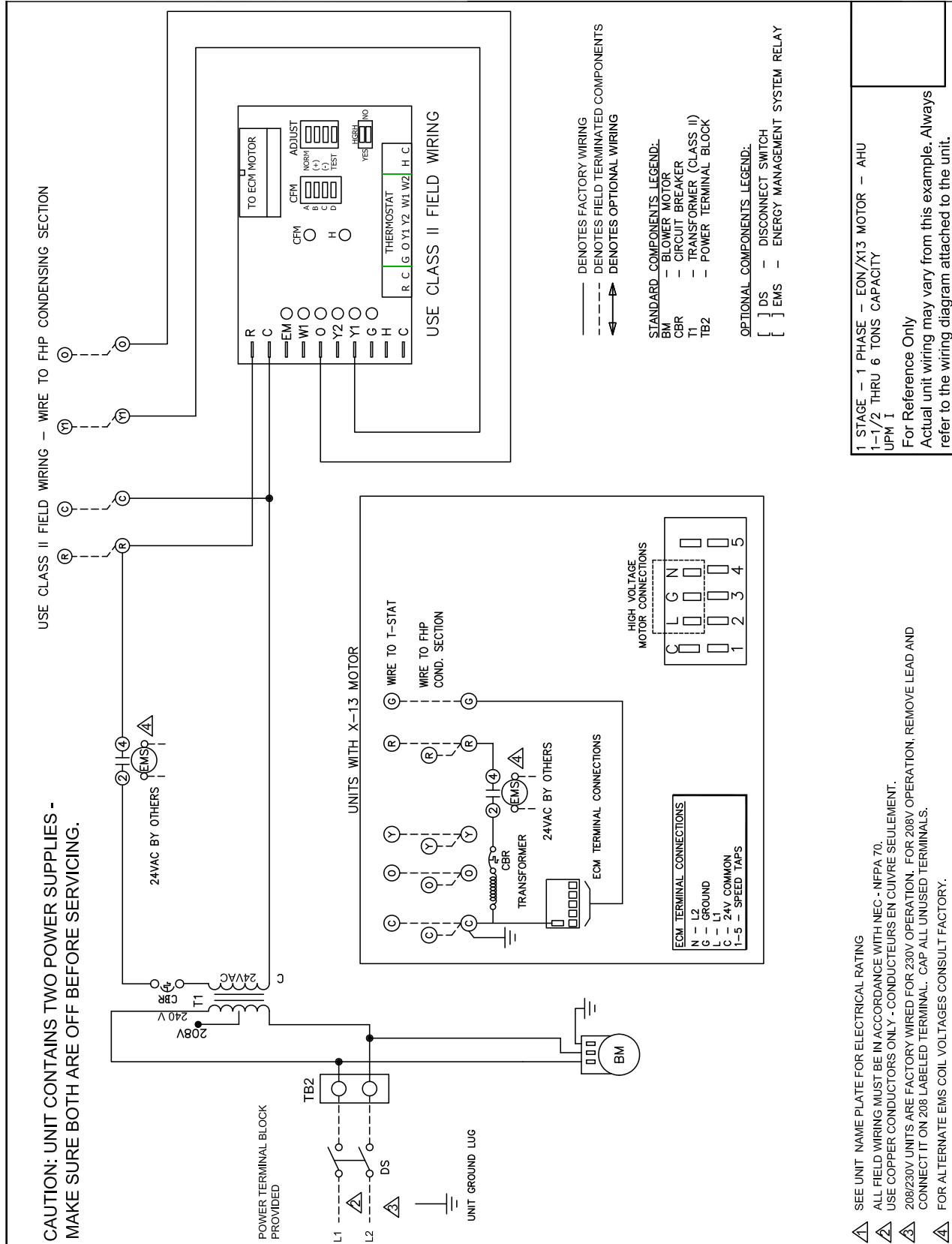

Figure # 20 LV - No Electric Heat Kit

# DIMENSIONAL DRAWINGS

Model	A	B	C	D	E	F	J	K	M	N	P	Q	R	T	Recommended Replacement Nominal Filter Size	
	Width	Depth	Height	Cabinet End to Filter Rack	R/A Duct Width	Cab Front to Filter Rack	Side to Discharge (End)	Discharge Width	Top to Discharge (FLE & FRS)	Discharge Height	End to Discharge (Straight)	Top to Discharge (FRE & FLS)	Filter Rack Height	R/A Duct Flange Height	Condensate Drain Connection	
LV018	22.0	43.0	17.0	1.5	20.15	21.35	5.42	9.13	6.11	9.65	4.92	1.23	16.3	14.5	3/4" FPT	16 x 20 x 1
LV024	22.0	43.0	17.0	1.5	25.0	16.5	5.42	9.13	6.11	9.65	4.92	1.23	16.3	14.5	3/4" FPT	16 x 25 x 1
LV030	22.0	43.0	17.0	1.5	25.0	16.5	5.42	9.13	6.11	9.65	4.92	1.23	16.3	14.5	3/4" FPT	16 x 25 x 1
LV036	22.0	54.5	19.0	1.5	30.15	22.85	6.47	9.13	7.5	10.28	5.97	1.21	18.3	16.5	3/4" FPT	18 x 30 x 1
LV042	22.0	54.5	19.0	1.5	30.15	22.85	5.27	10.45	6.46	11.3	4.77	1.22	18.3	16.5	3/4" FPT	18 x 30 x 1
LV048	25.0	54.5	21.0	1.5	34.6	18.4	7.25	10.45	7.46	11.36	6.75	2.16	20.3	18.5	3/4" FPT	20 x 34.5 x 1
LV060	25.0	54.5	21.0	1.5	34.6	18.4	6.32	11.76	6.81	12.5	5.82	1.68	20.3	18.5	3/4" FPT	20 x 34.5 x 1
LV070	25.0	65.0	21.0	1.5	48.1	15.4	6.32	11.76	6.81	12.5	5.82	1.68	20.3	18.5	3/4" FPT	20 x 24 x 1 (2)

**NOTES:**  
 All dimensions within  $\pm 0.125"$ .  
 All condensate drain connections are 3/4" FPT.  
 Horizontal units can be field converted between end blow and straight through supply air configurations.

Specifications subject to change without notice.  
 1" filter rack extends 1.23" beyond the side of the unit. 2" filter rack extends 2.89" beyond the side of the unit.

The 2" filter rack is 4 sided with a filter access door on each end and can accept either a 1" or 2" filter.

Refrigerant line connections are located directly behind refrigerant line knockouts.

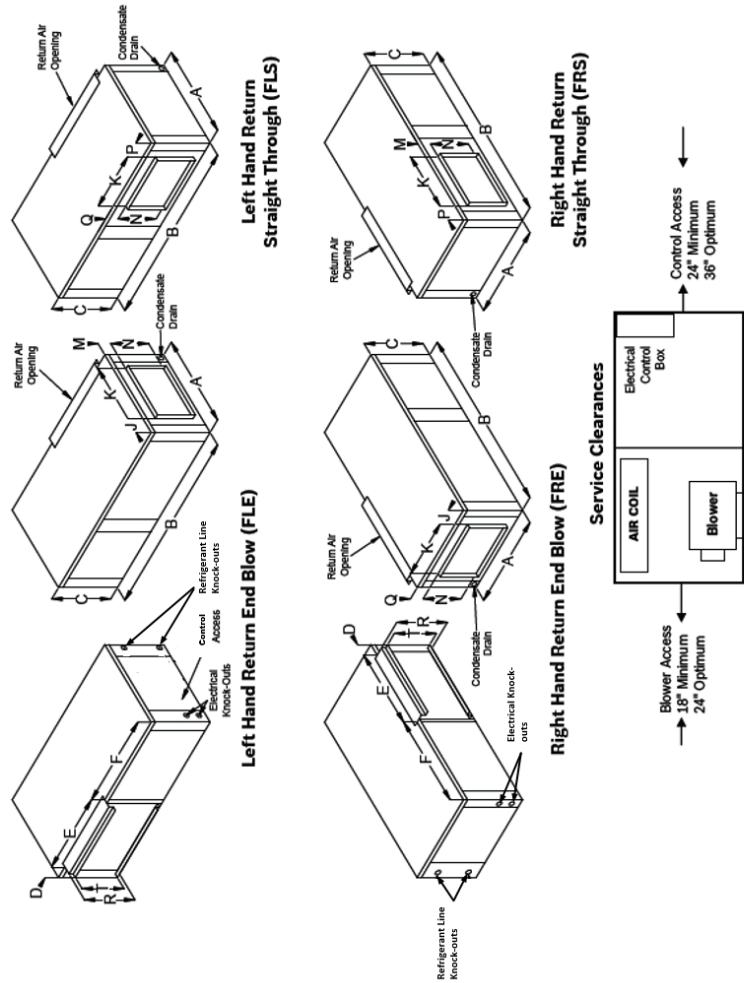

**NOTE:** The local electric codes may require 36" or more clearance at the electrical control box. Subject to change without prior notice.

Model	A	B	C	D	E	F	G	H	J	K	L	M	N	P	Recommended Replacement Nominal Filter Size	
	Width	Depth	Height	Discharge Depth	Discharge Width	Cabinet Front to Discharge	Side to Discharge	Bottom to Condensate Drain	Side to Condensate	Front to R/A	Bottom to Discharge	R/A Duct Width	R/A Duct Flange Height	Filter Rack Height	Condensate Drain Connection	
LV018	21.5	21.5	21.62	14.0	14.0	4.5	5.2	1.0	4.4	1.8	1.6	18.0	18.0	16.0	3/4" F.P.T.	20x20x1
LV024	21.5	21.5	21.62	14.0	14.0	4.5	5.2	1.0	4.4	1.8	1.6	18.0	18.0	20.0	3/4" F.P.T.	20x20x1
LV030	21.5	21.5	21.62	14.0	14.0	4.5	5.2	1.0	4.4	1.8	1.6	18.0	18.0	20.0	3/4" F.P.T.	20x20x1
LV036	21.5	26.0	25.62	16.0	14.0	6.2	5.0	1.0	4.4	2.0	1.6	22.0	22.0	24.0	3/4" F.P.T.	24x24x1
LV042	21.5	26.0	25.62	16.0	14.0	6.2	5.0	1.0	4.4	2.0	1.6	22.0	22.0	24.0	3/4" F.P.T.	24x24x1
LV048	24.0	32.5	25.62	18.0	14.0	7.5	6.2	1.0	4.4	2.3	1.6	28.0	22.0	24.0	3/4" F.P.T.	24x30x1
LV060	24.0	32.5	25.62	18.0	14.0	7.5	6.2	1.0	4.4	2.3	1.6	28.0	22.0	24.0	3/4" F.P.T.	24x30x1
LV070	33.3	26.00	33.62	18.0	16.0	7.5	7.2	1.0	4.4	2.6	1.6	28.0	30.0	32.0	3/4" F.P.T.	16x30x1 (2)

All dimensions within ±0.125.  
 All dimensions in inches.  
 Specifications subject to change without notice

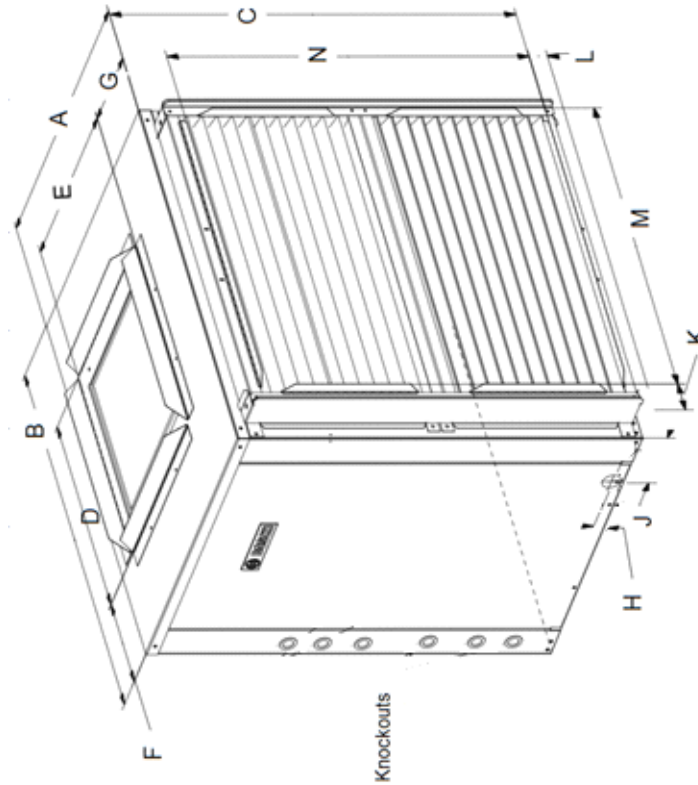

Notes:  
 1" filter rack extends 1.23" beyond the side of the unit  
 2" filter rack extends 2.89" beyond the side of the unit  
 2" filter rack length is .2" longer, lengthening dim M by 2"  
 The 2" filter rack is 4 sided with a filter access door on each end and can accept either a 1" or 2" filter.  
 Refrigerant line connections are located in back corner. Field piping can be brought in through knockouts located in front or back corner.  
 On units 018, 024, 030 the left hand configuration comes with the e-box in the back of the unit but can be accessed through the front



## NOTES



# BOSCH

601 N.W. 65th Court, Ft. Lauderdale, FL 33309  
Phone: 866-642-3198 | Fax: 954-776-5529  
[www.boschtaxcredit.com](http://www.boschtaxcredit.com) | [www.FHP-MFG.com](http://www.FHP-MFG.com)  
Revised 01-15

