

LM Split AH/AV Air Handler



LM024 | LM036 | LM048 | LM060



BOSCH

Installation, Operation, and Maintenance Manual

8733826257 (2020/06)

CONTENTS

Document Conventions	3
Key to Symbols.....	3
Safety Warnings.....	3
Model Nomenclature	4
CS/Air Handler Pairings.....	5
LM Split AH/AV Standard Package.....	6
General Description	6
Moving and Storage	6
Initial Inspection	6
Unit Installation	7
Location Selection.....	7
Air Handler Location.....	7
Condensing Section Location	7
Installation	7
Air Handler Section Installation	8
Hanging Bracket Kit.....	8
Condensate Drain	9
Duct System	10
Electrical	10
Electronic Thermostat Installation	11
Low-Voltage Connection Points	12
ECM Interface Board	13
Thermostat Connections.....	13
Refrigerant Lines	15
Linear vs. Equivalent Line Length	15
Connecting Refrigerant Lines.....	16
Typical System Setup	18
Specific Application Considerations	19
Well Water Systems	19
Cooling Tower/Boiler Systems	19
Geothermal Systems	19
Post-Installation System Checkout.....	20
System Operation	20
Unit Start-up.....	20
Sequence of Operation	20
Troubleshooting.....	22
Unit Lockouts	24
Maintenance.....	25
Decommissioning Information	26
Protecting the Environment.....	26
Check-Out Sheet.....	27
Wiring Diagrams	28

Dimensional Drawings.....	29
Terminology	31
Acronyms	31
Terms.....	31
Notes	32

DOCUMENT CONVENTIONS

Key to Symbols

Warnings



Warnings in this document are identified by a warning triangle printed against a gray background. Keywords at the start of the warning indicate the type and seriousness of the ensuing risk if measures to prevent the risk are not taken.

The following keywords are defined and can be used in this document:

- **DANGER** indicates a situation that, if not avoided, will result in death or serious injury.
- **WARNING** indicates a situation that, if not avoided, could result in death or serious injury.
- **CAUTION** indicates a situation that, if not avoided, could result in minor to moderate injury.
- **NOTICE** is used to address practices not related to personal injury.

Important Information



This symbol indicates important information where there is no risk to property or people.

SAFETY WARNINGS



IMPORTANT: Read the entire instruction manual before starting installation.



WARNING: PERSONAL INJURY HAZARD
Installation and servicing of this equipment can be hazardous due to system pressure and electrical components. Only trained and qualified personnel should install, repair, or service the equipment.



WARNING: ELECTRIC SHOCK
Before performing service or maintenance operations on the system, turn off main power to the unit. Electrical shock could cause personal injury or death.



WARNING: FLAMMABLE REFRIGERANT
R410A is flammable when exposed to open flame. Recover all refrigerant prior to brazing.



WARNING: When working on equipment, always observe precautions described in the literature, tags, and labels attached to the unit. Follow all safety codes. Wear safety glasses and work gloves. Use a quenching cloth for brazing, and place a fire extinguisher close to the work area.

NOTICE: To avoid the release of refrigerant into the atmosphere, the refrigerant circuit of this unit must be serviced only by technicians who meet local, state, and federal proficiency requirements.

NOTICE: All refrigerant discharged from this unit must be recovered WITHOUT EXCEPTION. Technicians must follow industry accepted guidelines and all local, state, and federal statutes for the recovery and disposal of refrigerants. If a compressor is removed from this unit, refrigerant circuit oil will remain in the compressor. To avoid leakage of compressor oil, refrigerant lines of the compressor must be sealed after it is removed.

NOTICE: To avoid equipment damage, DO NOT use these units as a source of heating or cooling during the construction process. Doing so may affect the unit's warranty. The mechanical components and filters will quickly become clogged with construction dirt and debris, which may cause system damage or failure.



WARNING: This product can expose you to chemicals including Lead and Lead components, which are known to the State of California to cause cancer and birth defects or other reproductive harm.

For more information go to www.P65Warnings.ca.gov.

CS/AIR HANDLER PAIRINGS

UNIT MODEL	Paired Air Handler	
	Pairing 1	Pairing 2
LM024-1CS	LM024-1AVX	LM024-1AHX
LM036-1CS	LM036-1AVX	LM036-1AHX
LM048-1CS	LM048-1AVX	LM048-1AHX
LM060-1CS	LM060-1AVX	LM060-1AHX
LEGEND:		
AVX	BOSCH Box Style Vertical Air Handler	
AHX	BOSCH Box Style Horizontal Air Handler	

LM SPLIT AH/AV STANDARD PACKAGE

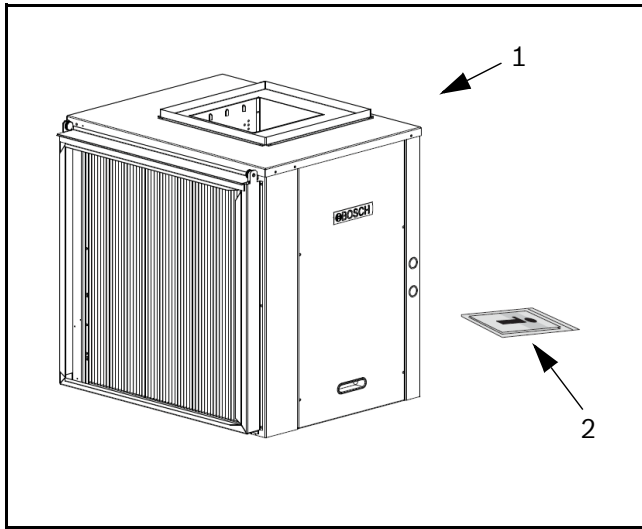

Fig. 2 LM Split Series Water-to-Air Heat Pump Air Handler

- [1] LM Split Series Water-to-Air Heat Pump Air Handler
- [2] Installation and Operation Manual

General Description

LM Split Series Water-to-Air Heat Pumps provide the best combination of performance and efficiency available. All units are performance certified to American Heating and Refrigeration Institute (AHRI) ISO Standard 13256-1. All LM Water-to-Air Heat Pumps conform to UL 1995 standard and are certified to CAN/CSA C22.1 No 236 by Intertek-ETL.

Split system heat pumps consist of two independently installed sections allowing for centralized air distribution while remotely locating the section containing the compressor and water-to-refrigerant heat exchanger (Coax Water Coil).

In the cooling mode, the air coil in the air handler section serves as an evaporator and the water-to-refrigerant heat exchanger serves as a condenser. In the heating mode, their roles are reversed.

In cooling mode, the refrigerant lines connecting the two sections consist of one line carrying liquid refrigerant and another carrying refrigerant vapor. The liquid carrying line will be referred to as the liquid line while the vapor carrying line will be referred to as the suction line.

The Water-to-Air Heat Pumps are designed to operate with entering fluid temperature between 20°F to 80°F in the heating mode and between 50°F to 110°F in the cooling mode.



Antifreeze solution is required for entering fluid temperatures below 50°F. Reference the installation and operational manual for the LM Condensing Section for additional details based on unit application.

NOTICE: This product should not be used for temporarily heating/cooling during construction. Doing so may effect the units warranty.

Moving and Storage

If the equipment is not needed for immediate installation upon its arrival at the job site, it should be left in its shipping carton and stored in a clean and dry area. Units must only be stored or moved in the normal upright position as indicated by the “UP” arrows on each carton at all times.

Initial Inspection

Be certain to inspect all cartons or crates on each unit as received at the job site before signing the freight bill. Verify that all items have been received and that there are no visible damages; note any shortages or damages on all copies of the freight bill. In the event of damage or shortage, remember that the purchaser is responsible for filing the necessary claims with the carrier. Concealed damages not discovered until after removing the units from the packaging must be reported to the carrier within 24 hours of receipt.

UNIT INSTALLATION

This section contains information on the following:

Subject	Page
Location Selection	7
Installation	7
Duct System	10
Electrical	10
Refrigerant Lines	15
Typical System Setup	18
Specific Application Considerations	19
Post-Installation System Checkout	20

NOTICE: To avoid equipment damage, DO NOT use these units as a source of heating or cooling during the construction process. Doing so may affect the unit's warranty. The mechanical components and filters will quickly become clogged with construction dirt and debris, which may cause system damage.

LOCATION SELECTION

To maximize system performance, efficiency and reliability, and to minimize installation costs, it is always best to keep the refrigerant lines as short as possible. Every effort should be made to locate the air handler and the condensing section as close as possible to each other.

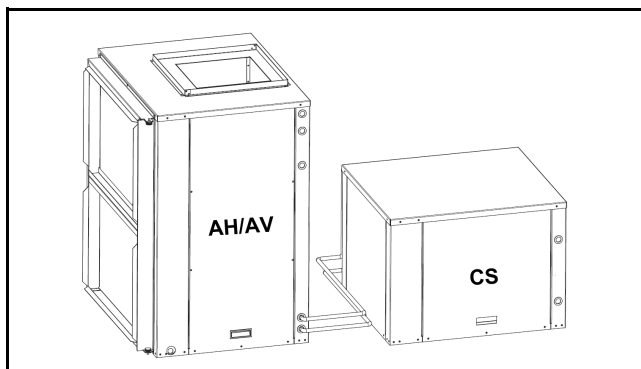

Fig. 3 Air Handler and the Condensing Section

NOTICE: These units are not approved for outdoor installation; therefore, they must be installed inside a structure in a conditioned space. Do not locate in areas that are subject to freezing.

Air Handler Location

Locate the air handler unit in an indoor area that allows easy removal of the filter and access panels, and has enough room for service personnel to perform maintenance or repair. Provide sufficient room to make electrical and duct connections. If the unit is located in a confined space such as a closet, provisions must be made for return air to freely enter that space.

Condensing Section Location

Locate the condensing section in an area that provides sufficient room to make water and electrical connections, and allows easy removal of the access panels, for service personnel to perform maintenance or repair. The condensing section is designed for indoor use only.



Reference the installation and operation manual for your LM Split Condensing Section for detailed installation instructions.

INSTALLATION



Remove all shipping blocks from the inside and/or outside of the air handler section prior to final installation.



WARNING: The installer should comply with all local codes and regulations which govern the installation of this type of equipment. Local codes and regulations take precedent over any recommendations contained in these instructions. In lieu of local codes, the equipment should be installed in accordance with the recommendations made by the National Electric Code, and in accordance with the recommendations made by the National Board of Fire Underwriters.

Air Handler Section Installation

The air handler section may be installed on any level surface strong enough to support its weight. When installed in a closet or on a base stand, it should be mounted on a vibration absorbing pad slightly larger than the base to minimize vibration transmission to the building structure.

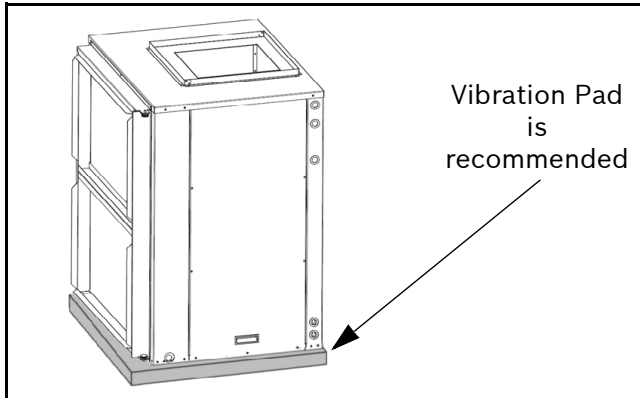

Fig. 4 Vibration Pad

When installed in an attic or above a drop ceiling, the installation must conform to all local codes.

Use the Hanging Bracket Kit to install the unit in a horizontal position (supply air at the end or side of the unit). The unit must be supported on all four corners with threaded rods attached to the building's ceiling rafters.

Some applications require an attic floor installation of the air handling unit. In this case the unit should be set in a full-size secondary drain pan on top of a vibration absorbing mesh. The secondary drain pan prevents possible condensate overflow or water leakage damage to the ceiling. The secondary drain pan is usually placed on a plywood base isolated from the ceiling joists by additional layers of vibration absorbing mesh. In both cases, a 3/4" drain connected to this secondary pan should be run to an eave at a location that will be noticeable. See Fig. 9.

If the air handler is located in a crawl space, the bottom of the unit must be at least 4" above grade to prevent flooding of the electrical parts due to heavy rains.

Hanging Bracket Kit

All horizontal air handler units come with a Hanging Bracket Kit to facilitate suspended unit mounting using threaded rods.



WARNING: Follow all applicable codes and requirements when hanging this unit, selecting threaded rod material, etc.

Included Parts

Quantity	Description
5	Brackets
5	Rubber Vibration Isolators
8	Screws #10 x 1/2"

Table 1 Hanging Bracket Kit Included Parts

Required Parts Not Included

The following are needed and are to be field provided.

Quantity	Description
4	Threaded Rods (3/8" maximum diameter)
4	Hex Nuts
4	Washers (1-3/4" minimum O.D.)

Note: Additional fasteners specific to your installation will be needed to attach the threaded rods to the building's rafters.

Table 2 Hanging Bracket Kit Field-Provided Parts

Installation Instructions

1. Remove and discard factory-provided screws from the locations where hanging brackets will be installed. See Fig. 5.

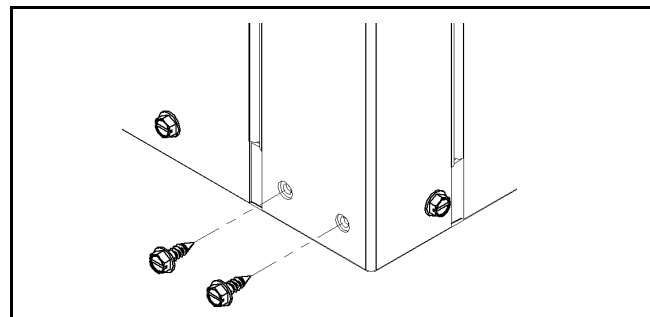

Fig. 5 Screw Locations

- Mount the four Brackets to unit's four corner posts using the screws provided in the kit. Refer to Fig. 6 and Fig. 7.



WARNING: Do not re-use screws removed from the unit on step 1 to mount the Hanging brackets to the unit.

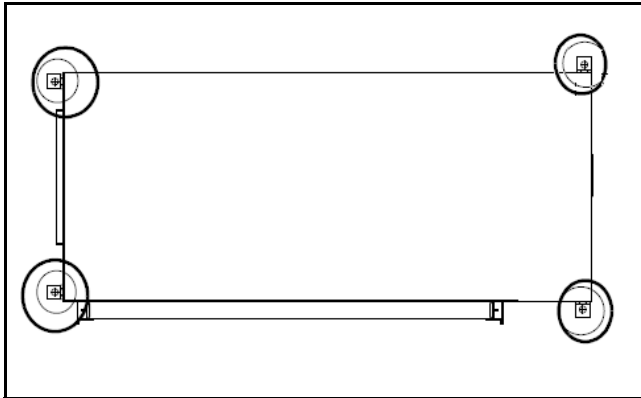

Fig. 6 Four Bracket Mounting Locations

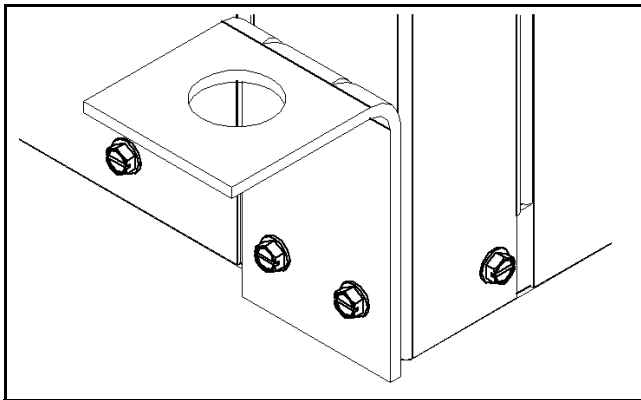

Fig. 7 Mounting Brackets to the Corner Posts

- Install the Rubber Vibration Isolator grommets onto the Brackets as shown in Fig. 8.
- Hang the unit and assemble the field-provided threaded rod, nuts, and washers on to the brackets as shown in Fig. 8.



WARNING: Rods must be securely anchored to the ceiling.

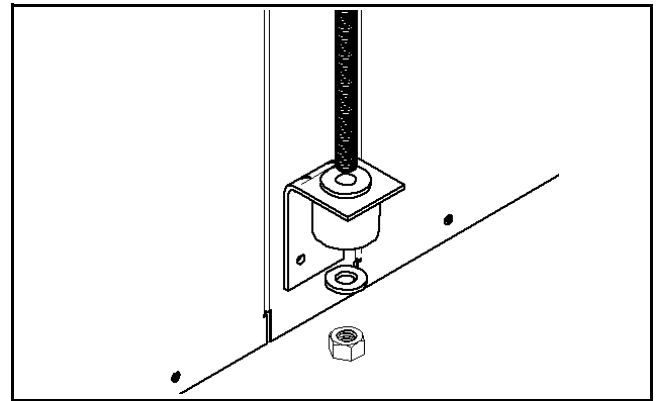

Fig. 8 Connecting the Threaded Rod to the Brackets

Condensate Drain



Plumbing connected to the heat pump must not come in direct contact with joists, trusses, walls, etc.

The air handler should be pitched approximately 1/4" towards the drain in both directions, to facilitate condensate removal. A drain line must be connected to the air handler and pitched away from the unit a minimum of 1/8" per foot to allow the condensate to flow away from the unit. This connection must be in conformance with local plumbing codes.

A trap must be installed in the condensate line to ensure free flow of the condensate. A vertical air vent is sometimes required to avoid air pockets. See Fig. 9. The length of the trap depends on the amount of positive or negative pressure on the drain pan.



Never use a second trap.
Units are not internally trapped.

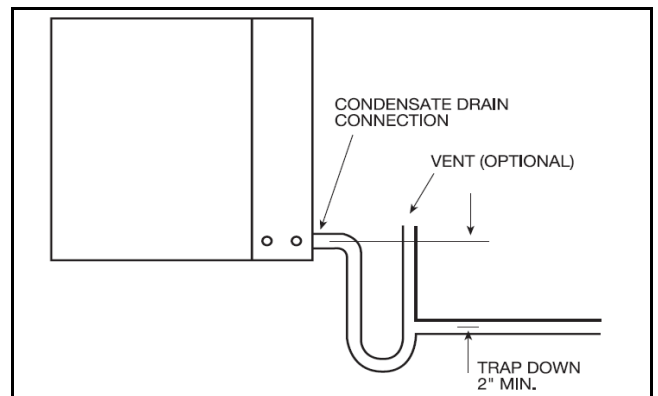

Fig. 9 Condensate Drain

The air handler should be pitched approximately 1/4" towards the drain in both directions, to facilitate condensate removal. See Fig. 10.



Drain Pan is not internally sloped.

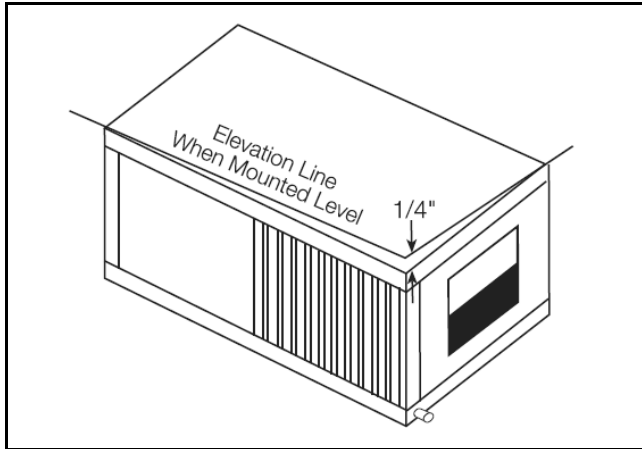

Fig. 10 Air Handler Pitch

DUCT SYSTEM

A supply air outlet collar and return air duct flange are provided on all units to facilitate duct connections.

A flexible connector is recommended for supply and return air duct connections on metal duct systems. All metal ducting should be insulated with a minimum of one inch duct insulation to avoid heat loss or gain and prevent condensate forming during the cooling operation. Application of the unit to uninsulated duct work is not recommended as the unit's performance will be adversely affected.

The factory provided air filter must be removed when using a filter back return air grill. The factory filter should be left in place on a free return system.

If the unit will be installed in a new installation which includes new duct work, the installation should be designed using current ASHRAE procedures for duct sizing. If the unit is to be connected to existing duct work, a check should be made to ensure that the duct system has the capacity to handle the air required for the unit application. If the duct system is too small, larger

duct work should be installed. Also, check for existing leaks and repair.

NOTICE: Do not connect discharge ducts directly to the blower outlet.

The duct system and all diffusers should be sized to handle the designed air flow quietly. To maximize sound attenuation of the unit blower, the supply and return air plenums should be insulated. There should be no direct straight air path through the return air grill into the heat pump.

The return air inlet to the heat pump must have at least one 90 degree turn away from the space return air grille. If air noise or excessive air flow are a problem, the blower speed can be changed to a lower speed to reduce air flow. (Refer to ECM motor interface board section in this manual and Fig. 13.)

ELECTRICAL



WARNING: UNIT OPERATION AND SAFETY HAZARD

Field wiring must comply with local and National Electric Code (NEC).



WARNING: UNIT OPERATION AND SAFETY HAZARD

Power to the unit must be within the operating voltage range indicated on the unit's nameplate or on the performance data sheet.



WARNING: UNIT OPERATION AND SAFETY HAZARD

Properly-sized fuses or HACR circuit breakers must be installed for branch circuit protection. See the unit nameplate for maximum fuse or breaker size.

NOTICE: Operation of unit on improper line voltage or with excessive phase imbalance will be hazardous to the unit, constitutes abuse and may void the warranty.

The unit is provided with a concentric knock-out in the front-left corner post for attaching common trade sizes of conduit, route power supply wiring through this opening. Always connect the ground lead to the grounding lug provided in the control box and power leads to the power supply terminal block as indicated on the wiring diagram.

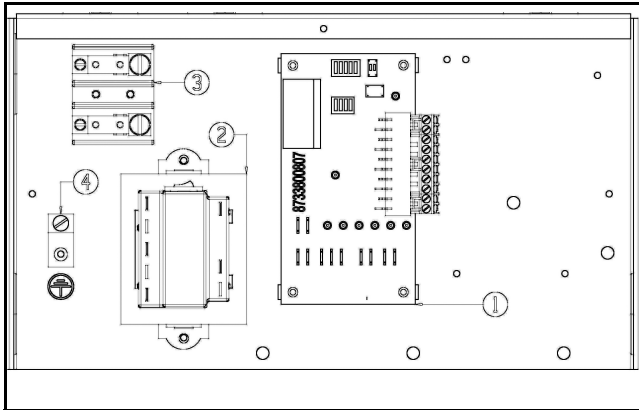

Fig. 11 Electrical Component Box Layout

- [1] ECM Board
- [2] Transformer
- [3] Unit Terminal Block
- [4] Unit Ground Lug

Electronic Thermostat Installation

The unit heat pump can be controlled by most commonly available single-stage heat pump thermostats. Note that the reversing valve (located in the LM Split Condensing Section) is energized when the unit is in the cooling mode. Thermostats should be located on an interior wall away from supply ducts. Avoid locations subject to direct sunlight, drafts, external walls. Thermostat wiring should be 18 AWG (American Wire Gauge) for up to 60 foot, 16 AWG up to 100 ft, and 14 AWG up to 140 ft. Refer to the installation instructions of the thermostats for further details.



When using a 2-cool, 3-heat thermostat both the W1 & W2 on the Heat Pump and W2 & EM on the thermostat must be connected together via a jumper. See Fig. 12.

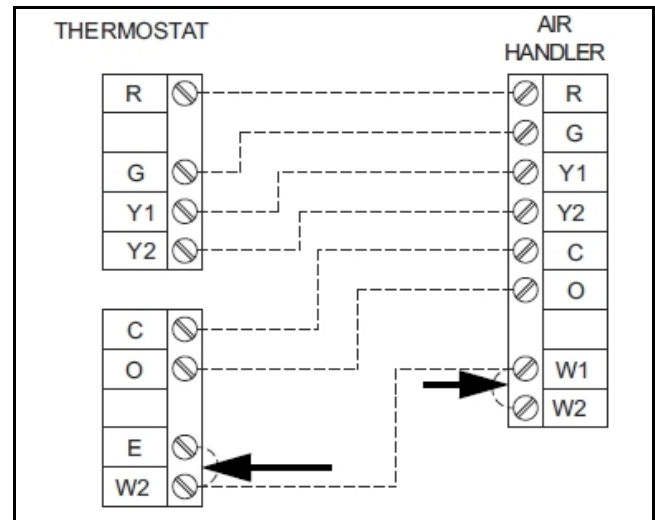

Fig. 12 Thermostat Jumpers



The LM Air Handlers are equipped with detachable Thermostat connectors located on the ECM Interface board. Refer to unit wiring diagram for connection details.



Depending on the options installed, some wires in the Wiring Harness may not be utilized. See Wiring Harness Drawing notes for further details.

Low-Voltage Connection Points

Function	From Thermostat	To Air Handler	From Air Handler	To Condensing Section
24 VAC Common	C	C	C	C
24 VAC Power	R	R	R	R
Fan Operation	G	G	–	–
Reversing Valve ³	O	O	O	O
Compressor 1 st Stage	Y1	Y1	Y1	Y1
Compressor 2 nd Stage	Y2	Y2	Y2	Y2
Condensate Sensor ¹	–	–	CS	CS
Alarm Output (from UPM) ²	L/ALR	Splice		ALR (UPM)
Auxiliary Electric Heat ⁴	W/W1/W2	W1	–	–
Second-Stage Auxiliary Heat/Emergency Heat ⁴	W/E, W1/E, W2/E ⁵	W2	–	–

Table 3 Low-Voltage Connection Points

Tables Notes:

- 1) If the condensate overflow sensor option is utilized connect “CS” at the condensing section to “CS” at the air handler. Be sure to ground power supply.
- 2) If service LED is utilized connect “ALR” terminal on the UPM board to “L” on the thermostat sub base. The wiring may be spliced in the air handling unit. The “ALR” output is hot (R) so check thermostat instruction manual to ensure compatibility.
- 3) “O” – reversing valve is energized in the cooling mode. Fail safe is to heating.
- 4) Utilized when electric strip heater package present.
- 5) Will vary depending on the thermostat.

ECM Interface Board

In addition to providing a connection point for thermostat wiring, the interface board also translates thermostat inputs into control commands for the Electronic Commutated Motor (ECM) fan motor and provides thermostat signals to the unit's UPM board (located in the LM condensing section).

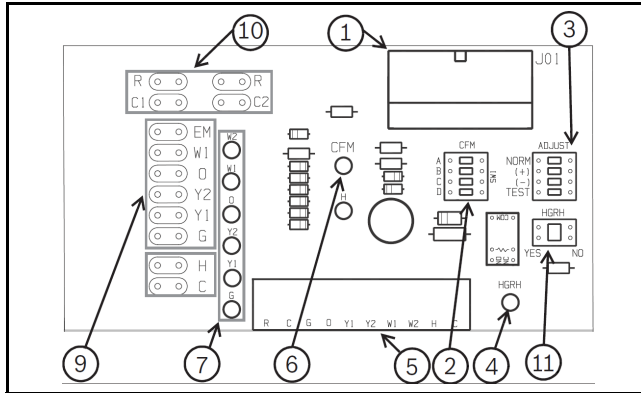

Fig. 13 ECM Interface Board

- [1] Motor Harness Plug
- [2] Blower CFM Adjustment
- [3] Motor Settings
- [4] Dehumidification Indication
- [5] Thermostat Contact Inputs
- [6] CFM Count Indicator
- [7] Thermostat Input Status Indication
- [8] Reheat Digital Outputs
- [9] Thermostat Outputs
- [10] 24 VAC
- [11] Dehumidification Method Selector

Thermostat Connections

Thermostat wiring is connected to the 10-pin screw type terminal block on the lower-center portion of the ECM Interface Board. (See Fig. 13) In addition to providing a connecting point for thermostat wiring, the interface board also translates thermostat inputs into control commands for the variable speed programmable ECM DC fan motor and displays an LED indication of operating status.

The thermostat connections and their functions are as follows:

Connection	Function
Y2	Second-Stage Compressor Operation
Y1	First-Stage Compressor Operation
G	Fan
O	Reversing Valve (energized in cooling)
W1	Auxiliary Electric Heat (runs as supplemental heat when needed along with compressor)
W2	Second-Stage Auxiliary Heat/Emergency Heat
C	Transformer 24 VAC Common (extra connection)
C1	Transformer 24 VAC Common (primary connection)
R	Transformer 24 VAC Hot
HUM	Passive Dehumidification Mode

Table 4 Thermostat Connections

If the unit is being connected to a thermostat with a malfunction light, this connection is made at the unit alarm output.



If the thermostat is provided with a malfunction light powered off of the common (C) side of the transformer, a jumper between "R" and "COM" terminal of "ALR" contacts must be made.



If the thermostat is provided with a malfunction light powered off of the hot (R) side of the transformer, then the thermostat malfunction light connection should be connected directly to the (ALR) contact on the unit's UPM board.

On the above series units the thermostat wiring connections are made at the air handling section. This will allow the capability to utilize both the condensate overflow switch and the alarm output.

Bosch recommends the use of 18 AWG thermostat conductive cable for up to 60 foot, 16 AWG up to 100 ft, and 14 AWG up to 140 ft. to wire from the condensing section terminal strip to the air handler terminal strip.

Connection point logic is as follows:

To the left of the thermostat connection block are a row of 2 red and 4 green LEDs. These LEDs indicate the operating status of the unit. (See Fig. 13.) They are labeled as follows:

Connection	Color	Operating Status
EM	RED	Emergency Heat ON
W1	RED	Auxiliary Heat ON
O	GREEN	Reversing Valve Energized, unit is in cooling mode
Y2	GREEN	Second-Stage Compressor ON
Y1	GREEN	First-Stage Compressor ON
G	GREEN	Fan ON

Table 5 Connection Point Logic

Motor Profile Air-Flow Table CFM

Motor	Fan Only	Y1 Cool/Heat	Y2 Cool/Heat	AUX Heat	Emerg. Heat	Plus ADJ	Minus ADJ	Tap Cool/Heat/Delay
LM024	450	500	800	800	800	900	700	A
LM036	700	1050	1225	1225	1225	1400	1050	A
LM048	900	925	1500	1500	1500	1700	1275	B
LM060	1200	1500	2000	2000	2000	2300	1700	A

Table 6 Motor Profile Air-Flow Table CFM

Just above and to the right of the thermostat connection block are DIP Switches labeled ADJ, DELAY, HEAT and COOL. The ADJ set of pins are labeled NORM, (+), (-) and TEST. LM units will all be set on the NORM position from the factory, however, airflow can be increased (+) or decreased (-) by 15% from the pre-programmed setting by relocating the jumper in this section. The TEST position is used to verify proper motor operation. If a motor problem is suspected, move the ADJ jumper to the TEST position and energize G on the thermostat connection block. If the motor ramps up to 100% power, then the motor itself is

Just above the connector block is a single-red LED labeled CFM that will blink intermittently when the unit is running and may flicker when the unit is off. This LED indicates the air delivery of the blower at any given time. Each blink of the LED represent 100 CFM of air delivery so if the LED blinks 12 times, pauses, blinks 12 times, etc. the blower is delivering 1200 CFM. Refer to Table 6 for factory-programmed air delivery settings for the LM Series.



To the right of the thermostat connection block is a green LED labeled dehumidify. On dehumidification call the fan will operate at a lower speed to increase dehumidification while cooling.

functioning normally. Always remember to replace the jumper to NORM, (+) or (-) after testing and reset the unit thermostat to restore normal operation. (See Fig. 13.)

NOTICE: Do not set the ADJ jumper to the (-) setting when electric heaters are installed. Doing so may cause the heaters to cycle on their thermal overload switches, potentially shortening the life of the switches.

The other three sets of jumper pins are used to

select the proper program in the ECM motor for the unit. Refer to Fig. 13 for the proper jumper placement.

NOTICE: Always disconnect power before changing jumper positions on the interface board and reset the unit afterward.

To the left of the red and green status LEDs is a row of 1/4" male quick connects. (See Fig. 13.) These are used to pass thermostat inputs on to the rest of the control circuit. Remember to always turn off unit power at the circuit breaker before attaching or disconnecting any wiring from these connections to avoid accidental short circuits that can damage unit control components.

REFRIGERANT LINES

The installation of the copper refrigerant tubing must be done with care to obtain reliable, trouble-free operation. This installation should only be performed by qualified refrigeration service and installation personnel.

Refrigerant lines generally can and should be routed and supported so as to prevent the transmission of vibrations into the building structure. Experience and good design practice dictate 75 feet as the maximum practical length for interconnecting refrigerant lines in split system heat pumps without special considerations.

Beyond 75 feet, system losses become substantial and the total refrigerant charge required can compromise the reliability and design life of the equipment.

Copper tubing should be clean and free of moisture and dirt or debris. The suction and liquid lines **MUST** be insulated with at least 3/8" wall, closed-cell foam rubber insulation or the equivalent.

Some points to consider are:

- Pressure drop (friction losses) in refrigerant suction lines reduces system capacity and increases power consumption by as much as 2% or more, depending on the line length, number of bends, etc. Pressure drop in liquid lines affects system performance to a lesser degree, provided that a solid column of liquid (no flash gas) is being delivered to the refrigerant metering device, and that the liquid pressure at the refrigerant metering device is sufficient to produce the required refrigerant flow.
- Oil is continually being circulated with the refrigerant so, oil return to the compressor is always a consideration in line sizing. Suction lines on split system heat pumps are also hot gas lines in the heating mode, but are treated as suction lines for sizing purposes. If the recommended suction lines sizes are used, there should be no problem with oil return.
- Vertical lines should be kept to a minimum. Vertical liquid lines will have a vertical liquid lift in either heating or cooling, and the weight of the liquid head is added to the friction loss to arrive at the total line pressure drop.
- Wherever possible, the air handler should be installed at a higher elevation than the condensing section to aid with oil return to the compressor.

Linear vs. Equivalent Line Length

Linear Line Length – is the actual measured length of the line including bends. This is used to calculate the additional refrigerant charge that must be added to the system (See Table 8 and Table 9 for charge information).

Equivalent Line Length – is the combination of the actual length of all the straight runs and the equivalent length of all bends valves and fittings in a particular line. The equivalent length of a bend, valve or fitting is equal to the length of a straight tube of the same diameter having the same pressure drop as the particular valve or fitting. The ASHRAE Fundamentals Handbook provides tables for determining the equivalent length of various bends, valves and fittings.

Connecting Refrigerant Lines

- Use only ACR grade copper tubing and keep ends sealed until joints are made.
- For best performance, select routing of refrigerant lines for minimum distance and fewest number of bends.
- Size lines in accordance with Table 8.
- Cut crimped ends off the air handler suction and liquid lines. Connect and braze lines to the air handler.



The air handler is factory supplied with a holding charge of dry nitrogen.

- Connect and braze lines to service valves on the condensing section.

NOTICE: Always wrap the body of the service valve with a wet towel or apply some other form of heat sink prior to brazing and direct flame away from the valve body. Failure to do so will result in damage to the valve. Valve body temperature must remain below 250°F to protect the internal rubber “O” rings and seals.

Valve Sizing Chart

Unit Size	Line Type	Valve Conn. Size	Hex (Allen) Wrench Size
LM024/036	Suction	3/4	5/16
LM048/060	Suction	7/8	5/16
ALL	Liquid	3/8	3/16

Table 7 Valve Sizing Chart

Pressurize the refrigerant line set and air handler to 150lbs with dry nitrogen through the ports provided on the self service valves. Check line set and unit connections for leaks.

Once system integrity is verified, evacuate line set and air handler with a good vacuum pump to 500 microns and hold for half hour.



Pump down must never be used with heat pumps.

Refrigerant Charge, Line Sizing, and Capacity Multiplier Chart

System Models	Factory R410A Charge (Oz)*	Refrigerant Line O.D. Size (Based on Equivalent Line Length)										Suction Line Riser Max.
		25 FT.		36 FT.		45 FT.		50 FT.		75 FT.		
		LIQ.	SUC.	LIQ.	SUC.	LIQ.	SUC.	LIQ.	SUC.	LIQ.	SUC.	
LM024	80	3/8	3/4	3/8	3/4	3/8	3/4	3/8	3/4	3/8	7/8	3/4
LM036	86	3/8	3/4	3/8	3/4	3/8	3/4	3/8	7/8	3/8	7/8	3/4
LM048	88	3/8	7/8	3/8	7/8	3/8	7/8	3/8	7/8	3/8	7/8	7/8
LM060	115	3/8	1-1/8	3/8	1-1/8	3/8	1-1/8	3/8	1-1/8	3/8	1-1/8	7/8
CAPACITY MULTIPLIER		1.00		0.995		0.990		0.990		0.980		
EXAMPLE 1: Model LM036 with 45 ft. of equivalent length of 3/8" O.D. Liquid Line. Total System Charge= Factory Charge + (45 ft. - 25 ft.) x .60 oz./ft. Total System Charge = 93 oz. + (20 ft. x .60 oz./ft.) = 105 oz. Additional 12 oz. of R410A refrigerant required.						EXAMPLE 2: Model LM060 with 10 ft. of equivalent length of 3/8" O.D. Liquid Line. Total system charge= Factory charge + (25 ft. -10 ft.) x .60 oz./ft. Total System Charge = 150 oz. + (15 ft. x .60 oz./ft.) = 141 oz. Additional 12 oz. of R410A refrigerant required.						

Table 8 Refrigerant Charge, Line Sizing, and Capacity Multiplier Chart

Liquid Line Charge per Linear Foot

LIQUID LINE SIZE, O.D.	1/4	5/16	3/8	1/2	5/8
R410A OZ PER FOOT	.25	.44	.60	1.15	1.95

Table 9 Liquid Line Charge per Linear Foot

TYPICAL SYSTEM SETUP

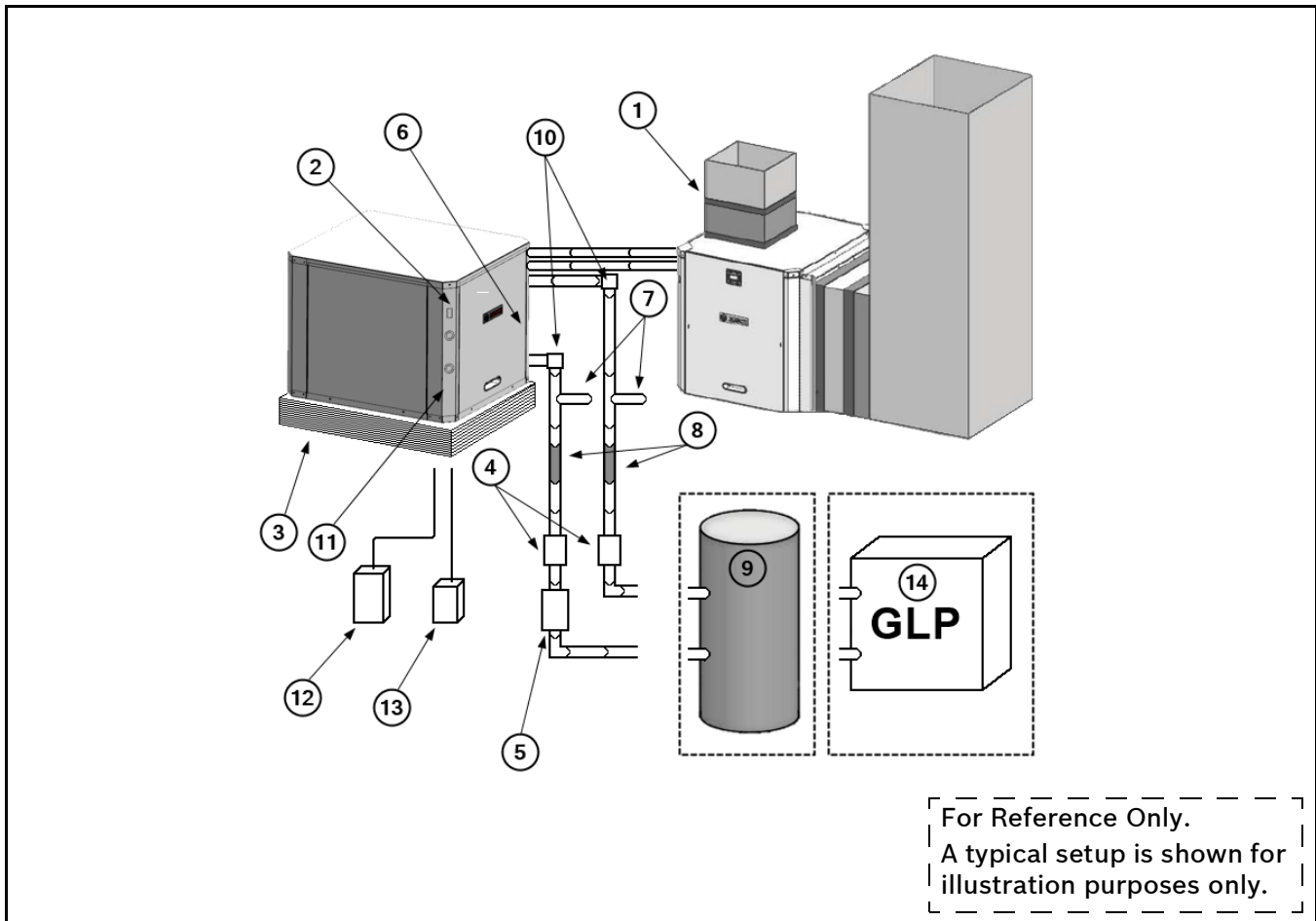

Fig. 14 Typical Setup

- [1] Flex Duct Connection
- [2] Low Voltage Control Connection
- [3] Vibration Pad
- [4] Ball Valves
- [5] Solenoid Valve Slow Closing
- [6] Condensate Drain Connection
- [7] Drain Valves
- [8] Hose Kits (optional)
- [9] Pressure Tank (optional)
- [10] P/T Ports (optional)
- [11] Line Voltage Connection
- [12] Electric Heater Line Voltage Disconnect
- [13] Unit Line Voltage Disconnect
- [14] Ground Loop Pumping Package



Typical Layout Illustration. See Fig. 9 for
Condensate Drain Connection.

SPECIFIC APPLICATION CONSIDERATIONS

Well Water Systems

(Refer to Fig. 14)

In well water applications water pressure must always be maintained in the heat exchanger. This can be accomplished with either control valve or a bladder type expansion tank. When using a single water well to supply both domestic water and the heat pump care must be taken to ensure that the well can provide sufficient flow for both. In well water applications a slow-closing solenoid valve must be used to prevent water hammering.

Solenoid valves should be connected across Y1 and C1 on the interface board for all. Make sure that the VA draw of the valve does not exceed the contact rating of the thermostat.

Cooling Tower/Boiler Systems

(Refer to Fig. 14)

The cooling tower and boiler water loop temperature is usually maintained between 50°F to 100°F to ensure adequate cooling and heating performance. In the cooling mode, heat is ejected from the unit into the water loop. A cooling tower provides evaporative cooling to the loop water thus maintaining a constant supply temperature to the unit. When utilizing open cooling towers, chemical water treatment is mandatory to ensure the water is free from corrosive elements. A secondary heat exchanger (plate frame) between the unit and the open cooling tower may also be used.

It is imperative that all air be eliminated from the closed-loop side of the heat exchanger to ensure against fouling. In the heating mode, heat is absorbed from the water loop. A boiler can be utilized to maintain the loop at the desired temperature.

Cooling Tower/Boiler Systems Piping

NOTICE: Water piping exposed to extreme low ambient temperatures is subject to freezing.



Thread sealant tape should be used when connecting to the unit to insure against leaks and possible heat exchanger fouling.



Do not overtighten the connections.

Flexible hoses should be used between the unit and the rigid system to avoid possible vibration.

Ball valves should be installed in the supply and return lines for unit isolation and unit water flow balancing.

Pressure/temperature ports are recommended in both supply and return lines for system flow balancing. Water flow can be accurately set by measuring the water-to-refrigerant heat exchangers' water-side pressure drop. (See specification sheets for water flow vs. pressure drop information.)

No unit should be connected to the supply or return piping until the water system has been completely cleaned and flushed to remove any dirt, piping chips, or other foreign material. Supply and return hoses should be connected together during this process to ensure the entire system is properly flushed. After the cleaning and flushing has taken place, the unit may be connected to the water loop and should have all valves wide open.

Geothermal Systems

(Refer to Fig. 14)

Closed-loop and pond applications require specialized design knowledge. No attempt at these installations should be made unless the dealer has received specialized training. Using the Ground Loop Pumping Package (GLP), makes the installation easy. Anti-freeze solutions are utilized when low-evaporating conditions are expected to occur. Refer to the GLP installation manuals for specific instructions.

POST-INSTALLATION SYSTEM CHECKOUT

After completing the installation and before energizing the unit, the following system checks MUST be made:

1. Verify that the supply voltage to the heat pump is in accordance with the nameplate ratings.
2. Make sure that all electrical connections are tight and secure.
3. Check the electrical fusing and wiring for the correct size.



DANGER: Ensure the cabinet and electrical box are properly grounded.

4. Verify that the low-voltage wiring between the thermostat and the unit is correct.
5. Verify that the water piping is complete and correct.
6. Check that the water flow is correct and adjust if necessary.
7. Check the blower for free rotation, and that it is secured to the shaft.
8. Verify that vibration isolation has been provided.
9. Ensure the unit is serviceable.
10. Confirm that all access panels are secured in place.



IMPORTANT:

- Always check incoming line-voltage power supply and secondary control voltage for adequacy. Transformer primaries are dual tapped for 208 and 230 volts. Connect the appropriate tap to ensure a minimum secondary control voltage of 18 volts. 24 volts is ideal for best operation.
- Long-length thermostat and control wiring leads may create voltage drop. Increase wire gauge or up-size transformers may be required to ensure minimum secondary voltage supply.
- Bosch recommends the following guidelines for wiring between a thermostat and the unit: 18 AWG up to 60 foot, 16 AWG up to 100 ft and 14 AWG up to 140 ft.
- Do not apply additional controlled devices to the control circuit power supply without consulting the factory. Doing so may void equipment warranties.
- Check with all code authorities on installation criteria including condensate disposal/overflow protection criteria.

SYSTEM OPERATION

UNIT START-UP

1. Place the UPM board in “Test” mode.
2. Set the thermostat to the highest setting.
3. Set the thermostat system switch to “COOL” and the fan switch to the “AUTO” position. The reversing valve solenoid should energize. The compressor should not run.
4. Reduce the thermostat setting approximately five degrees below the room temperature.
5. Verify the heat pump is operating in the cooling mode.
6. Turn the thermostat system switch to the “OFF” position. The unit should stop running and the reversing valve should de-energize.
7. Leave the unit off for approximately five minutes to allow for system equalization.
8. Turn the thermostat to the lowest setting.
9. Set the thermostat switch to “HEAT.”
10. Increase the thermostat setting approximately five degrees above the room temperature.
11. Verify the heat pump is operating in the heating mode.
12. Set the thermostat to maintain the desired space temperature.
13. Check for vibrations, leaks, etc.

SEQUENCE OF OPERATION

(See Fig. 12 Wire Schematic)

Cooling Mode

Energizing the “O” terminal energizes the unit reversing valve thus placing the unit into cooling mode. The fan motor starts when the “G” terminal is energized.



The fan motor takes 30 seconds to ramp up to operating speed and will run at the fan-only rated airflow, as long as there is no call for compressor or heater operation.

When the thermostat calls for first-stage cooling (Y1) the loop pump or solenoid valve, if present, is energized and the first stage of the compressor capacity starts.



Some options will have a built-in delay, and hence, compressor operation is not immediate.

When the thermostat calls for second-stage cooling (Y2) the second stage (or full-compressor capacity) is initiated. The fan ramps up to full cooling airflow.

Once the thermostat is satisfied, the compressor shuts down and the fan ramps down. If the “G” terminal is still energized (fan operation is on “continuous” at the thermostat) the fan will ramp down to fan only air flow in 30 seconds. If the “G” terminal is de-energized with “Y1” then the fan ramps down to off in 30 seconds.



A fault condition initiating a lockout will de-energize the compressor irrespective of which stage is engaged.

Heating Mode

The first two stages of heating (Y1 & Y2) operate in the same manner as cooling, but with the reversing valve de-energized. On a call for auxiliary heat (W1), the fan ramps up to auxiliary heat airflow immediately and the electric heater package is energized along with the compressor. As the thermostat is satisfied, the heaters will shut off as soon as W1 is de-energized, and the compressors will remain on until the thermostat stages are satisfied.



If the unit compressor lock out for any reason at this time, the electric heaters will continue to function normally.

Once the thermostat is satisfied, the compressor shuts down and the fan ramps down to either fan-only mode or off over a span of 30 seconds. If thermostat has two different output points, one for Auxiliary heat and a different one for Emergency heat, the two outputs must be terminated on W1 units equipped with one stage of Electric heat.

Emergency heat (W2/EM) energizes the emergency heat relay in the heater control box, bringing on all of the heating elements at once. The fan immediately ramps up to full electric heat airflow.



When using a 2-cool, 3-heat thermostat both the W1 & W2 on the Heat Pump and W2 & EM on the thermostat must be connected together via a jumper.

TROUBLESHOOTING



A possible fault may be one or a combination of causes and solutions. Check each cause and adopt “process of elimination” and or verification of each before making any conclusion.

Unit Troubleshooting		
Problem	Possible Cause	Checks and Corrections
ENTIRE UNIT DOES NOT RUN	Power Supply Off	Close disconnect, apply power
	Blown Fuse/Tripped Breaker	Replace fuse or reset circuit breaker. If using fuses, ensure they are the correct size.
	Voltage Supply Low	If voltage is below minimum voltage specified on unit data plate, contact local power company.
	Thermostat	Set the fan to “ON,” the fan should run. Set thermostat to “COOL” with the lowest temperature setting, the unit should run in the cooling mode (reversing valve energized). Set unit to “HEAT” with the highest temperature setting, the unit should run in the heating mode. If neither the blower or compressor run in all three cases, the thermostat could be miswired or faulty. To ensure miswired or faulty thermostat verify that 24 volts is available on the condensing section low-voltage terminal strip between “R” and “C,” “Y” and “C,” and “O” and “C.” If the blower does not operate, verify that there is 24 volts between terminals “G” and “C” in the air handler. Replace the thermostat if defective.
UNIT OFF DUE TO HIGH-PRESSURE CONTROL	Discharge Pressure is Too High	If in “COOLING” mode: Lack of or inadequate water flow. Entering water temperature is too warm. Scaled or plugged condenser. If in “HEATING” mode: Lack of or inadequate load side fluid flow. Blower inoperative, clogged filter or restrictions in duct work.
	Refrigerant Charge	The unit is overcharged with refrigerant. Reclaim refrigerant, evacuate and recharge with the factory recommended charge.
	High-Pressure Switch	Check for a defective or improperly calibrated high-pressure switch.
UNIT OFF TO LOW-PRESSURE CONTROL	Suction Pressure Too Low	If in “COOLING” mode: Lack of or inadequate airflow. Entering air temperature is too cold. Blower inoperative, clogged filter or restrictions in duct work. If in “HEATING” mode: Lack of or inadequate water flow. Entering water temperature is too cold. Scaled or plugged condenser.
	Refrigerant Charge	The unit is low on refrigerant. Check for refrigerant leak, repair, evacuate and recharge with factory recommended charge.
	Low-Pressure Switch	Check for defective or improperly calibrated low-pressure switch.

Unit Troubleshooting		
Problem	Possible Cause	Checks and Corrections
UNIT SHORT CYCLES	Unit Oversized	Recalculate heating and or cooling loads.
	Thermostat	If the thermostat is installed near a supply air grill, relocate thermostat. Adjust the heat anticipator.
	Wiring and Controls	Check for defective or improperly calibrated low-pressure switch.
INSUFFICIENT COOLING OR HEATING	Unit Undersized	Recalculate heating and or cooling loads. If excessive, possibly adding insulation and shading will rectify the problem.
	Loss of Conditioned Air by Leakage	Check for leaks in duct work or introduction of ambient air through doors or windows.
	Airflow	Lack of adequate airflow or improper distribution of air. Replace dirty filter.
	Refrigerant Charge	Refrigerant charge low causing inefficient operation.
	Compressor	Check for defective compressor. If discharge is too low and suction pressure is too high, compressor is not pumping properly. Replace compressor.
	Reversing Valve	Defective reversing valve creating bypass of refrigerant from discharge of suction side of compressor. Replace reversing valve.
	Operating Pressures	Compare unit operation pressures to the pressure/temperature chart for the unit.
	TXV	Check TXV for possible restriction or defect. Replace if necessary.
	Moisture, Non-condensables	The refrigerant system may be contaminated with moisture or non-condensables. Reclaim refrigerant, replace filter dryer, evacuate the refrigerant system, and recharge with factory recommended charge.
BLOWER OPERATES BUT COMPRESSOR DOES NOT	Thermostat	Check setting, calibration, and wiring.
	Wiring	Check for loose or broken wires at compressor, capacitor, or contactor.
	Safety Controls	Check UPM board red default L.E.D. for Blink Code
	Compressor Overload Open	If the compressor is cool and the overload will not reset, replace compressor.
	Compressor Motor Grounded	Internal winding grounded to the compressor shell. Replace the compressor. If the compressor is burnt out, install a suction filter dryer.
	Compressor Windings Open	After compressor has cooled, check continuity of the compressor windings. If the windings are open, replace the compressor.

Table 10 Unit Troubleshooting

Unit Lockouts

Periodic lockouts almost always are caused by air or water flow problems. The lockout (shutdown) of the unit is a normal protective measure in the design of the equipment. If continual lockouts occur call a mechanic immediately and have them check for: water flow problems, water temperature problems, airflow problems or air temperature problems. Use of the pressure and temperature charts for the unit may be required to properly determine the cause.

MAINTENANCE



WARNING: Installation and servicing of this equipment can be hazardous due to system pressure and electrical components. Only trained and qualified personnel should install, repair, or service the equipment.



WARNING: Before performing service or maintenance operations on the system, turn off the main power to the unit. Electrical shock could cause personal injury or death.



Untrained personnel can only perform basic functions of maintenance such as cleaning coils and replacing filters.

Filter changes or cleanings are required at regular intervals. The time period between filter changes will depend upon type of environment in which the equipment is used. In a single-family home, that is not under construction, changing or cleaning the filter every 60 days is sufficient. In other applications such as motels, where daily vacuuming produces a large amount of lint, filter changes may need to be as frequent as biweekly.

NOTICE: Equipment should never be used during construction due to likelihood of wall board dust accumulation in the air coil of the equipment which permanently affects the performance and may shorten the life of the equipment.

An annual “checkup” by a trained and qualified HVAC mechanic is required. Recording the performance measurements of volts, amps, and water temperature differences for both heating and cooling is recommended. This data should be compared to the information on the unit’s data plate and the data taken at the original startup of the equipment.

Lubrication of the blower motor is not required; however, it may be performed on some motors to extend motor life. Use a **SAE-20** non-detergent electric motor oil.

The condensate drain should be checked annually by cleaning and flushing to insure proper drainage.

DECOMMISSIONING INFORMATION

Only trained and qualified technicians are allowed to decommission and dispose of equipment following the requirements of the Local Authority Having Jurisdiction (AHJ).



WARNING: Decommissioning of this equipment can be hazardous due to system pressure and electrical components. Only trained and qualified personnel should install, repair, service, or disconnect the equipment.

Protecting the Environment



By disposing of this product correctly you will help ensure that the waste undergoes the necessary treatment, recovery, and recycling, thus preventing potentially negative effects on the environment and human health, which could otherwise arise due to inappropriate waste handling.

Components



Many parts in the Heat Pump can be fully recycled at the end of the product life. Contact your city authorities for information about the disposal of recyclable products.

Refrigerant



At the end of the service life of this appliance, and prior to its environmental disposal, a person qualified to work with refrigerant circuits and [AHRI Certified](#)[®] Refrigerant Recovery/Recycling Equipment must recover the refrigerant from within the sealed system.

Hazardous Waste



Some components in the Heat Pump may be considered as hazardous waste, such as batteries. For their disposal contact your local household hazardous waste collection site.

CHECK-OUT SHEET

Customer Data

Customer Name _____ Date _____
 Address _____
 Phone _____ Unit Number _____

Unit Nameplate Data

Unit Make _____
 Model Number _____ Serial Number _____
 Refrigerant Charge (oz) _____
 Compressor: RLA _____ LRA _____
 Blower Motor: FLA (or NPA) _____ HP _____
 Maximum Fuse Size (Amps) _____
 Maximum Circuit Ampacity _____

Operating Conditions

Cooling Mode

Heating Mode

Entering / Leaving Air Temp	_____ / _____	_____ / _____
Entering Air Measured at:	_____	_____
Leaving Air Measured at:	_____	_____
Entering / Leaving Fluid Temp	_____ / _____	_____ / _____
Fluid Flow (gpm)	_____	_____
Compressor Volts / Amps	_____ / _____	_____ / _____
Blower Motor Volts / Amps	_____	_____
Source Fluid Types	_____	_____
Fluid Flow (gpm)*	_____	_____
Fluid-Side Pressure Drop*	_____	_____
Suction / Discharge Pressure (psig)*	_____ / _____	_____ / _____
Suction / Discharge Temp*	_____ / _____	_____ / _____
Suction Superheat*	_____	_____
Entering TXV / Cap Tube Temp*	_____	_____
Liquid Subcooling*	_____	_____

* Required for Troubleshooting ONLY

Auxiliary Heat (If Equipped)

Unit Make _____
 Model Number _____ Serial Number _____
 Max Fuse Size (Amps) _____
 Volts / Amps _____
 Entering Air Temperature _____
 Leaving Air Temperature _____

WIRING DIAGRAMS

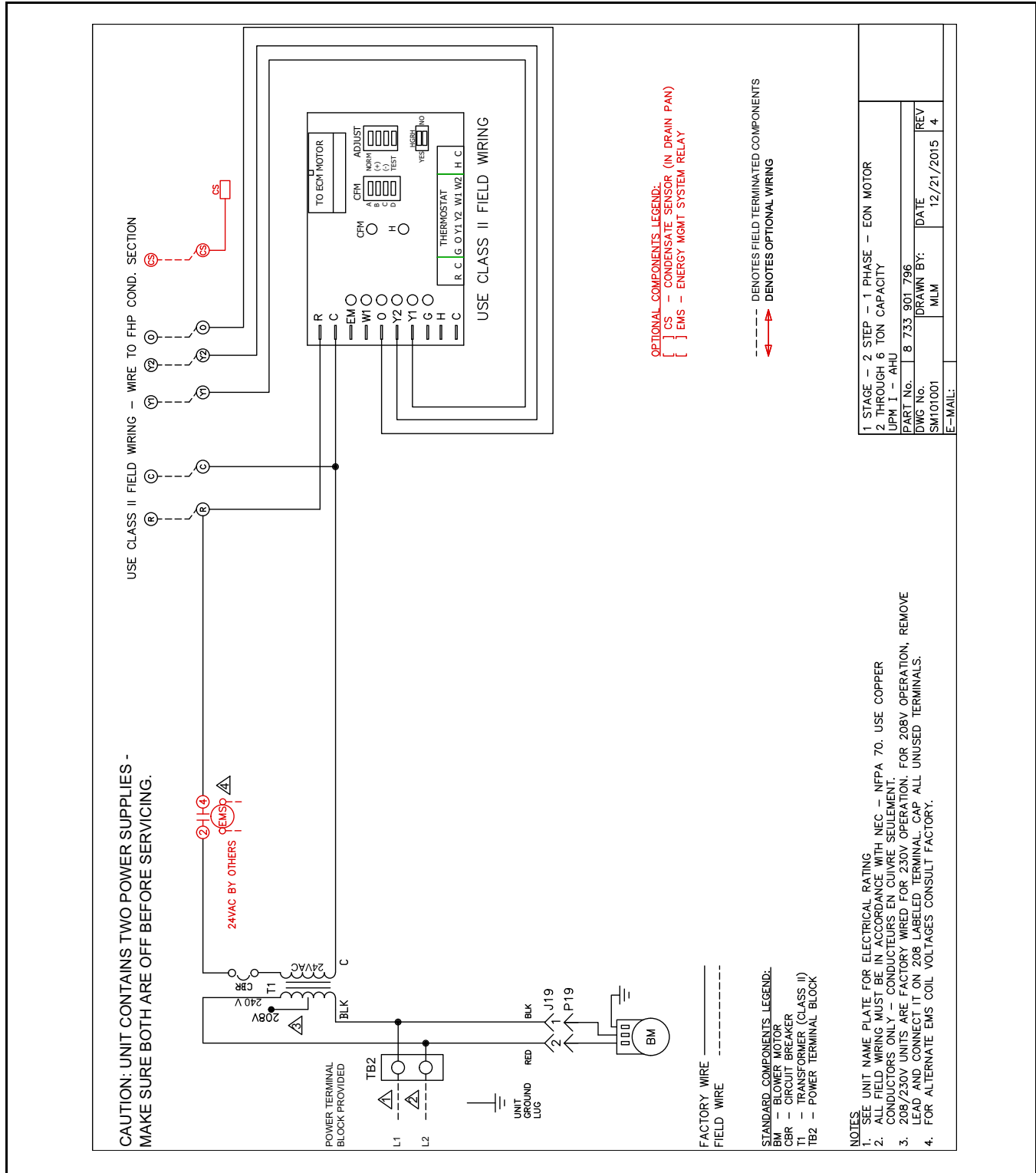

Fig. 15 LM - Wiring Diagram



FOR REFERENCE ONLY Actual unit wiring may vary from this example. Always refer to the wiring diagram attached to the unit.

DIMENSIONAL DRAWINGS

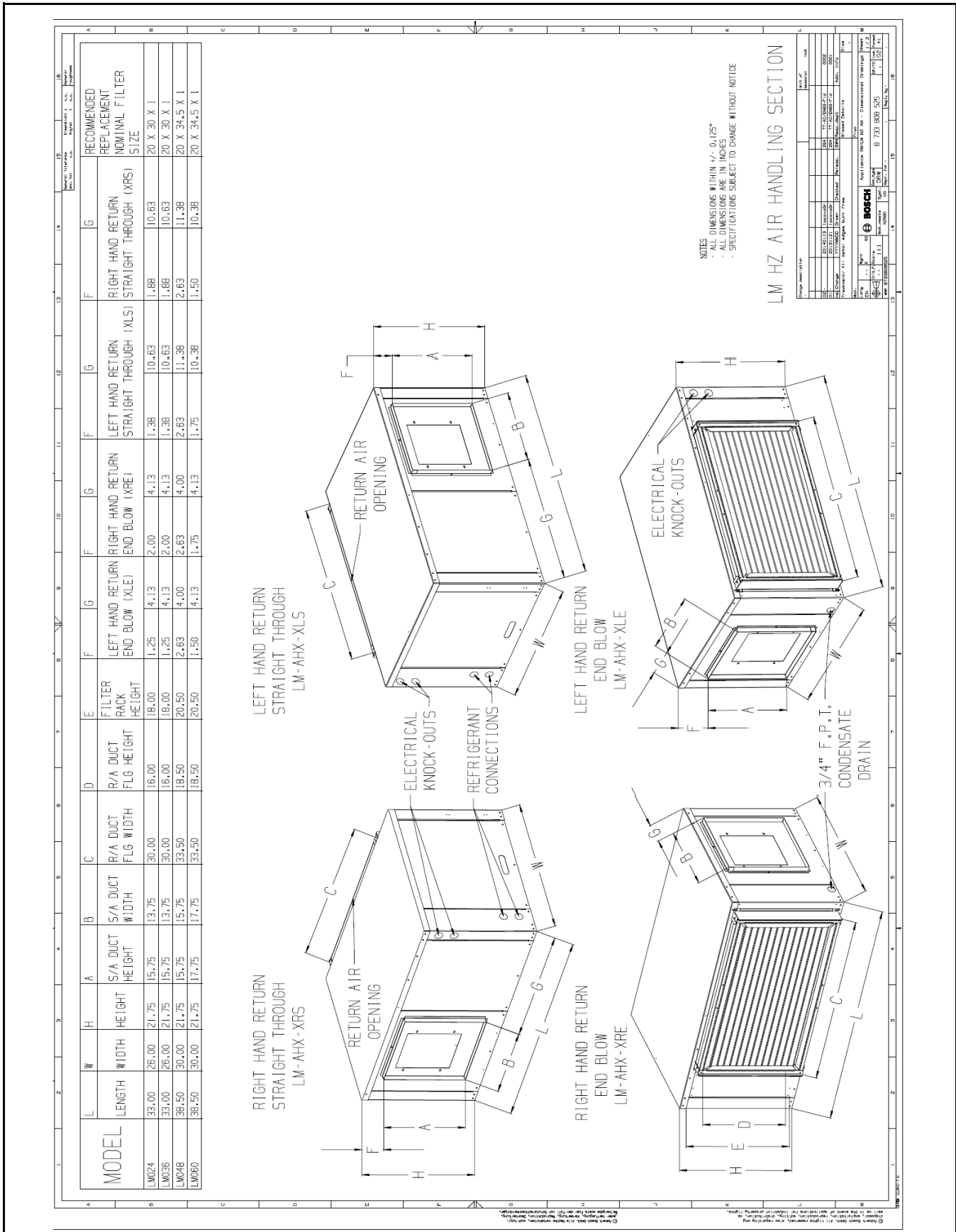

Fig. 16 LMHZ Air Handling Section

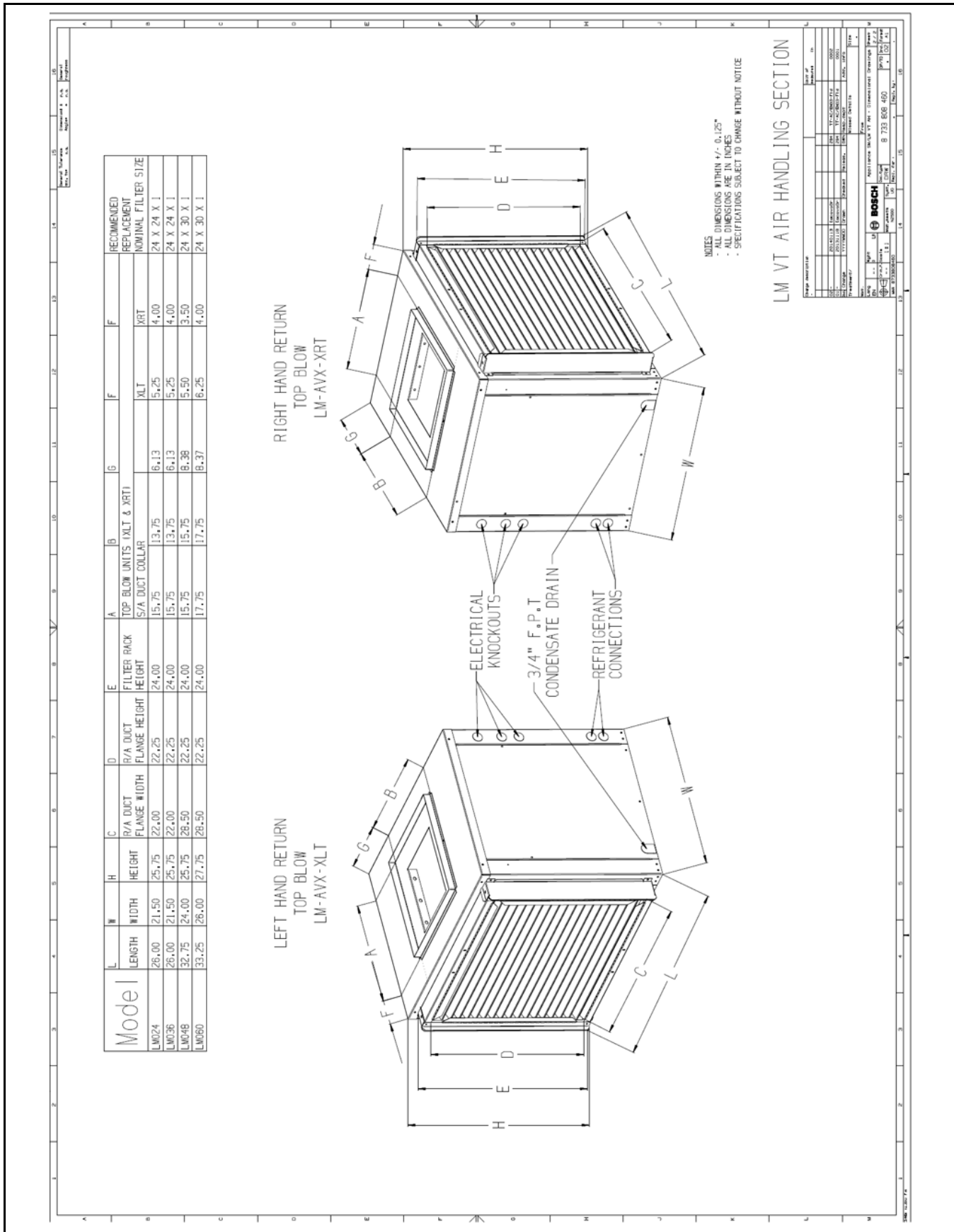

Fig. 17 LM VT Air Handling Section

TERMINOLOGY

Acronyms

AHJ – Authority Having Jurisdiction

AWG – American Wire Gauge

ECM – Electronically Commutated Motor

FLA – Full Load Amps

GLP – Ground Loop Pumping Package

HP – Heat Pump or Horse Power when referring to a motor

LED – Light Emitting Diode

LRA – Locked Rotor Amps

NPA – Name Plate Amps

RLA – Running Load Amps

TXV – Thermal Expansion Valve

UPM – Unit Protection Module

Terms

Conditioned space – Space within a building provided with heated or cooled air or both (or surfaces) and, where required, with humidification or dehumidification means to maintain conditions for an acceptable thermal environment.

Decommissioning – Means the final shut-down and removal from operation or usage of a product or piece of equipment containing fluorinated greenhouse gases.

Discharge Pressure – Referring to the pressure leaving compressor.

Reclamation – Means the reprocessing of a recovered fluorinated greenhouse gas in order to match the equivalent performance of a virgin substance, taking into account its intended use.

Recovery – Referring to the collection and storage of fluorinated-greenhouse gases from products (including containers and equipment) during maintenance or servicing or prior to the disposal of the products or equipment.

Recycling – Referring to the reuse of a recovered fluorinated-greenhouse gas following a basic cleaning process.

Repair – Referring to the restoration of damaged or leaking products or equipment that contain, or whose functioning relies upon, fluorinated-greenhouse gases, involving a part containing or designed to contain such gases.

Suction Pressure – Referring to the pressure entering compressor.

NOTES

NOTES

NOTES

NOTES



BOSCH

Bosch Thermotechnology Corp.

65 Grove Street, Watertown, MA 02472

Phone: +1 (800) 283-3787 | Fax: +1 (603) 965-7568

www.bosch-climate.us.com

Revised 06/2020

8733826257

