

LM Series Heat Pump



LM024 | LM036 | LM048 | LMO60 | LM070



BOSCH

Installation, Operation and Maintenance Manual

8 733 905 315 (2013/9)

CONTENTS

Standard package	4
General Description	4
Moving and Storage	5
Initial Inspection	5
Location	5
Blower Configurability	5
Return and Discharge Duct Flanges	6
Mounting Vertical Units	6
Mounting horizontal Units	6
Condensate Drain	7
Duct System	7
Piping	8
Electrical	8
Safety Devices and the UPM Controller	10
ECM INTERFACE BOARD- Constant Airflow Motor (Option) ..	13
Dehumidification Method Selector	14
Constant Torque Motors (ECM)	14
Options	15
Hot Gas Reheat (HGRH)	15
Electric Heat	15
Constant Airflow Motor	15
Fan Status Switch	15
Pump Status Switch	15
DPS Water Flow Proving	16
Valve End Switch	16
Pump Relay.....	16
Sequence of Operation	16
Cooling Mode	16
Heating Mode.....	16
Application Considerations	18
Cooling Tower/Boiler Systems	18
Geothermal Systems	20
System Checkout	21
Unit Start-up	21
Maintenance	21
Access to Internal Components for Vertical (VT) Units	22
Unit Check-Out Sheet	23
Customer Data	23
Unit Nameplate Data	23
Operating Conditions	23
Auxiliary Heat	23

Troubleshooting	24
Electronic Thermostat Installation	29
Operating Temperatures and Pressures	30
Airflow Tables	35
Wiring Diagrams	37
WIRING HARNESS DRAWINGS	50
Dimensional Drawings	54
Horizontal - Straight Through	55
Horizontal - Hanging bracket location	56
Vertical	57
Notes	58

STANDARD PACKAGE

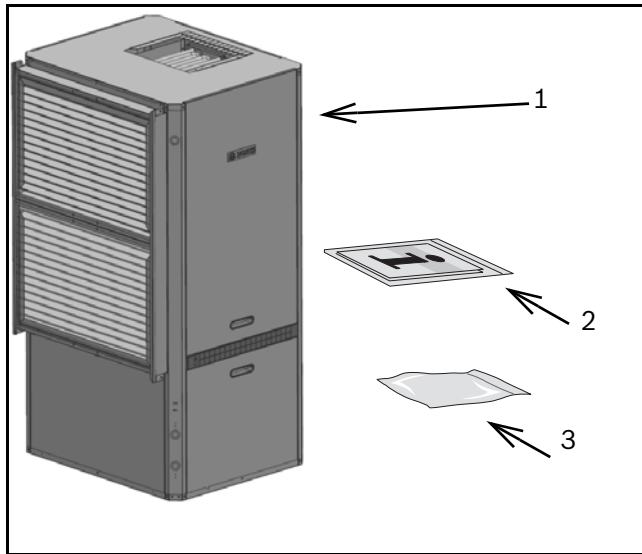

Figure # 1

- [1] LM Series Water-to-Air Heat Pump
- [2] Installation and Operation Manual
- [3] Hanging Bracket Kit (Hz Units Only)

GENERAL DESCRIPTION

LM Series Water-to-Air Heat Pumps provide the best combination of performance and efficiency available. All units are performance certified to American Heating and Refrigeration Institute (AHRI) ISO Standard 13256-1. All LM Water-to-Air Heat Pumps conform to UL1995 standard and are certified to CAN/CSA C22.1 No 236 by Intertek-ETL.

The Water-to-Air Heat Pumps are designed to operate with entering fluid temperature between 20°F to 90°F in the heating mode and between 30°F to 120°F in the cooling mode.



50° Minimum Entering Water Temperature (EWT) for well water applications with sufficient water flow to prevent freezing. Antifreeze solution is required for all closed loop applications. Cooling Tower/Boiler and Geothermal applications should have sufficient antifreeze solution to protect against extreme conditions and equipment failure. Frozen water coils are not covered under warranty. Other equivalent methods of temperature control are acceptable.

LM Series Water-to-Air Heat Pumps are available in Vertical (VT) and Horizontal (HZ) configurations. VT and HZ units Discharge Air Orientation is Field Configurable with the purchase of a separate kit.

Several factory installed options are available:

Hot Gas Reheat, Electric Heat, Sound Package, Smart Start, Constant Airflow Blower Motor, 2" 4-sided filter racks, MERV 8 & 13 filters, Differential Pressure Switch (DPS) Water Flow Proving Switch, Auxiliary Pump Relay, Air Flow Proving Sensor, Zone Valve and Internal Water Pump. See Pg#15 for more detail.



Electric Heat is available as a factory installed option **ONLY**.

Safety devices are built into each unit to provide the maximum system protection possible when properly installed and maintained. Each unit has an external LED error code display, allowing unit diagnosis without opening the cabinet.

Basic Horizontal Unit layout and connections are shown in Figure #2 . For more detail on both the Vertical and Horizontal units, refer to the Dimensional Drawings on Pg#55 through Pg#58.

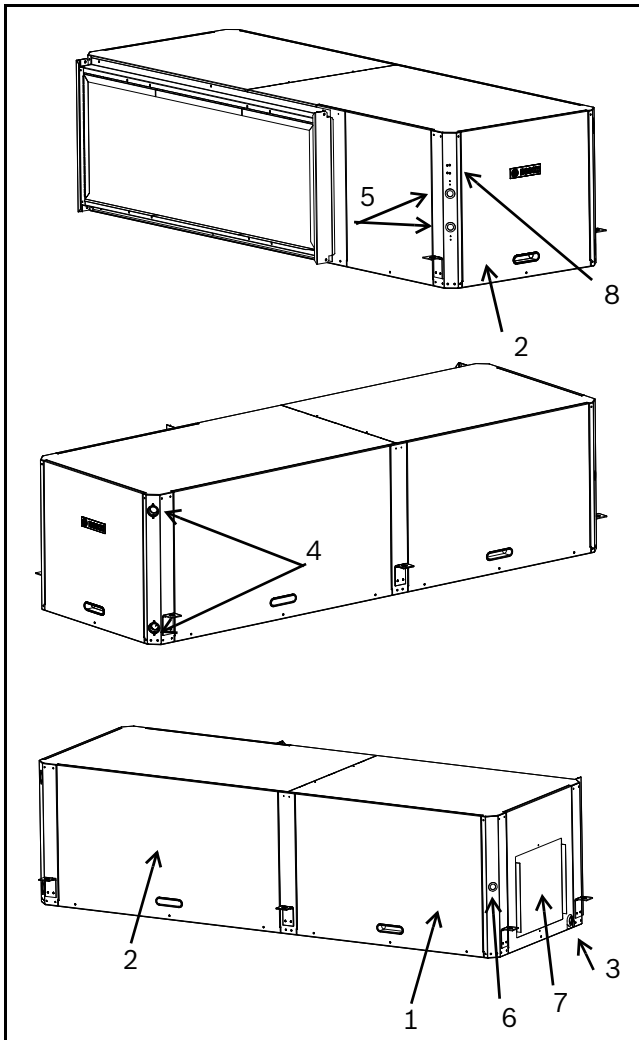

Figure # 2 Left-Hand Unit (Right-Hand Unit is opposite view)

- [1] Air handler access panel
- [2] Condensing section access panel
- [3] Condensate drain connection
- [4] Water connection
- [5] Electrical connection knockout
- [6] Electric Heat electrical connection knockout (Optional)
- [7] Blower outlet (Supply Air)
- [8] LED Error Code

MOVING AND STORAGE

If the equipment is not needed for immediate installation upon its arrival at the job site, it should be left in its shipping carton and stored in a clean, dry area. Units must only be stored or moved in the normal upright position as indicated by the “UP” arrows on each carton at all times.



For storage If unit stacking is required, stack units as follows:

Do not stack 6 ton units!

Vertical units: less than 6 tons, no more than two high.

Horizontal units: less than 6 tons, no more than three high.

INITIAL INSPECTION

Be certain to inspect all cartons or crates on each unit as received at the job site before signing the freight bill. Verify that all items have been received and that there are no visible damages; note any shortages or damages on all copies of the freight bill. In the event of damage or shortage, remember that the purchaser is responsible for filing the necessary claims with the carrier. Concealed damages not discovered until after removing the units from the packaging must be reported to the carrier within 24 hours of receipt.

LOCATION

Locate the unit in an indoor area that allows easy removal of the filter and access panels, with enough room for service personnel to perform maintenance or repair. Provide sufficient room to make fluid, electrical, and duct connection(s). If the unit is located in a confined space such as a closet, provisions must be made for return air to freely enter the face of unit’s air coil. On horizontal units, allow adequate room below the unit for a condensate drain trap and do not locate the unit above supply piping.



These units are not approved for outdoor installation; therefore, they must be installed inside the structure being conditioned. Do not locate in areas that are subject to freezing.

BLOWER CONFIGURABILITY

To change configuration of the LM unit requires the purchase of a separate Blower panel Conversion Kit. Please refer to the **Spare Parts List_8733911143** (On website www.fhp-mfg.com) and the **Blower Configurability IM_8733911121**.

RETURN AND DISCHARGE DUCT FLANGES

Return and discharge opening duct flanges are shipped unfolded. Flanges bend lines are perforated allowing easy bending using standard sheet metal pliers or channel locks. (Figure #3)



Bend flanges **one at a time**, using standard sheet metal pliers or channel locks.

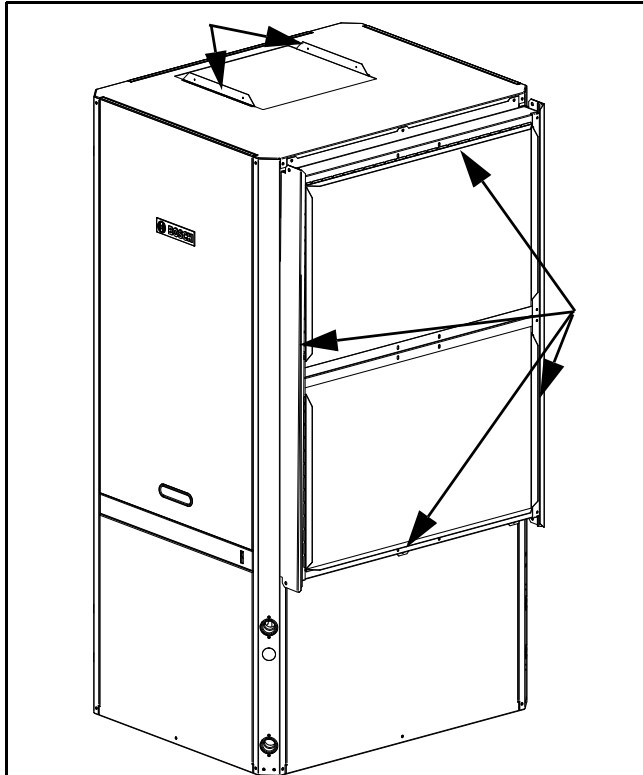

Figure # 3

MOUNTING VERTICAL UNITS

Vertical units should be mounted level on a vibration absorbing pad slightly larger than the base to minimize vibration transmission to the building structure. It is not necessary to anchor the unit to the floor. (Figure #4).



On VT Units Condensate Drain pan is internally sloped. There is no internal P-Trap.

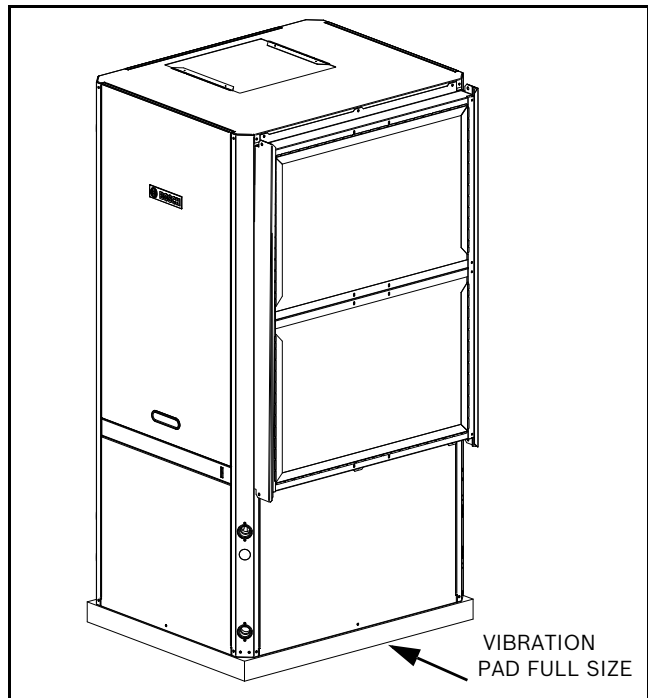

Figure # 4

MOUNTING HORIZONTAL UNITS

While horizontal units may be installed on any level surface strong enough to hold their weight, they are typically suspended above a ceiling by threaded rods. The manufacturer recommends these be attached to the unit corners by hanger bracket kits. The rods must be securely anchored to the ceiling. Refer to the hanging bracket assembly and installation instructions for details.



Horizontal units installed above the ceiling must conform to all local codes. An auxiliary drain pan if required by code, should be at least four inches larger than the bottom of the heat pump.

Plumbing connected to the heat pump must not come in direct contact with joists, trusses, walls, etc. Some applications require an attic floor installation of the horizontal unit. In this case the unit should be set in a full size secondary drain pan on top of a vibration absorbing mesh.

The Secondary drain pan prevents possible condensate overflow or water leakage damage to the ceiling.

The secondary drain pan is usually placed on a plywood base isolated from the ceiling joists by additional layers of vibration absorbing mesh. In both cases, a 3/4" drain connected to this secondary pan should be run to an eave at a location that will be noticeable.

If the unit is located in a crawl space, the bottom of the unit must be at least 4" above grade to prevent flooding of the electrical parts during heavy rains.



Horizontal (HZ) units must be installed pitched toward the Condensate Drain Connection 1/8" per foot.

CONDENSATE DRAIN

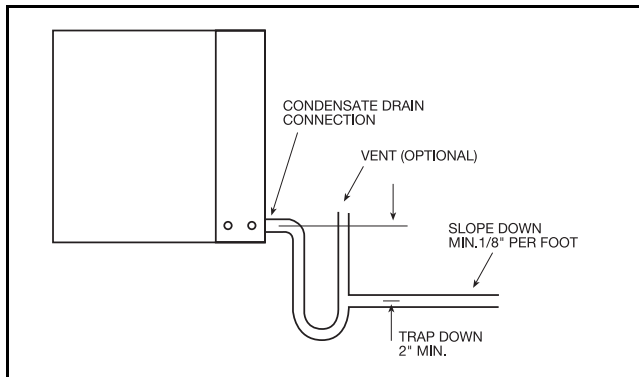

Figure # 5

A drain line must be connected to the heat pump and pitched away from the unit a minimum of 1/8" per foot to allow the condensate to flow away from the unit.

This connection must be in conformance with local plumbing codes. A trap must be installed in the condensate line to insure free condensate flow.



HZ Heat Pump Drain Pan is not internally sloped.

A vertical air vent is sometimes required to avoid air pockets. The length of the trap depends on the amount of positive or negative pressure on the drain pan. A second trap must not be included.

DUCT SYSTEM

A supply air outlet collar and return air duct flange are provided on all units to facilitate duct connections.



Supply air duct and return air duct flanges are shipped unfolded with unit.

Fold the duct flange outwards along the perforated line. Refer to unit Dimensional Drawings for physical dimensions of the collar and flange. (Pg#55 through Pg#58)

A flexible connector is recommended for supply and return air duct connections on metal duct systems. All metal ducting should be insulated with a minimum of one inch duct insulation to avoid heat loss or gain and prevent condensate forming during the cooling operation. Application of the unit to uninsulated duct work is not recommended as the unit's performance will be adversely affected.



Do not connect discharge ducts directly to the blower outlet.

The factory provided air filter must be removed when using a filter back return air grill. The factory filter should be left in place on a free return system.

If the unit will be installed in a new installation which includes new duct work, the installation should be designed using current ASHRAE procedures for duct sizing. If the unit is to be connected to existing duct work, a check should be made to assure that the duct system has the capacity to handle the air required for the unit application. If the duct system is too small, larger duct work should be installed. Check for existing leaks and repair.

The duct system and all diffusers should be sized to handle the designed air flow quietly. To maximize sound attenuation of the unit blower, the supply and return air plenums should be insulated. There should be no direct straight air path thru the return air grille into the heat pump. The return air inlet to the heat pump must have at least one 90 degree turn away from the space return air grille. If air noise or excessive air flow are a problem, the blower speed can be changed to a lower speed to reduce air flow.

PIPING

Supply and return piping must be as large as the unit connections on the heat pump (larger on long runs).



Never use flexible hoses of a smaller inside diameter than that of the fluid connections on the unit.

LM units are supplied with either a copper or optional cupro-nickel condenser. Copper is adequate for ground water that is not high in mineral content.



Proper testing is recommended to assure the well water quality is suitable for use with water source equipment.

In conditions anticipating moderate scale formation or in brackish water a cupro-nickel heat exchanger is recommended.

Both the supply and discharge water lines will sweat if subjected to low water temperature. These lines should be insulated to prevent damage from condensation. All manual flow valves used in the system must be ball valves. Globe and gate valves must not be used due to high pressure drop and poor throttling characteristics.



Never exceed the recommended water flow rates, as serious damage or erosion of the water-to-refrigerant heat exchanger could occur.

Always check carefully for water leaks and repair appropriately. Units are equipped with female pipe thread fittings. Consult Unit Dimensional Drawings. (Pg#55 through Pg#58)



Teflon tape sealer should be used when connecting water piping connections to the units to insure against leaks and possible heat exchanger fouling.



Do not overtighten the connections.

Flexible hoses should be used between the unit and the rigid system to avoid possible vibration. Ball valves should be installed in the supply and return lines for unit isolation and unit water flow balancing.

ELECTRICAL

Refer to electrical component box layout. (Figures #6-8)



Field wiring must comply with local and national electric codes.



Power to the unit must be within the operating voltage range indicated on the unit nameplate or on the performance data sheet.



Operation of unit on improper line voltage or with excessive phase imbalance will be hazardous to the unit, constitutes abuse and may void the warranty.

Properly sized fuses or HACR circuit breakers must be installed for branch circuit protection. See unit nameplate for maximum fuse or breaker size.

The unit is provided with a concentric knock-out for attaching common trade sizes of conduit, route power supply wiring through this opening.

Always connect the ground lead to the grounding lug provided in the control box and power leads to the line side of compressor contactor as indicated on the wiring diagram (Figures#25 through #31, Pg#38 through Pg#47).



Units supplied with internal electric heat require two (2) separate power supplies:

- 1) Unit compressor
- 2) Electric Heat, Blower Motor and Control Circuit.

Refer to the ELECTRIC HEATER PACKAGE OPTION section and Pg#38 through Pg#47 for wiring diagrams. See data plate for minimum circuit ampacities and maximum fuse/breaker sizing.

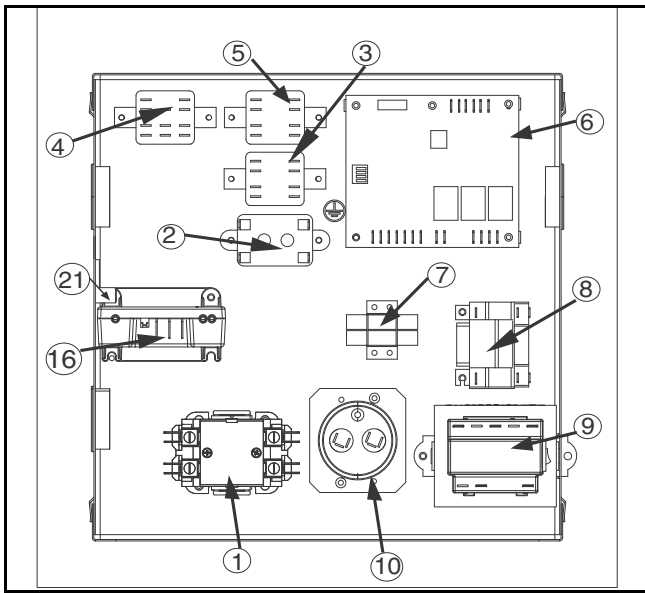

Figure # 6 - Single Phase Unit

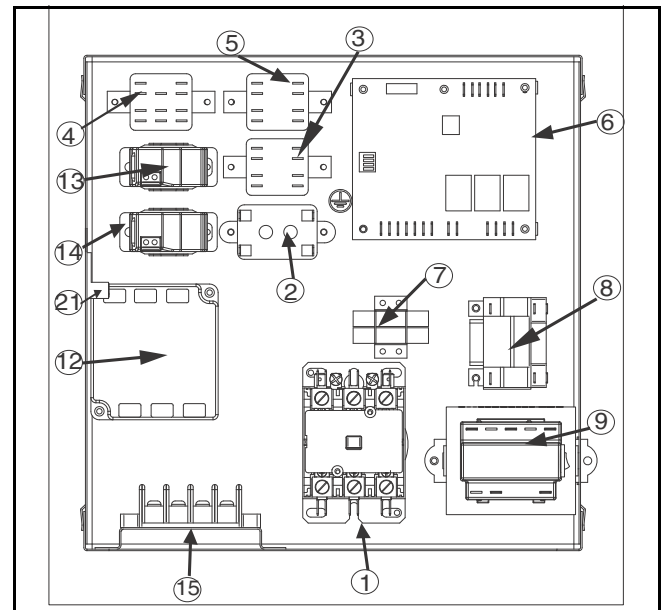

Figure # 8 Three Phase Unit

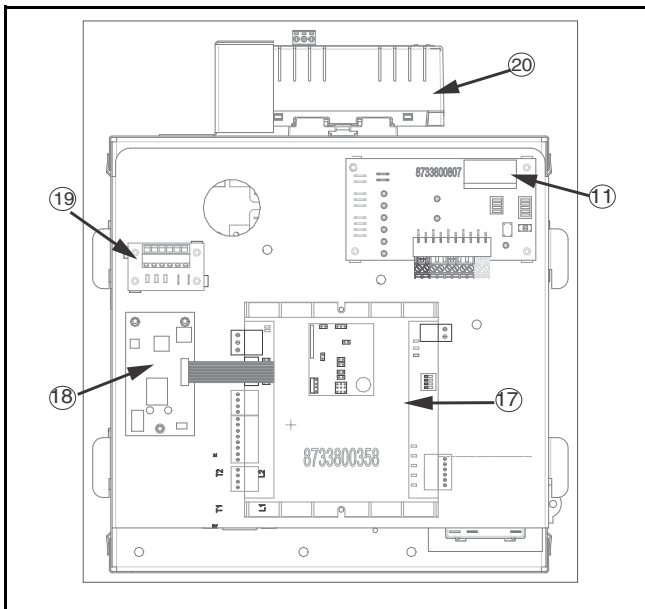

Figure # 7 EBox Cover

- [1] Compressor contactor
- [2] Emergency Relay (Option)
- [3] Second Stage Relay
- [4] Hot Gas Reheat Relay (Option)
- [5] Cooling Relay
- [6] Unit Protection Module (UPM)
- [7] Terminal block Low-Voltage
- [8] Auxiliary Relay (Option)
- [9] Transformer
- [10] Capacitor
- [11] ECM Interface Board (Option, mounts on E-Box cover)
- [12] Phase Monitor
- [13] Fan Status Switch (Option)
- [14] Pump Status Switch (Option)
- [15] Terminal Block 460V Units (Option)
- [16] Comfort Alert Module (Option)
- [17] DDC (Option)
- [18] LonWorks Card (Option)
- [19] Input Expansion Module (Option)
- [20] Smart Start Assist (Option)
- [21] Ground Lug

Safety Devices and the UPM Controller

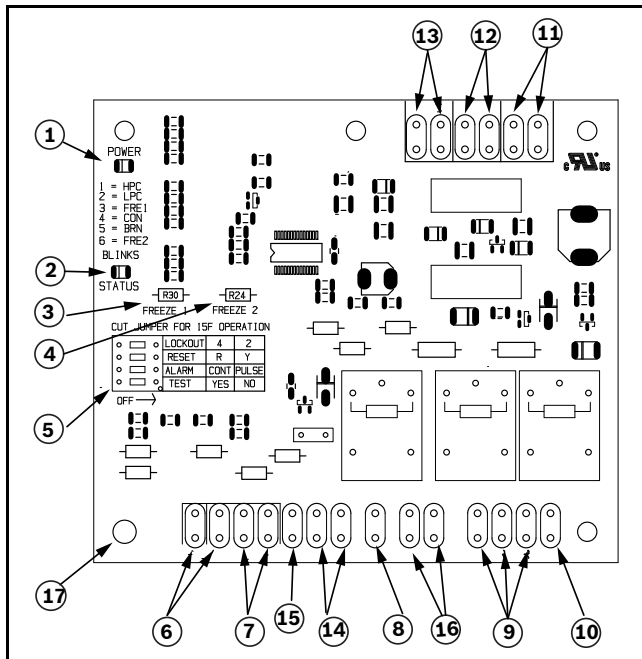

Figure # 9

- [1] Board Power Indicator
- [2] UPM Status LED Indicator
- [3] Water Coil Freeze Protection Temperature Selection [R30]
- [4] Air Coil Freeze Protection Temperature Selection
- [5] UPM Board Settings
- [6] Water Coil Freeze Connection
- [7] Air Coil Freeze Connection
- [8] LED Status-Diagnostic Connection
- [9] 24VAC Power Input
- [10] Compressor Contact Output
- [11] High Pressure Switch Connection
- [12] Call for Compressor Y1
- [13] Low Pressure Switch Connection
- [14] 24VAC Power Common
- [15] Condensate Overflow Sensor
- [16] Dry Contact
- [17] UPM Ground Standoff



If the unit is being connected to a thermostat with a malfunction light, this connection is made at the unit malfunction output or relay. Refer to Figure #9.



If the thermostat is provided with a malfunction light powered off of the common (C) side of the transformer, a jumper between “R” and “COM” terminal of “ALR” contacts must be made.



If the thermostat is provided with a malfunction light powered off of the hot (R) side of the transformer, then the thermostat malfunction light connection should be connected directly to the (ALR) contact on the unit’s UPM board.

Each unit is factory provided with a Unit Protection Module (UPM) that controls the compressor operation and monitors the safety controls that protect the unit.

Safety controls include the following:

- High pressure switch located in the refrigerant discharge line and wired across the HPC terminals on the UPM
- Low pressure switch located in the unit refrigerant suction line and wired across terminals LPC1 and LPC2 on the UPM.



UPM Board Dry Contacts are Normally Open (NO)

- Water side freeze protection sensor, mounted close to condensing water coil, monitors refrigerant temperature between condensing water coil and thermal expansion valve. If temperature drops below or remains at freeze limit trip for 30 seconds, the controller will shut down the compressor and enter into a soft lockout condition. The default freeze limit trip is 30°F, however this can be changed to 15°F by cutting the R30 or Freeze1 resistor located on top of DIP switch SW1. Refer to Figure #9, item [3] for resistor location. (Refer to Figure #10 for sensor location)

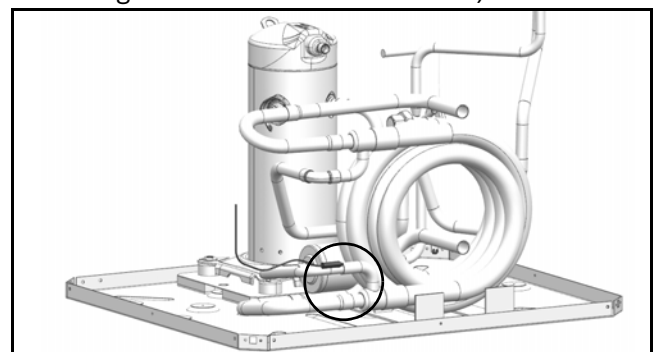

Figure # 10



If unit is employing a fresh water system (no anti-freeze protection), it is extremely important to have the Freeze1 R30 resistor set to 30°F in order to shut down the unit at the appropriate leaving water temperature and protect your heat pump from freezing if a freeze sensor is included.

- Evaporator freeze protection sensor, mounted between the thermal expansion device and the evaporator, monitors refrigerant temperature between the evaporator coil and thermal expansion valve. If temperature drops below or remains at freeze limit trip for 30 seconds, the controller will shut down the compressor and enter into a soft lockout condition. The default freeze limit trip is 30°F. (Figure#11)

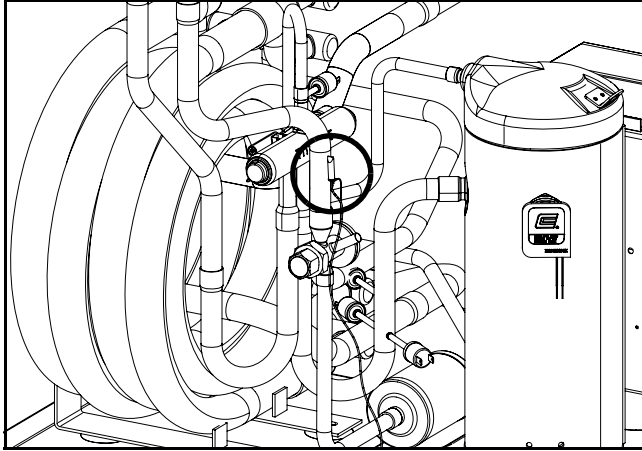

Figure # 11

- The condensate overflow protection sensor is located in the drain pan of the unit and connected to the 'COND' terminal on the UPM board. (Figure #)

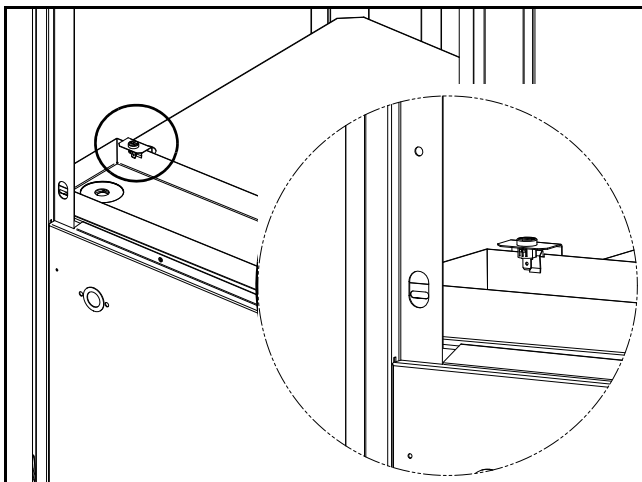

Figure # 12

UPM Board Factory Default Settings

TEMP	30°F
LOCKOUT	2
RESET	Y
ALARM	PULSE
TEST	NO

UPM DIP SWITCH DEFAULT POSITION

<input type="checkbox"/>	lockout	4	2
<input type="checkbox"/>	reset	R	Y
<input type="checkbox"/>	alarm	Cont	pulse
<input type="checkbox"/>	test	yes	no

The UPM Board includes the following features:

- ANTI-SHORT CYCLE TIMER:** 5 minute delay on break timer to prevent compressor short cycling.
- RANDOM START:** Each controller has an unique random start delay ranging from 270 to 300 seconds on initial power up to reduce the chance of multiple unit simultaneously starting at the same time after power up or after a power interruption, thus avoiding creating large electrical spike.
- LOW PRESSURE BYPASS TIMER:** If the compressor is running and the low pressure switch opens, the controller will keep the compressor ON for 120 seconds. If, after 120 seconds the low pressure switch remains open, the controllers will shut down the compressor and enter a soft lockout. The compressor will not be energized until the low pressure switch closes and the anti-short cycle time delay expires. If the low pressure switch opens 2-4 times in 1 hour, the unit will enter a hard lockout. In order to exit hard lockout power to the unit would need to be reset.
- BROWNOUT/SURGE/POWER INTERRUPTION PROTECTION:** The brownout protection in the UPM board will shut does the compressor if the incoming power falls below 18 VAC. The compressor will remain OFF until the voltage is above 18 VAC and ANTI-SHORT CYCLE TIMER (300 seconds) times out. The unit will not go into a hard lockout.

- **MALFUNCTION OUTPUT:** Alarm output is Normally Open (NO) dry contact. If pulse is selected the alarm output will be pulsed. The fault output will depend on the dip switch setting for "ALARM". If it is set to "CONST", a constant signal will be produced to indicate a fault has occurred and the unit requires inspection to determine the type of fault. If it is set to "PULSE", a pulse signal is produced and a fault code is detected by a remote device indicating the fault. See LED Fault Indication below for blink code explanation. The remote device must have a malfunction detection capability when the UPM board is set to "PULSE".



If 24 VAC output is needed R must be wired to ALR-COM terminal; 24 VAC will be available on the ALR-OUT terminal when the unit is in the alarm condition.

- **LED ANNUNCIATOR:** This LED kit provides a quick visual indication of whether or not a heat pump is energized and if it has locked out on a fault. The LED kit is mounted to the electrical corner post of the heat pump and employs high intensity LED's for better visibility. The LED kit will exactly mirror the LED blink codes on the UPM board (refer to the blink code table in the UPM sequence of operation).
- **TEST DIP SWITCH:** A test dip switch is provided to reduce all time delays settings to 10 seconds during troubleshooting or verification of unit operation.



Operation of unit in test mode can lead to accelerated wear and premature failure of components. The "TEST" switch must be set back to "NO" after troubleshooting/servicing.

- **FREEZE SENSOR:** The default setting for the freeze limit trip is 30°F (sensor number 1); however this can be changed to 15°F by cutting the R30 resistor located on top of the DIP switch SW1. The default setting for the freeze limit trip is 30°F (sensor number 1); however this can be changed to 15°F by cutting the R24 resistor located on top of the DIP switch SW1. Since freeze sensor 2 is dedicated to monitor the evaporator coil it is recommended to leave the factory default setting on the board. The UPM controller will constantly monitor the refrigerant temperature with the sensor mounted close to the condensing water coil

between the thermal expansion valve and water coil. If temperature drops below or remains at the freeze limit trip for 30 seconds, the controller will shut the compressor down and enter into a soft lockout condition. Both the status LED and the Alarm contact will be active. The LED will flash (three (3) times) the code associated with this alarm condition. If this alarm occurs 2 times (or 4 if Dip switch is set to 4) within an hour the UPM controller will enter into a hard lockout condition. It will constantly monitor the refrigerant temperature with the sensor mounted close to the evaporator between the thermal expansion valve and evaporator coil as shown in Figure #5. If temperature drops below or remains at the freeze limit trip for 30 seconds, the controller will shut the compressor down and enter into a soft lockout condition. Both the status LED and the Alarm contact will be active. The LED will flash (three (6) times) the code associated with this alarm condition. If this alarm occurs 2 times (or 4 if Dip switch is set to 4) within an hour the controller will enter into a hard lockout condition.

Refer to page #10 for more information.



Freeze sensor will not guard against loss of water. Flow switch is recommended to prevent unit from running, if water flow is lost or reduced.

- **INTELLIGENT RESET:** If a fault condition is initiated, the 5 minute delay on break time period is initiated and the unit will restart after these delays expire. During this period the fault LED will indicate the cause of the fault. If the fault condition still exists or occurs 2 or 4 times (depending on 2 or 4 setting for Lockout dip switch) before 60 minutes, the unit will go into a hard lockout and requires a manual lockout reset. A single condensate overflow fault will cause the unit to go into a hard lockout immediately, and will require a manual lockout reset.
- **LOCKOUT RESET:** A hard lockout can be reset by turning the unit thermostat off and then back on when the "RESET" dip switch is set to "Y" or by shutting off unit power at the circuit breaker when the "RESET" dip switch is set to "R".



The blower motor will remain active during a lockout condition.

ECM INTERFACE BOARD- Constant Airflow Motor (Option)

Refer to Figure #9, item [12] for ECM interface board location. In addition to providing a connecting point for thermostat wiring, the interface board also translates thermostat inputs into control commands for the Electronic Commutated Motor (ECM) DC fan motor and provides thermostat signals to unit's UPM board. The thermostat connections and their functions are as follows:

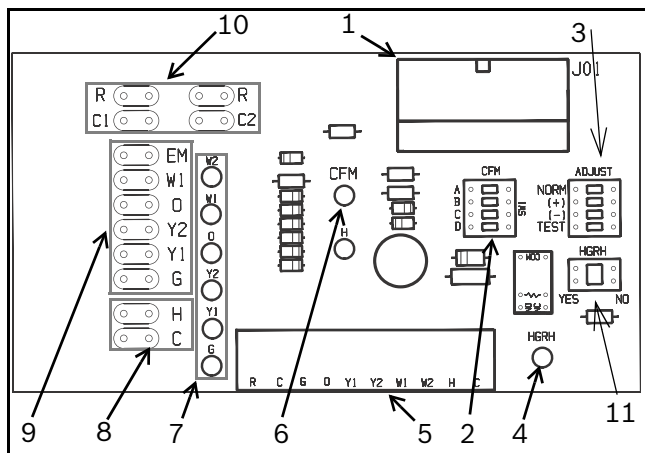

Figure # 13

- [1] Motor harness plug
- [2] Blower CFM adjustment
- [3] Motor settings
- [4] Dehumidification indication
- [5] Thermostat digital contact inputs
- [6] CFM count indicator
- [7] Thermostat input status indication
- [8] Reheat digital outputs
- [9] Thermostat outputs
- [10] 24 VAC
- [11] Dehumidification method selector



CFM LED indication is an approximation. Utilize conventional Test and Balance equipment for accurate airflow measurement.

- CFM count indicator (See Figure #13, item [6]) blinks to indicate approximate airflow in CFM and may flicker when unit is off.
- Each blink of the LED represent approximately 100 CFM of air delivery so if the LED blinks 12 times, pauses, blinks 12 times, etc. the blower is delivering approximately 1200 CFM.

Thermostat Outputs

Y1	First Stage Compressor Operation
Y2	Second Stage Compressor Operation
G	Fan
O	Reversing Valve (energized in cooling)
W1	Auxiliary Electric Heat (runs in conjunction with compressor)
EM/W2	Emergency Heat (electric heat only)
NC	Transformer 24 VAC Common (extra connection)
C1	Transformer 24 VAC Common (primary connection)
R	Transformer 24 VAC Hot
H	Dehumidification Mode

Airflow Selector

The airflow selector (Figure #13, items [2] & [3]) allows airflow adjustment to meet application requirements and to ease troubleshooting.



Only one switch can be enabled at a time. Refer to Figure #22 for each airflow setting.

- CFM Selector (Fig #13, Item [2]) must remain with only "A" being enabled.
- ADJUST Selector can be adjusted to NOM, (+), (-), or TEST. NOM, (+) and (-) can be adjusted as needed by application. TEST is used for troubleshooting to override unit airflow to 100%.

ECM CONTROL BOARD FACTORY DEFAULT SETTINGS

CFM



CFM PROFILE SELECTOR.

ONLY ONE SWITCH IS TO BE ENABLED AT A TIME.

PROFILES PROGRAMMED IN THE MOTOR REFER TO AIRFLOW PROFILE TABLES IN IOM. FACTORY DEFAULT IS "A"

ADJUST

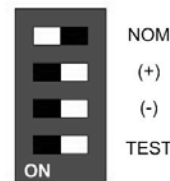

AIRFLOW PERCENT SELECTOR.

ONLY ONE SWITCH IS TO BE ENABLED AT A TIME.

PERCENTAGES PROGRAMMED IN THE MOTOR. REFER TO AIRFLOW TABLE IN IOM. TYPICALLY "+" = 15% INCREASE IN AIRFLOW



Do not set the ADJ DIP switch to the (-) setting when electric heaters are installed. Doing so may cause the heaters to cycle on their thermal overload switches, potentially shortening the life of the switches.



Always disconnect power before changing DIP Switch position on the interface board and reset the unit afterward.

Dehumidification Method Selector

Dehumidification method selector (Figure #13, item [11]) is used to select between the following two methods:

- 1) Units equipped with optional Hot Gas Reheat, on dehumidification call (the “H” terminal on the thermostat is energized) the reheat outputs will energize the hot gas reheat valve in the circuit and the heat pump will start in dehumidification mode.
Dehumidification selector (Figure #13, item [11]) should be selected to ‘YES’.
2. Units without optional Hot Gas Reheat, on dehumidification call, the heat pump fan will operate at a lower speed to increase dehumidification while cooling.
Dehumidification selector ((Figure #13, item [11]) should be selected to ‘NO’.



In this mode, the heat pump will only dehumidify the space when it is running in cooling mode.

Dehumidification indicator LED (Figure #13, item [4]) will energize when dehumidification call is present.

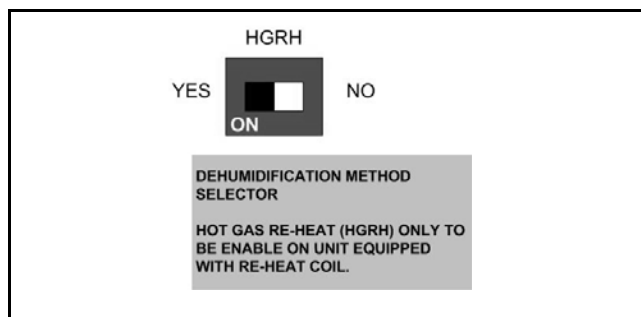

To the left of the red and green status LED's is a row of 1/4" male quick connects. These are used to pass thermostat inputs on to the rest of the control circuit. Remember to always turn off unit power at the circuit breaker before attaching or disconnecting any wiring from these connections to avoid accidental short circuits that can damage unit control components.

CONSTANT TORQUE MOTORS (ECM)

For installations where the efficiency of an electronically commutated brushless DC motor (ECM) motor is required, but the features of a constant airflow motor are not required, the LM series comes standard with the constant torque ECM motor option. These motors feature up to 90% thermal efficiency combined with a flatter fan curve than a PSC motor and simple operation. These motors are provided with 5 speed taps to allow for a wide range of air flow and external static options.

To change a speed tap follow the instructions below:

1. Disconnect power to the heat pump.
2. Remove the blower access panel.
3. Remove the speed tap wire from the terminal it is currently connected to and connect it to the terminal desired.

Refer to the constant torque motor performance tables for heat pump blower performance with the constant torque motor option. (Pg#35)

OPTIONS

Number of factory installed options are available on LM Series of Heat Pumps. The following details the purpose, function and components of each option.

Hot Gas Reheat (HGRH)

Hot gas reheat is an active dehumidification option available on the LM series that cools and dehumidifies return air, and then reheats it back to approximately entering dry bulb temperature using waste compressor heat. In this way, a unit with Hot Gas Reheat can efficiently remove humidity from the return air without altering the sensible temperature of the space.

The reheat option consists of a refrigerant to air heat exchanger (reheat coil) mounted down stream of the evaporator coil. When there is a signal for dehumidification AND the sensible space temperature is satisfied, the unit will operate in reheat mode. In reheat mode the heat pump will operate at full load cooling and will divert discharge gas from the compressor to the reheat coil, effectively cooling and dehumidifying the air and then reheating it back to a temperature close to the entering dry bulb temperature. If there is a call for sensible cooling while the unit is operating

in the reheat mode, then the unit will revert to cooling until the sensible demand is satisfied.



Heat pumps with hot Gas Reheat need to be connected to a humidistat along with a traditional thermostat or a combination thermostat/humidistat.

Electric Heat

Internally mounted supplemental electric heat is available on select models of the LM series. Electric heating elements can operate along with reverse cycle heating as auxiliary heat or in lieu of reverse cycle heating (refrigeration heating) as emergency backup heat.

Availability matrix, including available nominal kW capacities is shown below:



Internal mounted Electric Heat is only available on top blow vertical cabinets, end blow horizontal cabinet .



Internal electric heat cannot be provided with hot gas reheat. Units with internal electric heat must have 2 field power supplies.

Heater Model	KW		Stgs	Btu/h		Product Series Compatibility				
	208V	230V		208V	230V	LM024	LM036	LM048	LM060	LM070
Kw05-	3.6	4.8	1	12300	16300	x	x	x	x	x
Kw10-	7.2	9.6	2	24600	32700		x	x	x	x
Kw15	10.8	14.4	2	36900	49100			x	x	x
Kw20	14.4	19.2	2	49200	63400				x	x

x available

Constant Airflow Motor

The Constant Airflow Motor is an Electronic Commutated Motor (ECM) that provides a constant air flow over a wide range of external static pressures, while optimizing the power consumption of the motor.

This option allows the unit to have different air flow settings depending on the mode that the unit is operating; i.e heating, cooling, fan only, hot gas reheat, etc.



Please refer to the ECM Interface Board Section (Pg. 14) for more information.

Fan Status Switch

The fan status switch is a Current Transformer (CT) that monitors the current flow to the supply fan motor. It's default is Normally Open (NO) circuit when the motor is not running, and closes once it senses current flow.

Pump Status Switch

The pump status switch is a Current Transformer (CT) that monitors the current flow from the condenser pump motor. It's default is Normally Open (NO) when the motor is not running, and closes once it senses current flow.

DPS Water Flow Proving

The DPS water flow proving switch is a factory installed option available for the LM series. The DPS prevents compressor operation if there is inadequate water flow through the water to refrigerant heat exchanger in the heat pump.

The DPS operates by monitoring the water side pressure drop across the water to the refrigerant heat exchanger. When the pressure drop between the water in and water out lines reaches a pre-set value, compressor operation is enabled.

Valve End Switch

The leaving water valves are all equipped with Valve End Switches (VES) and it is a factory installed option available for the LM series.

The VES prevents compressor operation if the valve is not fully open. This prevents short-cycling due to low water through the water-to-refrigerant heat exchanger in the heat pump.

The VES only closes once the leaving water valve is fully open. The valve is activated by the compressor call (Y1) signal.

Pump Relay

The factory installed pump relay can be used to energize a supply pump or solenoid valve when there is a call for compressor operation. This relay can be used to switch either high or low voltage power.

SEQUENCE OF OPERATION

Cooling Mode

Energizing the “O” terminal energizes the unit reversing valve thus placing the unit into cooling mode. The fan motor starts when the “G” terminal is energized.



The fan motor will take 30 seconds to ramp up to operating speed and will run at fan only rated air flow, as long as there is **no call** for compressor or heater operation.

When the thermostat calls for first stage cooling (Y1) the loop pump or solenoid valve if present is energized and the first stage of compressor capacity starts.



Some options will have a built in delay, and hence, compressor operation is not immediate. See ‘Options’ section for more detail.

When the thermostat calls for second stage cooling (Y2) the second stage (or full compressor capacity) is initiated. The fan ramps up to full cooling air flow.

Once the thermostat is satisfied, the compressor shuts down and the fan ramps down to either fan only mode or off over a span of 30 seconds.



A fault condition initiating a lockout will de-energize the compressor irrespective of which stage is engaged.

Heating Mode

The first two stages of heating (Y1 & Y2) operate in the same manner as cooling, but with the reversing valve de-energized. On a call for auxiliary heat (W1), the fan ramps up to auxiliary heat air flow immediately and the electric heater package is energized along with the compressor. As the thermostat is satisfied, the heaters will shut off as soon as W1 is de-energized, and the compressors will remain on until the thermostat stages are satisfied.



If the unit compressor lock out for any reason at this time, the electric heaters will continue to function normally.

Once the thermostat is satisfied, the compressor shuts down and the fan ramps down either fan only mode or off over a span of 30 seconds. If thermostat has two different output points one for Auxiliary heat and a different one for Emergency heat the two outputs must be terminated on W1 units equipped with one stage of Electric heat. (Figure #14)



When using a 2-cool, 3-heat thermostat both the W1 & W2 on the Heat Pump and W2 & EM on the thermostat must be connected together via a jumper. (See Figure#22)

UPM Sequence of Operation (SOO) Flow Chart

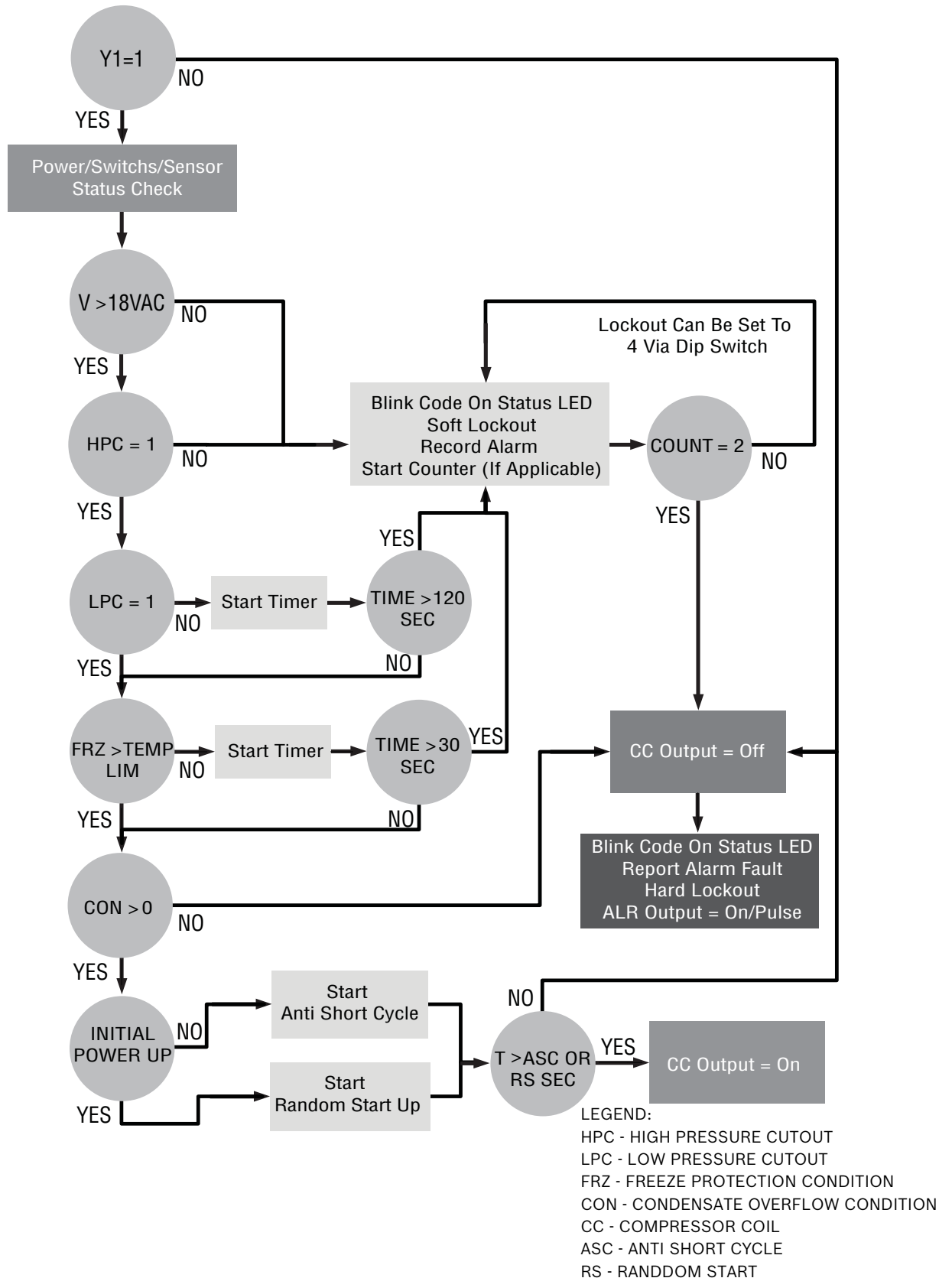

Figure # 14

APPLICATION CONSIDERATIONS

Cooling Tower/Boiler Systems

The cooling tower and boiler water loop temperature is usually maintained between 50° F to 100 ° F to assure adequate cooling and heating performance.

In the cooling mode, heat is rejected from the unit into the water loop. A cooling tower provides evaporative cooling to the loop water thus maintaining a constant supply temperature to the unit. When utilizing open cooling towers, chemical water treatment is mandatory to ensure the water is free from corrosive elements. A secondary heat exchanger (plate frame) between the unit and the open cooling tower may also be used.

It is imperative that all air be eliminated from the closed loop side of the heat exchanger to insure against fouling. In the heating mode, heat is absorbed from the water loop. A boiler can be utilized to maintain the loop at the desired temperature.



Water piping exposed to extreme low ambient temperatures is subject to freezing.



Consult the specification sheets for piping sizes. Teflon tape sealer should be used when connecting to the unit to insure against leaks and possible heat exchanger fouling.

Do not overtighten the connections. Flexible hoses should be used between the unit and the rigid system to avoid possible vibration. Ball valves should be installed in the supply and return lines for unit isolation and unit water flow balancing.

Pressure/temperature ports are recommended in both supply and return lines for system flow balancing. Water flow can be accurately set by measuring the water-to-refrigerant heat exchangers water side pressure drop.



See specification sheets for water flow vs. pressure drop information.

No unit should be connected to the supply or return piping until the water system has been completely cleaned and flushed to remove any dirt, piping chips or other foreign material. Supply and return hoses should be connected together during this process to ensure the entire system is properly flushed.

After the cleaning and flushing has taken place the unit may be connected to the water loop and should have all valves wide open. (Figure #15)

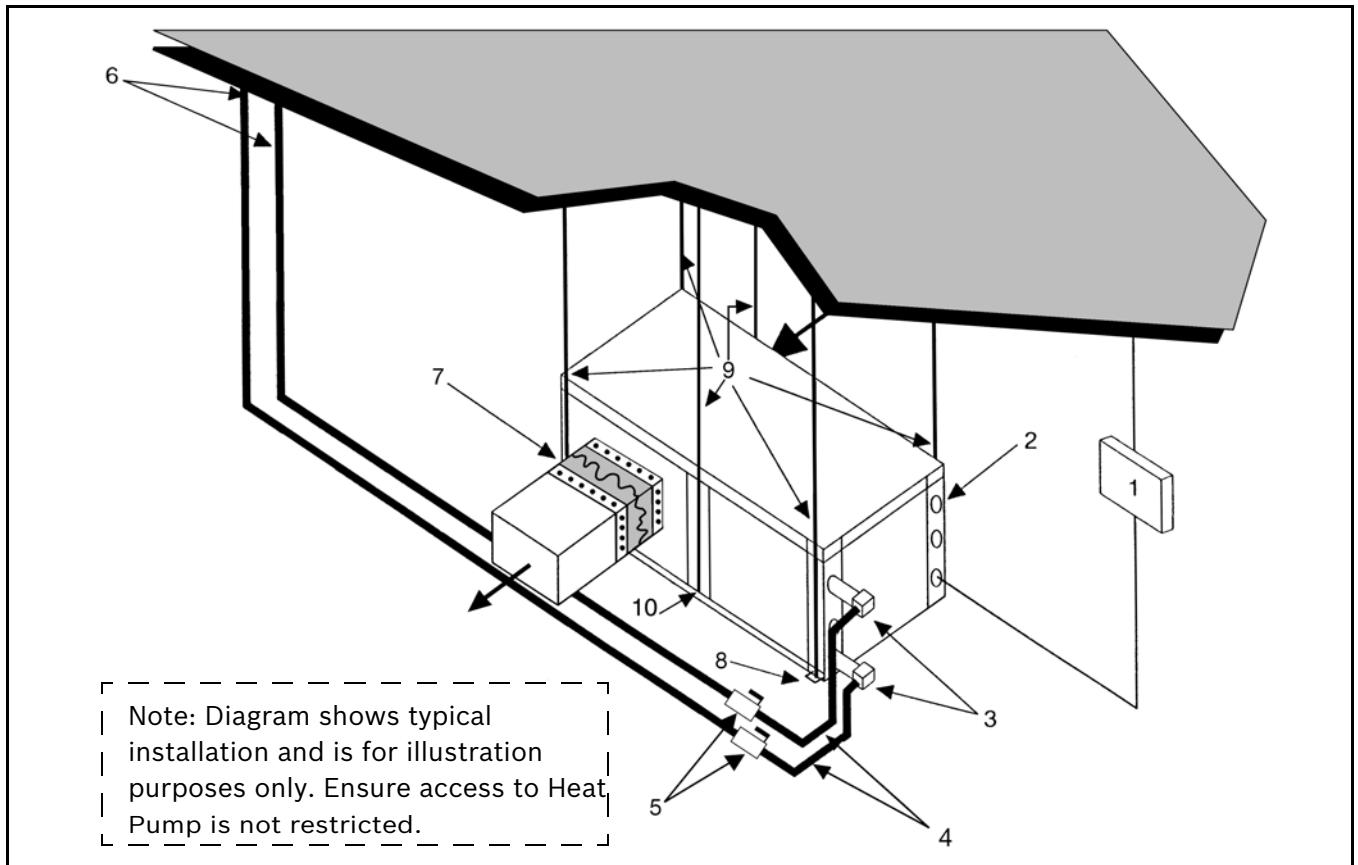

Figure # 15

- [1] Line voltage disconnect (unit)
- [2] Low voltage control connection
- [3] P/T ports (optional)
- [4] Hose kits (optional)
- [5] Ball valves
- [6] Supply and return line of central system
- [7] Flex duct connection
- [8] Hanging bracket assembly
- [9] Threaded rod
- [10] Hanging bracket assembly

Geothermal Systems

Closed loop and pond applications require specialized design knowledge. No attempt at these installations should be made unless the dealer has received specialized training. Utilizing the Ground Loop Pumping Package (GLP), makes the

installation easy. Anti-freeze solutions are utilized when low evaporating conditions are expected to occur. Refer to the GLP installation manuals for more specific instructions. (Figure #)

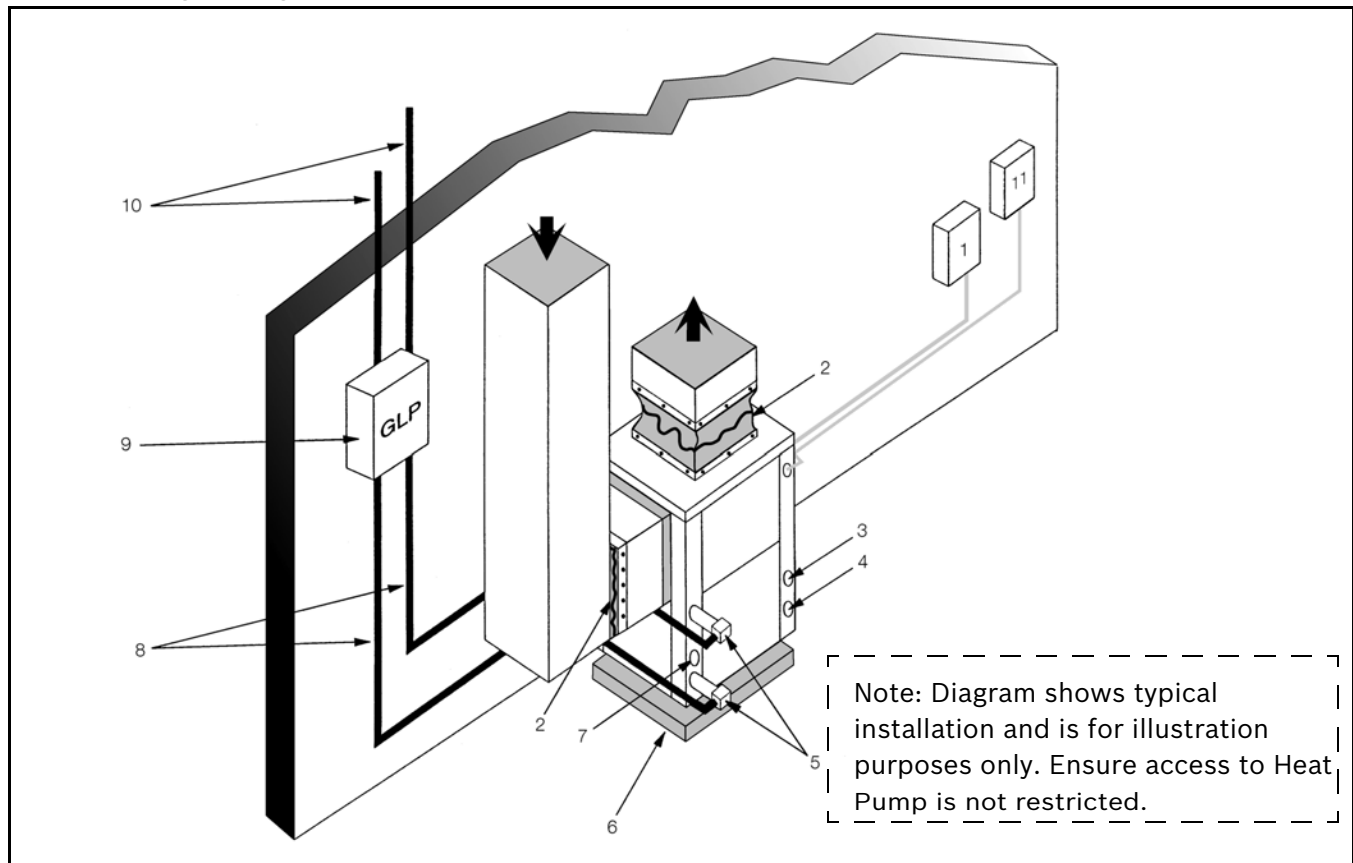

Figure # 16

- [1] Line voltage disconnect (unit)
- [2] Flex duct Connection
- [3] Low voltage control connection
- [4] Line voltage connection (unit)
- [5] P/T ports
- [6] Vibration pad
- [7] Condensate drain connection
- [8] Ground loop connection kit
- [9] Ground loop pumping package
- [10] Polyethylene with insulation
- [11] Line voltage disconnect (electric heater)

SYSTEM CHECKOUT

After completing the installation, and before energizing the unit, the following system checks should be made:

- Verify that the supply voltage to the heat pump is in accordance with the nameplate ratings.
- Make sure that all electrical connections are tight and secure.
- Check the electrical fusing and wiring for the correct size.



Ensure cabinet and Electrical Box are properly grounded.

- Verify that the low voltage wiring between the thermostat and the unit is correct.
- Verify that the water piping is complete and correct.
- Check that the water flow is correct, and adjust if necessary.
- Check the blower for free rotation, and that it is secured to the shaft.
- Verify that vibration isolation has been provided.
- Unit is serviceable. Be certain that all access panels are secured in place.

Considerations:

1. Always check incoming line voltage power supply and secondary control voltage for adequacy. Transformer primaries are dual tapped for 208 and 230 volts. Connect the appropriate tap to ensure a minimum of 18 volts secondary control voltage. 24 volts is ideal for best operation.
2. Long length thermostat and control wiring leads may create voltage drop. Increase wire gauge or up-size transformers may be required to insure minimum secondary voltage supply.
3. FHP recommends the following guidelines for wiring between a thermostat and the unit: 18 GA up to 60 foot, 16 GA up to 100 ft and 14 GA up to 140 ft.
4. Do not apply additional controlled devices to the control circuit power supply without consulting the factory. Doing so may void equipment warranties.
5. Check with all code authorities on requirements involving condensate disposal/over flow protection criteria.

UNIT START-UP

1. Put the UPM board in “test” mode.

2. Set the thermostat to the highest setting.
3. Set the thermostat system switch to “COOL”, and the fan switch to the “AUTO” position. The reversing valve solenoid should energize. The compressor and fan should not run.
4. Reduce the thermostat setting approximately 5 degrees below the room temperature.
5. Verify the heat pump is operating in the cooling mode.
6. Turn the thermostat system switch to the “OFF” position. The unit should stop running and the reversing valve should de energize.
7. Leave the unit off for approximately (5) minutes to allow for system equalization.
8. Turn the thermostat to the lowest setting.
9. Set the thermostat switch to “HEAT”.
10. Increase the thermostat setting approximately 5 degrees above the room temperature.
11. Verify the heat pump is operating in the heating mode.
12. Set the thermostat to maintain the desired space temperature.
13. Check for vibrations, leaks, etc.

MAINTENANCE

1. Filter changes or cleanings are required at regular intervals. The time period between filter changes will depend upon type of environment the equipment is used in. In a single family home, that is not under construction, changing or cleaning the filter every 60 days is sufficient. In other applications such as motels, where daily vacuuming produces a large amount of lint, filter changes may need to be as frequent as biweekly.



Equipment should never be used during construction due to likelihood of wall board dust accumulation in the air coil of the equipment which permanently affects the performance and may shorten the life of the equipment.

2. An annual “checkup” is recommended by a licensed refrigeration mechanic. Recording the performance measurements of volts, amps, and water temperature differences (both heating and cooling) is recommended. This data should be compared to the information on the unit’s data plate and the data taken at the original startup of the equipment.

3. Lubrication of the blower motor is not required, however may be performed on some motors to extend motor life. Use **SAE-20** non-detergent electric motor oil.
4. The condensate drain should be checked annually by cleaning and flushing to insure proper drainage.
5. Periodic lockouts almost always are caused by air or water flow problems. The lockout (shutdown) of the unit is a normal protective measure in the design of the equipment. If continual lockouts occur call a mechanic immediately and have them check for: water flow problems, water temperature problems, air flow problems or air temperature problems. Use of the pressure and temperature charts for the unit may be required to properly determine the cause.

Access to Internal Components for Vertical (VT) Units



See LM IOM for further reference. Manual is located inside of the unit.

1. Using a Flat screw driver remove and retain Panel Belt by inserting the screwdriver into the slot and releasing the catch. (Figures #17 and #18)



Heat pumps are supplied with panel belt which needs to be removed to access screws for panel removal. The belt is held in place by a clip on one side and an interference fit on the other end.

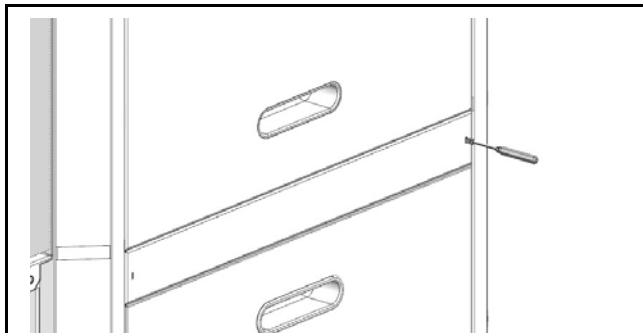

Figure # 17

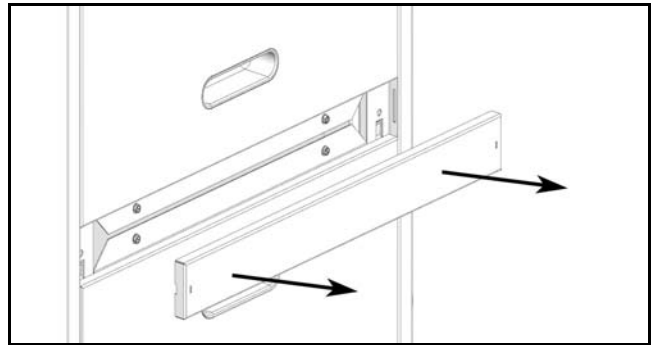

Figure # 18

2. Remove and retain lower panel by removing (3) three screws. (Figure #19)

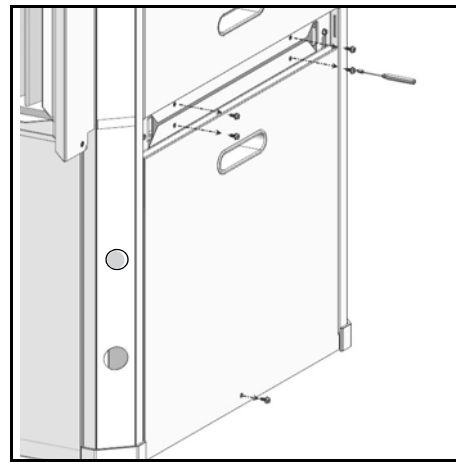

Figure # 19

3. Remove and retain upper panel by lifting up and out as shown in Figure #20.

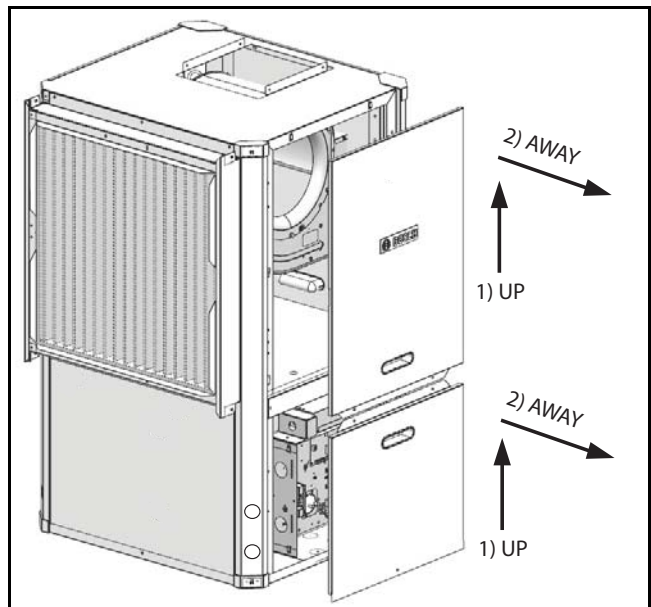

Figure # 20

4. Repeat steps 1–3 for other sides as necessary.

UNIT CHECK-OUT SHEET

Customer Data

Customer Name _____

Date _____

Address _____

Phone _____

Unit Number _____

Unit Nameplate Data

Unit Make _____

Model Number _____

Serial Number _____

Refrigerant Charge (oz) _____

Compressor: RLA _____

LRA _____

Blower Motor: FLA (or NPA) _____

HP _____

Maximum Fuse Size (Amps) _____

Maximum Circuit Ampacity _____

Operating Conditions

Cooling Mode

Heating Mode

Entering / Leaving Air Temp _____ / _____

_____ / _____

_____ / _____

Entering Air Measured at: _____

Leaving Air Measured at: _____

Entering / Leaving Fluid Temp _____ / _____

_____ / _____

_____ / _____

Fluid Flow (gpm) _____

Compressor Volts / Amps _____ / _____

_____ / _____

_____ / _____

Blower Motor Volts / Amps _____ / _____

_____ / _____

_____ / _____

Source Fluid Type _____

Fluid Flow (gpm)* _____

Fluid Side Pressure Drop* _____

Suction / Discharge Pressure (psig)* _____ / _____

_____ / _____

_____ / _____

Suction / Discharge Temp* _____ / _____

_____ / _____

_____ / _____

Suction Superheat* _____

Entering TXV / Cap Tube Temp* _____

Liquid Subcooling* _____

* Required for Troubleshooting ONLY

Auxiliary Heat

Unit Make _____

Model Number: _____

Serial Number _____

Max Fuse Size (Amps) _____

Volts / Amps _____

Entering Air Temperature _____

Leaving Air Temperature _____

Bosch Group
 601 NW 65th Court
 Fort Lauderdale, FL 33309
 Phone: (954) 776-5471
 Fax: (800) 776-5529



MAIL TO: Bosch.Fhp.TechSupport@us.bosch.com
 or scan the QR code and attach picture of this form with
 the information requested.

TROUBLESHOOTING

LM Series Water Source Heat Pump is equipped with two (2) externally mounted LEDs (Figure #21) that blink for unit errors. See Page 27 for error code descriptions.

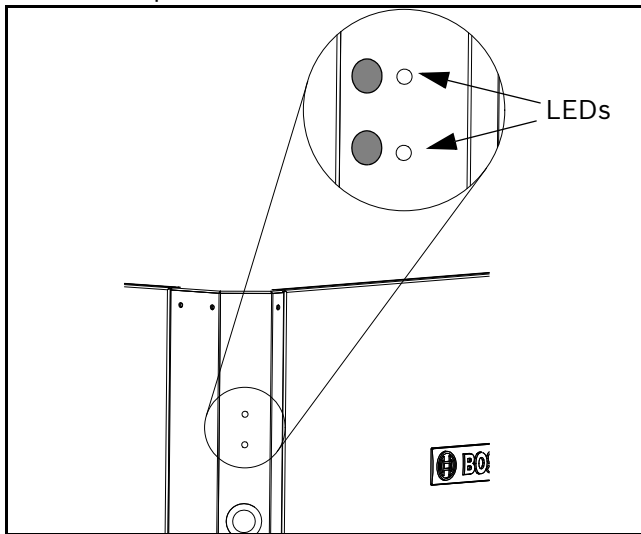

Figure # 21



Troubleshooting Information Solution column may reflect a possible fault that may be one of, or a combination of causes and solutions. Check each cause and adopt "process of elimination" and or verification of each before making any conclusion.

Unit Troubleshooting

Problem	Possible Cause	Checks and Correction
ENTIRE UNIT DOES NOT RUN	Power Supply Off	Apply power, close disconnect
	Blown Fuse	Replace fuse or reset circuit breaker. Check for correct fuses
	Voltage Supply Low	If voltage is below minimum voltage specified on unit data plate, contact local power company.
	Thermostat	Set the fan to "ON", the fan should run. Set thermostat to "COOL" and lowest temperature setting, the unit should run in the cooling mode (reversing valve energized). Set unit to "HEAT" and the highest temperature setting, the unit should run in the heating mode. If neither the blower or compressor run in all three cases, the thermostat could be miswired or faulty. To ensure miswired or faulty thermostat verify 24 volts is available on the condensing section low voltage terminal strip between "R" and "C", "Y" and "C", and "O" and "C". If the blower does not operate, verify 24 volts between terminals "G" and "C" in the air handler. Replace the thermostat if defective.
BLOWER OPERATES BUT COMPRESSOR DOES NOT	Thermostat	Check setting, calibration, and wiring
	Wiring	Check for loose or broken wires at compressor, capacitor, or contactor.
	Safety Controls	Check UPM board red default L.E.D. for Blink Code
	Compressor overload open	If the compressor is cool and the overload will not reset, replace compressor.
	Compressor motor grounded	Internal winding grounded to the compressor shell. Replace compressor. If compressor burnout, install suction filter dryer.
	Compressor windings Open	After compressor has cooled, check continuity of the compressor windings. If the windings are open, replace the compressor

Unit Troubleshooting		
Problem	Possible Cause	Checks and Correction
UNIT OFF ON HIGH PRESSURE CONTROL	Discharge pressure too high	In "COOLING" mode: Lack of or inadequate water flow. Entering water temperature is too warm. Scaled or plugged condenser. In "HEATING" mode: Lack of or inadequate air flow. Blower inoperative, clogged filter or restrictions in duct work
	Refrigerant charge	The unit is overcharged with refrigerant. Reclaim refrigerant, evacuate and recharge with factor recommended charge.
	High pressure	Check for defective or improperly calibrated high pressure switch.
UNIT OFF ON LOW PRESSURE CONTROL	Suction pressure too low	In "COOLING" mode: Lack of or inadequate air flow. Entering air temperature is too cold. Blower inoperative, clogged filter or restrictions in duct work. In "HEATING" mode: Lack of or inadequate water flow. Entering water temperature is too cold. Scaled or plugged condenser.
	Refrigerant charge	The unit is low on refrigerant. Check for refrigerant leak, repair, evacuate and recharge with factory recommended charge.
	Low pressure switch	Check for defective or improperly calibrated low pressure switch.
UNIT SHORT CYCLES	Unit oversized	Recalculate heating and or cooling loads.
	Thermostat	Thermostat installed near a supply air grill; relocate thermostat. Readjust heat anticipator.
	Wiring and controls	Check for defective or improperly calibrated low pressure switch.
INSUFFICIENT COOLING OR HEATING	Unit undersized	Recalculate heating and or cooling loads. If excessive, possibly adding insulation and shading will rectify the problem
	Loss of conditioned air by leakage	Check for leaks in duct work or introduction of ambient air through doors or windows
	Airflow	Lack of adequate air flow or improper distribution of air. Replace dirty filter
	Refrigerant charge	Low on refrigerant charge causing inefficient operation
	Compressor	Check for defective compressor. If discharge is too low and suction pressure is too high, compressor is not pumping properly. Replace compressor.
	Reversing Valve	Defective reversing valve creating bypass of refrigerant from discharge of suction side of compressor. Replace reversing valve
	Operating pressures	Compare unit operation pressures to the pressure/temperature chart for the unit.
	TXV	Check TXV for possible restriction or defect. Replace if necessary.
Moisture, noncondensables	The refrigerant system may be contaminated with moisture or noncondensables. Reclaim refrigerant, replace filter dryer, evacuate the refrigerant system, and recharge with factory recommended charge.	

Compressor Ohms				
Model	Voltage	Start Winding	Line-to-Line	Run Winding
LM024	-1	1.64		1.30
	-2	2.17		1.48
	-3	2.153	2.153	1.763
	-4	8.60	8.60	7.30
LM036	-1	1.52		0.88
	-2	1.15		1.22
	-3	1.53	1.53	1.21
	-4	5.87	5.87	4.86
LM048	-1	1.86		0.52
	-2	0.88		0.70
	-3	1.03	1.03	0
	-4	4.17	4.17	0
LM060	-1	1.63		0.39
	-2	0.87		0.52
	-3	0.68	0.68	0
	-4	3.20	3.2	0
LM070	-1	1.85		0.34
	-3	0.60	0.60	0
	-4	2.52	2.52	0
Tolerance +/- 7%. All resistance values must be measured with compressor at room temperature.				

UPM Board LED Indications

Indication Color	Blinks	Description
GREEN	Solid	18-30 VAC Power is present
RED	1	High pressure lockout
RED	2	Low pressure lockout
RED	3	Freeze sensor lockout
RED	4	Condensate overflow
RED	5	Brownout
RED	6	Evaporator Freeze condition

Comfort Alert Module -Flash Codes

Status LED	Status LED Description	Status LED Troubleshooting Information Solution
YELLOW "ALERT" FLASH CODE 3	Short Cycling Compressor is running only briefly	<ol style="list-style-type: none"> 1. Thermostat demand signal is intermittent 2. Time delay relay or control board defective 3. If high pressure switch present go to Flash Code 2 information 4. If low pressure switch present go to Flash Code 1 information
YELLOW "ALERT" FLASH CODE 4	Locked Rotor	<ol style="list-style-type: none"> 1. Run capacitor has failed (may not be bad, verify) 2. Low line voltage (contact utility if voltage at disconnect is low) <ul style="list-style-type: none"> • Check wiring connections 3. Excessive liquid refrigerant in compressor 4. Compressor bearings are seized <ul style="list-style-type: none"> • Measure compressor oil level

Comfort Alert Module -Flash Codes

Status LED	Status LED Description	Status LED Troubleshooting Information Solution
YELLOW "ALERT" FLASH CODE 5	Open Circuit	<ol style="list-style-type: none"> 1. Outdoor unit power disconnect is open 2. Compressor circuit breaker or fuse(s) is open 3. Compressor contactor has failed open <ul style="list-style-type: none"> • Check compressor contactor wiring and connectors • Check for compressor contactor failure (burned, pitted or open) • Check wiring and connectors between supply and compressor • Check for low pilot voltage at compressor contactor coil 4. High pressure switch is open and requires manual reset 5. Open circuit in compressor supply wiring or connections 6. Unusually long compressor protector reset time due to extreme ambient temperature 7. Compressor windings are damaged <ul style="list-style-type: none"> • Check compressor motor winding resistance
YELLOW "ALERT" FLASH CODE 6	Open Start Circuit Current only in run circuit	<ol style="list-style-type: none"> 1. Run capacitor has failed (may not be bad, verify) 2. Open circuit in compressor start wiring or connections <ul style="list-style-type: none"> • Check wiring and connectors between supply and the compressor "S" terminal 3. Compressor start winding is damaged <ul style="list-style-type: none"> • Check compressor motor winding resistance
YELLOW "ALERT" FLASH CODE 7	Open Run Circuit Current only in start circuit	<ol style="list-style-type: none"> 1. Open circuit in compressor run wiring or connections <ul style="list-style-type: none"> • Check wiring and connectors between supply and the compressor "R" terminal 2. Compressor run winding is damaged <ul style="list-style-type: none"> • Check compressor motor winding resistance
YELLOW "ALERT" FLASH CODE 8	Welded Contactor Compressor always runs	<ol style="list-style-type: none"> 1. Compressor contactor has failed closed 2. Thermostat demand signal not connected to module
YELLOW "ALERT" FLASH CODE 9	Low Voltage Control circuit < 17VAC	<ol style="list-style-type: none"> 1. Control circuit transformer is overloaded 2. Low line voltage (contact utility if voltage at disconnect is low) <ul style="list-style-type: none"> • Check wiring connections Flash Code number corresponds to a number of LED flashes, followed by a pause and then repeated. TRIP and ALERT LEDs flashing at same time means control circuit voltage is too low for operation

ELECTRONIC THERMOSTAT INSTALLATION

Position the thermostat subbase against the wall so that it is level and the thermostat wires protrude through the middle of the subbase. Mark the position of the subbase mounting holes and drill holes with a 3/16-inch bit. Install supplied anchors and secure base to the wall. Thermostat wire must be 8-conductor, 18-AWG wire. Strip the wires back 1/4-inch (longer strip lengths may cause shorts) and insert the thermostat wires into the connector as shown. Tighten the screws to ensure secure connections. The thermostat has the same type connectors, requiring the same wiring. See instructions in the thermostat for detailed installation and operation information.



When using a 2-cool, 3-heat thermostat both the W1 & W2 on the Heat Pump and W2 & EM on the thermostat must be connected together via a jumper. (See Figure#22)



Packaged heat pumps are equipped with detachable Thermostat connectors. These connectors are located in different locations based on the blower motor that is installed in the unit.

a) For the X13 motor, the two detachable connectors are on the Main Harness; connectors are marked as P1 and P2. See Wire Harness Drawing on Pg#53.

b) For the EON motor, the three detachable thermostat connectors are located on the ECM Interface board. See Wiring Harness Drawing on Pg#54.



Harness wiring can be loose, based on the options installed for the unit. See the Wiring Harness Drawing notes for further details.

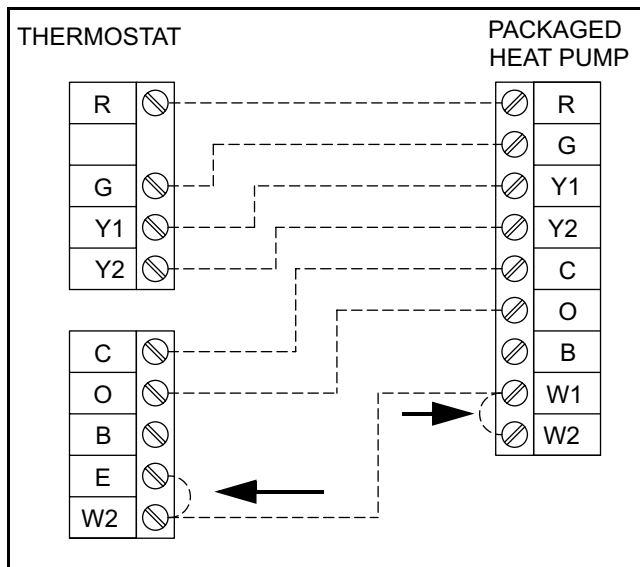

Figure # 22

OPERATING TEMPERATURES AND PRESSURES

Operating Temperatures and Pressures										
			COOLING				HEATING			
Model	Entering Water Temp. F	Water Flow	Suction Pressure PSIG	Discharge Pressure PSIG	Water Temp Rise °F	Air Temp Drop °F	Suction Pressure PSIG	Discharge Pressure PSIG	Water Temp Drop	Air Temp Rise °F
LM024 Part Load	30°	4					75-91	264-322	5-6	15-17
		8					79-96	270-331	3-4	16-18
	40°	4					88-107	277-339	6-7	17-20
		8	115-140	175-214	8-9	19-23	92-112	284-348	4-5	18-21
	50°	4	129-157	218-267	14-17	18-20	98-122	291-356	7-8	20-23
		8	124-151	204-250	8-9	19-22	110-130	298-364	5-6	21-24
	60°	4	134-163	249-305	13-16	17-20	112-136	304-372	8-10	22-26
		8	128-156	233-287	8-9	18-21	117-143	312-381	6-7	23-28
	70°	4	138-168	281-341	13-16	17-19	124-152	318-389	9-11	24-29
		8	133-161	263-323	7-9	18-21	131-159	325-398	6-8	26-31
	80°	4	143-174	317-388	13-16	16-19	136-166	331-405	11-13	27-32
		8	137-167	297-366	7-9	17-20	143-174	339-415	7-9	28-33
	90°	4	147-179	357-437	13-16	16-18	149-181	345-422	12-14	29-35
		8	141-172	335-411	7-9	17-20	156-190	352-432	8-10	31-37
100°	4	151-185	402-492	13-15	15-18					
	8	146-177	378-459	7-9	16-19					
LM024 Full Load	30°	4					76-92	242-297	3-4	13-14
		8					80-97	249-304	2-3	13-15
	40°	4	125-151	180-221	14-18	19-22	89-108	255-312	4-5	15-17
		8	120-146	169-207	8-10	20-23	93-113	261-320	3-3	16-18
	50°	4	134-163	211-258	14-18	18-21	106-118	267-327	5-6	17-19
		8	129-157	198-242	8-10	19-23	110-126	274-335	3-4	18-21
	60°	4	139-169	241-295	14-17	18-21	113-138	280-342	6-7	19-22
		8	134-163	227-278	8-10	19-22	119-145	287-351	4-5	20-23
	70°	4	144-175	272-333	14-17	17-20	126-155	292-358	7-8	21-24
		8	138-168	255-313	8-10	18-21	133-162	300-367	5-6	22-26
	80°	4	148-181	307-375	14-17	17-19	138-168	305-373	8-9	23-27
		8	143-174	288-353	8-10	18-21	145-177	312-382	5-6	24-29
	90°	4	153-186	346-423	14-17	16-19	151-184	317-388	8-10	25-29
		8	147-179	325-398	8-9	17-20	158-193	325-398	6-7	26-31
100°	4	158-191	389-477	13-16	16-18					
	8	152-185	366-448	8-9	17-20					

This chart shows approximate temperatures and pressures for a unit in good repair. The values shown are meant as a guide only and should not be used to estimate system charge. This chart assumes rated air flow and 80° d.b./67° w.b. entering air temperature in cooling, 70° d.b. entering air temperature in heating. Heating data at entering fluid temperatures below 50° assumes the use of antifreeze. As a result of continuing research and development, specifications are subject to change without notice.

Operating Temperatures and Pressures										
			COOLING				HEATING			
LM036 Part Load	30°	4.5					73-89	266-325	5-6	15-18
		9.0					77-94	272-333	3-4	16-19
	40°	4.5	117-143	189-231	14-17	18-22	86-105	279-341	6-7	17-21
		9.0	112-137	178-217	8-9	19-24	90-110	286-350	4-5	18-22
	50°	4.5	126-154	221-270	14-17	18-21	105-125	293-358	7-8	20-24
		9.0	121-148	207-253	8-9	19-23	109-130	300-366	5-6	21-25
	60°	4.5	131-160	252-308	13-16	17-21	110-134	306-374	8-10	22-27
		9.0	125-153	237-290	8-9	18-22	115-141	314-383	6-7	23-29
	70°	4.5	135-165	284-347	13-16	17-20	122-150	320-391	9-11	24-30
		9.0	130-158	266-326	7-9	18-22	129-157	327-400	6-8	26-32
	80°	4.5	140-171	320-391	13-16	16-20	134-164	333-407	11-13	27-33
		9.0	134-164	300-367	7-9	17-21	141-172	341-417	7-9	28-35
	90°	4.5	144-176	360-440	13-16	16-19	147-179	347-424	12-14	29-36
		9.0	138-169	338-414	7-9	17-21	154-188	355-434	8-10	31-38
100°	4.5	149-182	405-495	13-15	15-19					
	9.0	143-174	381-465	7-9	16-20					
LM036 Full Load	30°	4.5					74-90	244-299	3-4	13-15
		9.0					78-95	251-306	2-3	13-16
	40°	4.5	122-149	183-224	14-18	19-23	87-106	257-314	4-5	15-18
		9.0	117-143	172-210	8-10	20-24	91-111	263-322	3-3	16-19
	50°	4.5	131-160	214-261	14-18	18-22	95-105	269-329	5-6	17-20
		9.0	126-154	201-245	8-10	19-24	100-125	276-337	3-4	18-22
	60°	4.5	136-166	244-298	14-17	18-22	111-136	282-344	6-7	19-23
		9.0	131-160	230-281	8-10	19-23	117-143	289-353	4-5	20-24
	70°	4.5	141-172	275-336	14-17	17-21	124-152	294-360	7-8	21-25
		9.0	135-165	258-316	8-10	18-22	131-160	302-369	5-6	22-27
	80°	4.5	145-178	310-378	14-17	17-20	136-166	307-375	8-9	23-28
		9.0	140-171	291-356	8-10	18-22	143-175	314-384	5-6	24-30
	90°	4.5	150-183	349-426	14-17	16-20	149-182	319-390	8-10	25-30
		9.0	144-176	328-401	8-9	17-21	156-191	327-400	6-7	26-32
100°	4.5	155-189	392-480	13-16	16-19					
	9.0	149-182	369-451	8-9	17-21					

This chart shows approximate temperatures and pressures for a unit in good repair. The values shown are meant as a guide only and should not be used to estimate system charge. This chart assumes rated air flow and 80° d.b./67° w.b. entering air temperature in cooling, 70° d.b. entering air temperature in heating. Heating data at entering fluid temperatures below 50° assumes the use of antifreeze. As a result of continuing research and development, specifications are subject to change without notice.

Operating Temperatures and Pressures										
			COOLING				HEATING			
LM048 Part Load	30°	6.0					64-78	248-303	5-6	15-18
		12.0					67-82	254-311	3-4	16-19
	40°	6.0	109-134	183-224	18-22	19-23	75-91	261-319	6-8	17-21
		12.0	105-128	172-210	10-12	20-25	79-96	267-327	4-5	18-23
	50°	6.0	118-144	214-261	18-22	19-23	78-90	273-334	8-10	20-24
		12.0	113-138	201-245	10-12	20-24	82-95	280-342	5-7	21-26
	60°	6.0	122-149	244-298	17-21	18-22	96-117	286-349	9-11	22-27
		12.0	117-143	230-281	10-12	19-24	101-123	293-358	6-8	24-29
	70°	6.0	126-154	275-336	17-21	18-22	107-131	299-365	11-13	25-30
		12.0	121-148	258-316	10-12	19-23	113-138	306-374	7-9	26-32
	80°	6.0	130-159	310-378	17-21	17-21	117-143	311-380	12-15	27-33
		12.0	132-153	291-356	10-12	18-22	123-151	319-390	8-10	29-35
	90°	6.0	134-164	349-426	17-20	17-20	128-157	324-396	13-16	29-36
		12.0	129-158	328-401	9-12	18-22	135-165	332-406	9-11	31-38
100°	6.0	139-170	392-480	16-20	16-20					
	12.0	133-163	369-451	9-11	17-21					
LM048 Full Load	30°	6.0					71-87	277-339	6-7	15-19
		12.0					75-92	284-347	4-5	16-20
	40°	6.0	118-144	194-237	21-25	19-23	84-102	291-356	7-9	18-22
		12.0	113-138	182-223	12-14	20-24	88-108	299-365	5-6	19-23
	50°	6.0	127-155	226-276	21-25	18-22	92-110	305-373	9-11	20-25
		12.0	122-149	213-260	12-14	19-24	98-120	313-383	6-7	21-26
	60°	6.0	131-160	259-316	21-25	18-22	108-132	320-391	10-13	23-28
		12.0	126-154	243-297	12-14	19-23	113-138	328-400	7-9	24-29
	70°	6.0	136-166	291-355	20-25	17-21	120-147	334-408	12-15	25-31
		12.0	130-159	273-334	12-14	18-22	126-154	342-418	8-10	27-32
	80°	6.0	140-171	328-401	20-24	17-20	131-161	348-425	14-17	27-34
		12.0	135-165	308-377	11-14	18-22	138-169	356-436	9-11	29-36
	90°	6.0	145-177	369-451	20-24	16-20	144-176	362-442	15-18	30-37
		12.0	139-170	347-424	11-14	17-21	151-185	371-453	10-12	32-39
100°	6.0	149-183	415-508	19-24	16-19					
	12.0	143-175	391-477	11-14	17-21					

This chart shows approximate temperatures and pressures for a unit in good repair. The values shown are meant as a guide only and should not be used to estimate system charge. This chart assumes rated air flow and 80° d.b./67° w.b. entering air temperature in cooling, 70° d.b. entering air temperature in heating. Heating data at entering fluid temperatures below 50° assumes the use of antifreeze. As a result of continuing research and development, specifications are subject to change without notice.

Operating Temperatures and Pressures										
			COOLING				HEATING			
LM060 Part Load	30°	7.0					68-84	256-313	5-7	19-23
		14.0					73-89	261-319	4-5	20-25
	40°	7.0	113-138	172-210	18-22	19-23	81-99	277-339	7-8	22-26
		14.0	110-134	161-196	12-14	20-24	86-105	283-346	5-6	23-28
	50°	7.0	116-142	206-252	17-21	19-23	93-114	299-365	8-9	24-29
		14.0	112-137	193-236	12-14	19-24	99-121	305-373	6-7	25-31
	60°	7.0	118-145	241-294	17-21	18-23	106-129	321-392	9-11	26-32
		14.0	115-140	225-275	11-14	19-23	113-138	327-400	7-8	28-34
	70°	7.0	121-148	275-336	17-21	18-22	118-145	342-418	10-12	29-35
		14.0	117-143	257-314	11-14	19-23	126-154	349-427	8-9	30-37
	80°	7.0	123-151	309-378	16-20	18-22	131-160	364-444	11-14	31-38
		14.0	120-146	289-353	11-13	19-23	139-170	371-454	8-10	33-40
	90°	7.0	126-154	344-420	16-20	18-22	143-175	385-471	12-15	33-41
		14.0	122-149	321-392	11-13	18-22	152-186	393-480	9-11	35-43
100°	7.0	128-157	378-462	16-19	17-21					
	14.0	125-152	353-432	11-13	18-22					
LM060 Full Load	30°	7.0					68-84	256-313	5-7	19-23
		14.0					73-89	261-319	4-5	20-25
	40°	7.0	117-143	182-222	15-19	21-26	81-99	277-339	7-8	22-26
		14.0	114-139	170-208	11-14	22-27	86-105	283-346	5-6	23-28
	50°	7.0	120-147	215-263	15-18	20-25	93-114	299-365	8-9	24-29
		14.0	117-143	201-246	11-14	21-26	99-121	305-373	6-7	25-31
	60°	7.0	123-150	248-304	14-17	20-24	106-129	321-392	9-11	26-32
		14.0	119-146	232-284	11-13	21-25	113-138	327-400	7-8	28-34
	70°	7.0	126-154	282-344	14-17	19-24	118-145	342-418	10-12	29-35
		14.0	122-149	263-322	10-13	20-25	126-154	349-427	8-9	30-37
	80°	7.0	129-157	315-385	13-16	19-23	131-160	364-444	11-14	31-38
		14.0	125-153	294-360	10-12	19-24	139-170	371-454	8-10	33-40
	90°	7.0	132-161	348-426	13-16	18-22	143-175	385-471	12-15	33-41
		14.0	128-156	326-398	10-12	19-23	152-186	393-480	9-11	35-43
100°	7.0	134-164	382-466	12-15	17-21					
	14.0	131-160	357-436	9-11	18-22					

This chart shows approximate temperatures and pressures for a unit in good repair. The values shown are meant as a guide only and should not be used to estimate system charge. This chart assumes rated air flow and 80° d.b./67° w.b. entering air temperature in cooling, 70° d.b. entering air temperature in heating. Heating data at entering fluid temperatures below 50° assumes the use of antifreeze. As a result of continuing research and development, specifications are subject to change without notice.

Operating Temperatures and Pressures										
		COOLING				HEATING				
LM070 Part Load	30°	9.0					71-87	259-316	5-7	19-23
		18.0					76-92	264-322	4-5	20-25
	40°	9.0	116-141	175-213	18-22	19-23	84-102	280-342	7-8	22-26
		18.0	113-137	164-199	12-14	20-24	89-108	286-349	5-6	23-28
	50°	9.0	119-145	209-255	17-21	19-23	96-117	302-368	8-9	24-29
		18.0	115-140	196-239	12-14	19-24	102-124	308-376	6-7	25-31
	60°	9.0	121-148	244-297	17-21	18-23	109-132	324-395	9-11	26-32
		18.0	118-143	228-278	11-14	19-23	116-141	330-403	7-8	28-34
	70°	9.0	124-151	278-339	17-21	18-22	121-148	345-421	10-12	29-35
		18.0	120-146	260-317	11-14	19-23	129-157	352-430	8-9	30-37
	80°	9.0	126-154	312-381	16-20	18-22	134-163	367-447	11-14	31-38
		18.0	123-149	292-356	11-13	19-23	142-173	374-457	8-10	33-40
	90°	9.0	129-157	347-423	16-20	18-22	146-178	388-474	12-15	33-41
		18.0	125-152	324-395	11-13	18-22	155-189	396-483	9-11	35-43
100°	9.0	131-160	381-465	16-19	17-21					
	18.0	128-155	356-435	11-13	18-22					
LM070 Full Load	30°	9.0					71-87	259-316	5-7	19-23
		18.0					76-92	264-322	4-5	20-25
	40°	9.0	120-146	185-225	15-19	21-26	84-102	280-342	7-8	22-26
		18.0	117-142	173-211	11-14	22-27	89-108	286-349	5-6	23-28
	50°	9.0	123-150	218-266	15-18	20-25	96-117	302-368	8-9	24-29
		18.0	120-146	204-249	11-14	21-26	102-124	308-376	6-7	25-31
	60°	9.0	126-153	251-307	14-17	20-24	109-132	324-395	9-11	26-32
		18.0	122-149	235-287	11-13	21-25	116-141	330-403	7-8	28-34
	70°	9.0	129-157	285-347	14-17	19-24	121-148	345-421	10-12	29-35
		18.0	125-152	266-325	10-13	20-25	129-157	352-430	8-9	30-37
	80°	9.0	132-160	318-388	13-16	19-23	134-163	367-447	11-14	31-38
		18.0	128-156	297-363	10-12	19-24	142-173	374-457	8-10	33-40
	90°	9.0	135-164	351-429	13-16	18-22	146-178	388-474	12-15	33-41
		18.0	131-159	329-401	10-12	19-23	155-189	396-483	9-11	35-43
100°	9.0	137-167	385-469	12-15	17-21					
	18.0	134-163	360-439	9-11	18-22					

This chart shows approximate temperatures and pressures for a unit in good repair. The values shown are meant as a guide only and should not be used to estimate system charge. This chart assumes rated air flow and 80° d.b./67° w.b. entering air temperature in cooling, 70° d.b. entering air temperature in heating. Heating data at entering fluid temperatures below 50° assumes the use of antifreeze. As a result of continuing research and development, specifications are subject to change without notice.

AIRFLOW TABLES

Constant Torque Motor Airflow Table (LM0**-***-***-1*)

ECM Const Torque Motor - X13															
Models	Fan Speed	Rated Airflow	Factory setting	External Static Pressure (in of Water)											
				0.10	0.20	0.30	0.40	0.50	0.60	0.70	0.80	0.90	1.00	1.10	1.20
LM024	5	950		1154	1117	1077	1034	988	938	886	830	-	-	-	-
	4	825	FL	1072	1018	966	915	866	818	772	727	-	-	-	-
	3	725		976	920	867	815	766	719	674	631	-	-	-	-
	2	650	PL/Fan only	906	844	785	730	678	630	585	544	-	-	-	-
	1	500		829	750	676	610	551	498	451	412	-	-	-	-
LM036	5	1300		1506	1469	1430	1390	1347	1300	1249	1193	1130	1061	-	-
	4	1100	FL	1425	1326	1250	1191	1143	1100	1056	1006	942	860	-	-
	3	950		1354	1233	1138	1063	1002	950	901	850	791	719	-	-
	2	800	PL/Fan only	1294	1157	1041	946	866	800	744	696	653	611	-	-
	1	750		1213	1084	976	886	812	750	698	653	612	573		
LM048	5	1800		1950	1912	1880	1852	1826	1800	1771	1737	1695	1644	-	-
	4	1600	FL	1774	1738	1703	1669	1635	1600	1562	1521	1475	1423	-	-
	3	1400		1565	1526	1493	1463	1432	1400	1363	1319	1265	1199	-	-
	2	1300	PL/Fan only	1506	1469	1430	1390	1347	1300	1249	1193	1130	1061	-	-
	1	1100		1425	1326	1250	1191	1143	1100	1056	1006	942	860	-	-
LM060	5	2200		2476	2403	2338	2283	2237	2200	2172	2153	2142	2141	2149	2166
	4	2000	FL	2170	2135	2100	2066	2033	2000	1968	1937	1907	1877	1848	1819
	3	1800		1942	1914	1886	1858	1829	1800	1770	1741	1710	1680	1649	1617
	2	1600	PL/Fan only	1766	1729	1693	1660	1629	1600	1573	1548	1526	1505	1487	1470
	1	1400		1561	1520	1483	1451	1423	1400	1381	1366	1356	1350	1349	1352
LM070	5	2500		2723	2671	2622	2578	2537	2500	2467	2437	2412	2390	2372	2358
	4	2350	FL	2566	2529	2489	2446	2399	2350	2298	2242	2184	2122	2057	1990
	3	2100		2256	2230	2202	2171	2137	2100	2060	2017	1971	1922	1871	1816
	2	1850	PL/Fan only	2004	1975	1945	1915	1883	1850	1816	1781	1745	1708	1669	1630
	1	1600		1766	1728	1693	1660	1629	1600	1573	1548	1526	1505	1486	1470

FL Full Load
PL Part Load

Constant Airflow Motor Airflow Table (LM0**-***-***-A*)

ECM Const CFM Motor - EON														
Models	Fan Speed	Rated Airflow	Adjust	Tap	External Static Pressure (in of Water)									
					0.10	0.20	0.30	0.40	0.50	0.60	0.70	0.80	0.90	1.00
LM024 Part Load	Hi	725	+	A	725	725	725	725	725	725	725	725	-	-
	Med	650	Normal	A	650	650	650	650	650	650	650	650	-	-
	Low	500	-	A	500	500	500	500	500	500	500	500	-	-
LM024 Full Load	Hi	950	+	A	950	950	950	950	950	950	950	950	-	-
	Med	825	Normal	A	825	825	825	825	825	825	825	825	-	-
	Low	725	-	A	725	725	725	725	725	725	725	725	-	-
LM036 Part Load	Hi	950	+	A	950	950	950	950	950	950	950	950	950	950
	Med	800	Normal	A	800	800	800	800	800	800	800	800	800	800
	Low	750	-	A	750	750	750	750	750	750	750	750	750	750
LM036 Full Load	Hi	1300	+	A	1300	1300	1300	1300	1300	1300	1300	1300	1300	1300
	Med	1100	Normal	A	1100	1100	1100	1100	1100	1100	1100	1100	1100	1100
	Low	950	-	A	950	950	950	950	950	950	950	950	950	950
LM048 Part Load	Hi	1400	+	A	1400	1400	1400	1400	1400	1400	1400	1400	1400	1400
	Med	1300	Normal	A	1300	1300	1300	1300	1300	1300	1300	1300	1300	1300
	Low	1100	-	A	1100	1100	1100	1100	1100	1100	1100	1100	1100	1100
LM048 Full Load	Hi	1800	+	A	1800	1800	1800	1800	1800	1800	1800	1800	1800	1800
	Med	1600	Normal	A	1600	1600	1600	1600	1600	1600	1600	1600	1600	1600
	Low	1400	-	A	1400	1400	1400	1400	1400	1400	1400	1400	1400	1400
LM060 Part Load	Hi	1800	+	A	1800	1800	1800	1800	1800	1800	1800	1800	1800	1800
	Med	1600	Normal	A	1600	1600	1600	1600	1600	1600	1600	1600	1600	1600
	Low	1400	-	A	1400	1400	1400	1400	1400	1400	1400	1400	1400	1400
LM060 Full Load	Hi	2200	+	A	2200	2200	2200	2200	2200	2200	2200	2200	2200	2200
	Med	2000	Normal	A	2000	2000	2000	2000	2000	2000	2000	2000	2000	2000
	Low	1800	-	A	1800	1800	1800	1800	1800	1800	1800	1800	1800	1800
LM070 Part Load	Hi	2100	+	A	2100	2100	2100	2100	2100	2100	2100	2100	2100	2100
	Med	1850	Normal	A	1850	1850	1850	1850	1850	1850	1850	1850	1850	1850
	Low	1600	-	A	1600	1600	1600	1600	1600	1600	1600	1600	1600	1600
LM070 Full Load	Hi	2500	+	A	2500	2500	2500	2500	2500	2500	2500	2500	2500	2500
	Med	2350	Normal	A	2350	2350	2350	2350	2350	2350	2350	2350	2350	2350
	Low	2100	-	A	2100	2100	2100	2100	2100	2100	2100	2100	2100	2100

Figure # 23

Figure 24: Water side pressure drop in PSIG

Series	GPM	Water PD @ 77°EWT with Water
LM024	3	0.7
	4	1.2
	5	1.7
	6	2.4
	7	3.2
	8	4.0
LM036	4.5	1.3
	6	2.2
	7.5	3.2
	9	4.5
	10.5	5.9
	12	7.5
LM048	6	1.1
	8	1.8
	10	2.7
	12	3.7
	14	4.9
	16	6.2
LM060	7.5	1.1
	10	1.9
	12.5	2.8
	15	3.9
	17.5	5.2
	20	6.6
LM070	9	0.9
	12	1.4
	15	2.1
	18	3.0
	21	3.9
	24	5.0

WIRING DIAGRAMS

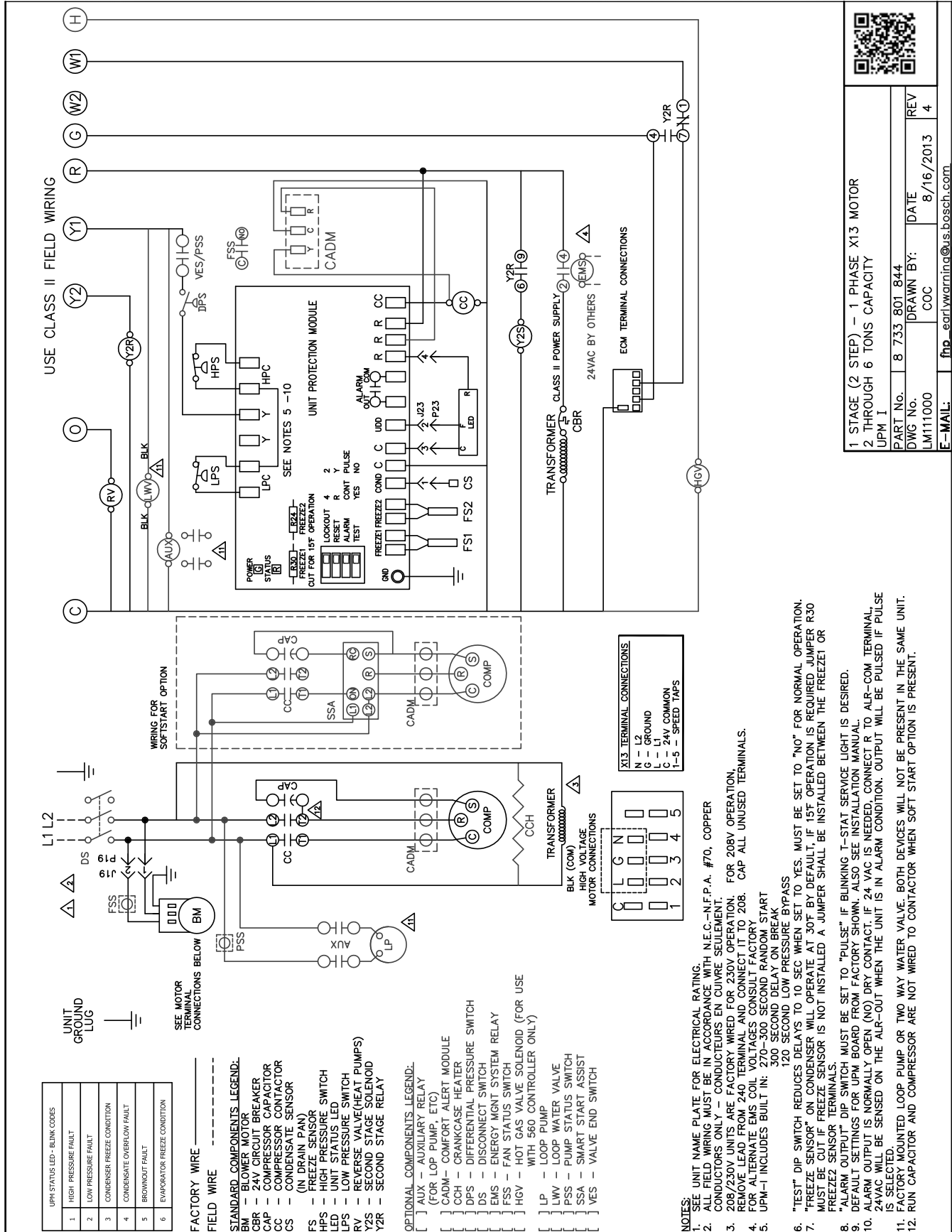



Figure # 25



1 STAGE (2 STEP) - 1 PHASE X13 MOTOR
2 THROUGH 6 TONS CAPACITY
UPM 1

PART No.	8 733 801 844	DRAWN BY:	DATE
DWG No.	LM111000	COC	8/16/2013
E-MAIL:	fnp_earlywarning@us.bosch.com		

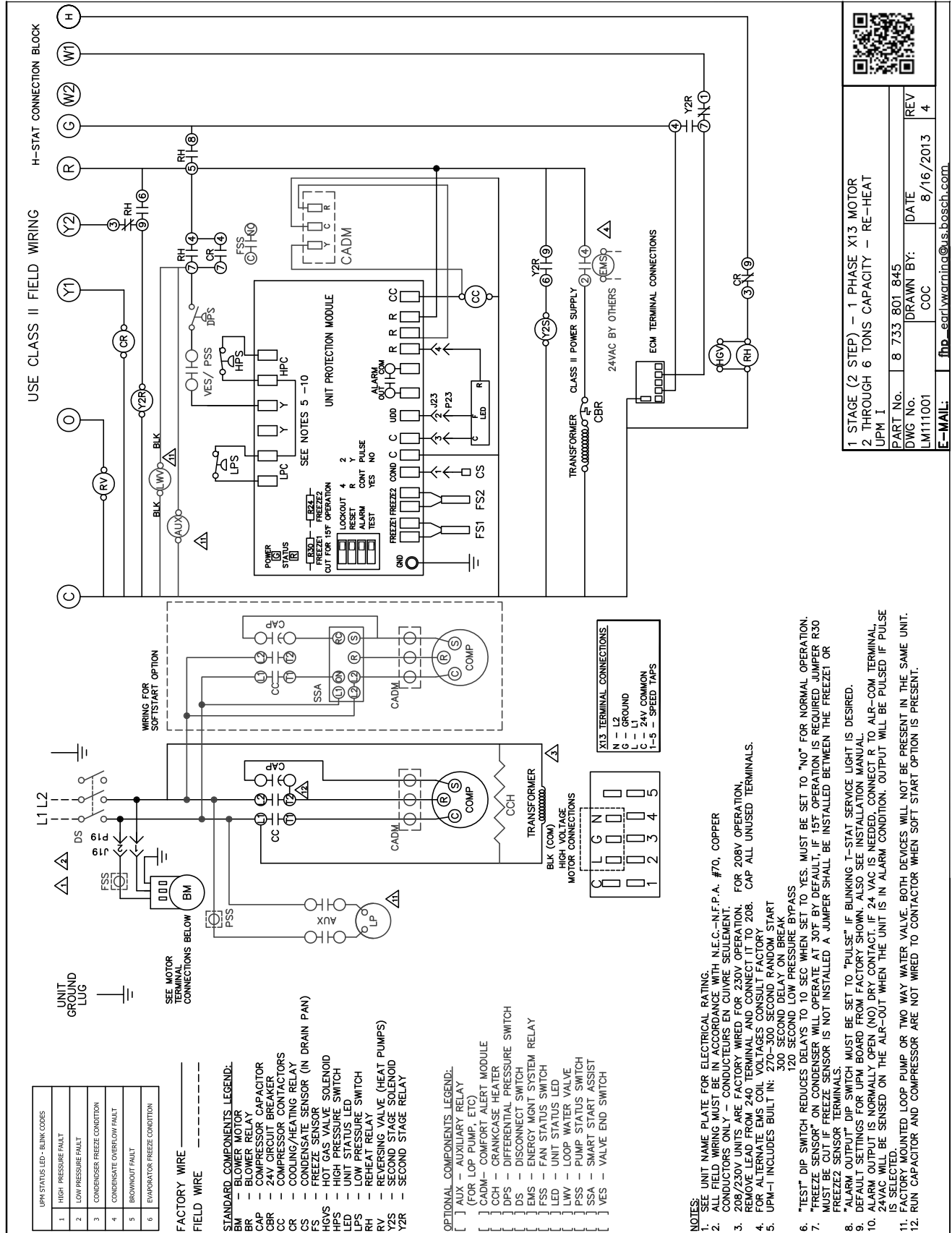

Figure # 26

1 STAGE (2 STEP) - 1 PHASE X13 MOTOR
2 THROUGH 6 TONS CAPACITY - RE-HEAT UPM I

PART No.	8 733 801 845	DATE	8/16/2013
DWG No.	LM111001	COC	4
REV			

E-MAIL: ftp_earlywiring@us.bosch.com

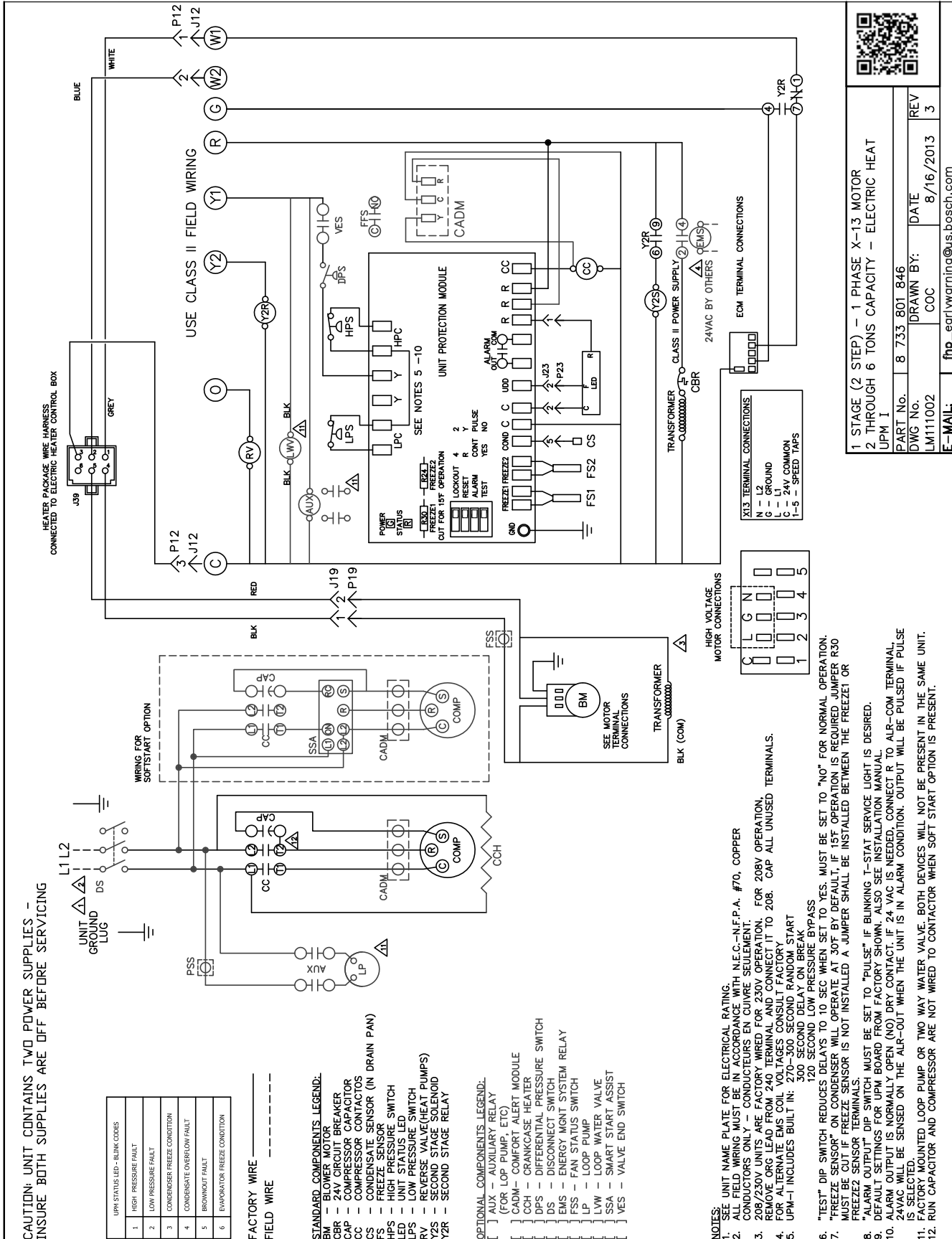

Figure # 27

1 STAGE (2 STEP) - 1 PHASE X-13 MOTOR
2 THROUGH 6 TONS CAPACITY - ELECTRIC HEAT UPM I

PART No. 8 733 801 846
 DWG No. LM111002
 DRAWN BY: COC
 DATE: 8/16/2013
 REV: 3

E-MAIL: fhp_earlywiring@us.bosch.com

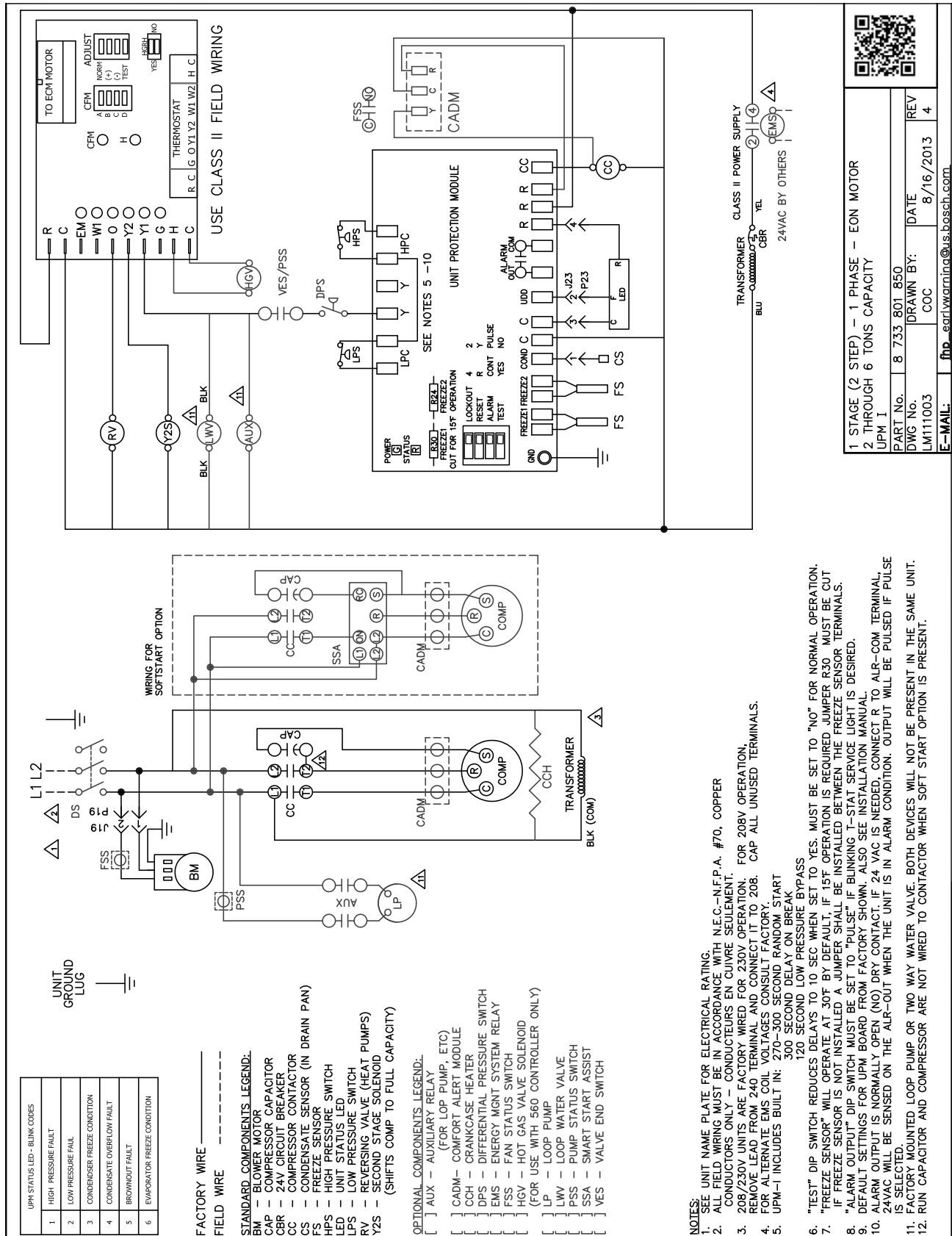

Figure # 28

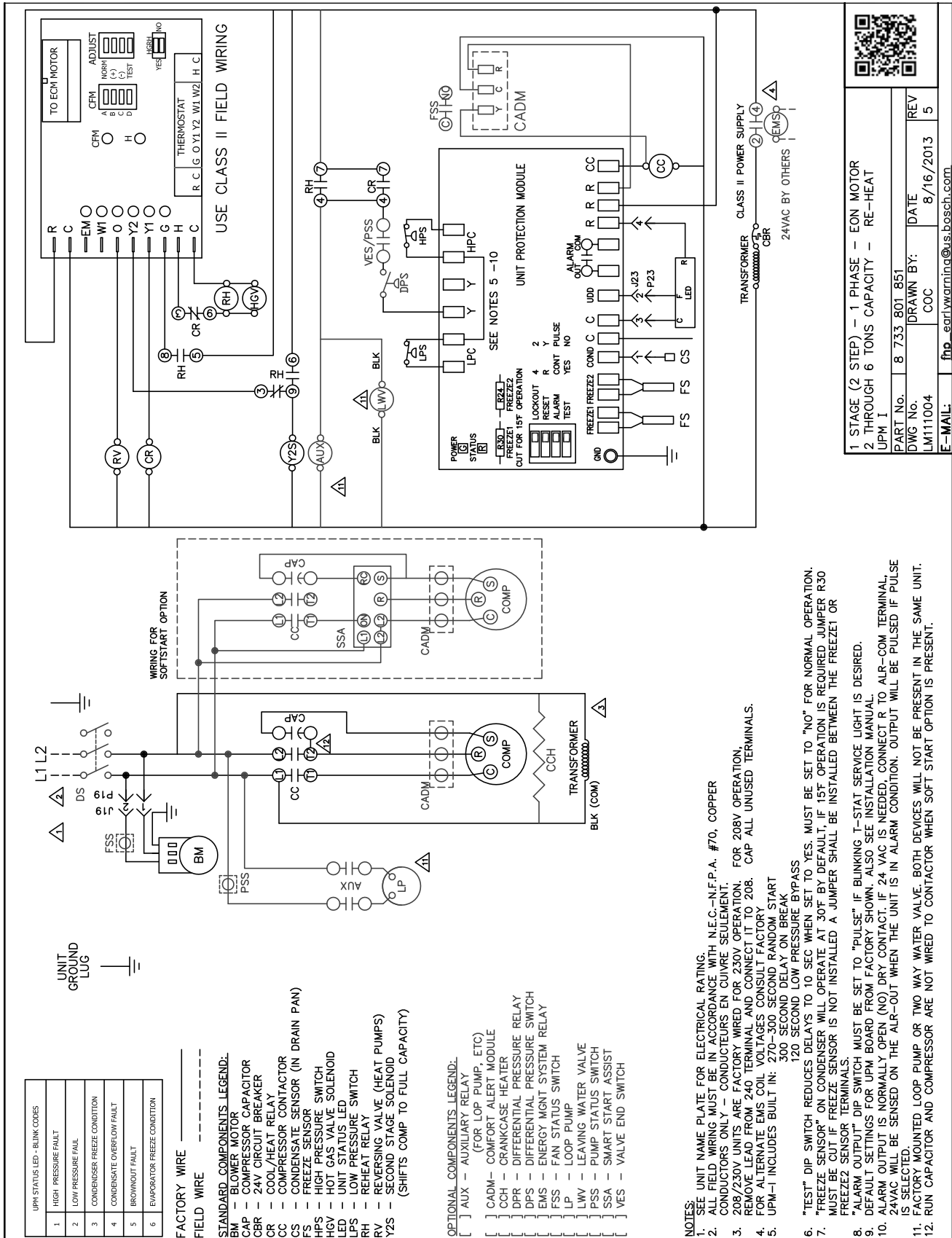



Figure # 29

1 STAGE (2 STEP) - 1 PHASE - EON MOTOR
 2 THROUGH 6 TONS CAPACITY - RE-HEAT UPM I

PART No. 8 733 801 851
 DWG No. LM111004
 DRAWN BY: COC
 DATE: 8/16/2013
 REV: 5

E-MAIL: fhp_earl.ywarrina@us.bosch.com



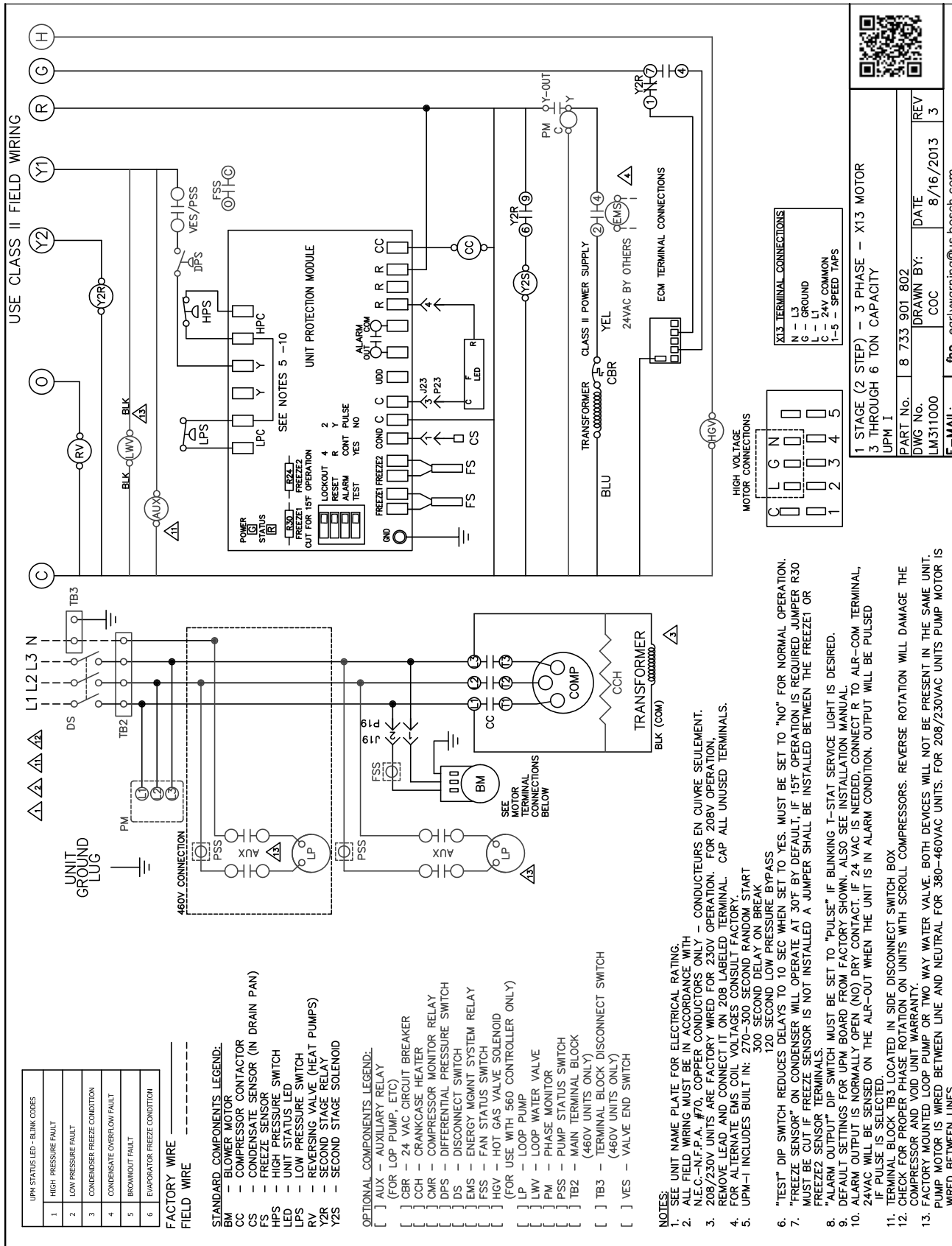

UPM STATUS LED - BLINK CODES	
1	HIGH PRESSURE FAULT
2	LOW PRESSURE FAULT
3	CONDENSER FREEZE CONDITION
4	CONDENSATE OVERFLOW FAULT
5	BROWNOUT FAULT
6	EVAPORATOR FREEZE CONDITION

FACTORY WIRE
FIELD WIRE

STANDARD COMPONENTS LEGEND:
 BM - BLOWER MOTOR
 CC - COMPRESSOR CONTACTOR
 CS - CONDENSATE SENSOR (IN DRAIN PAN)
 FS - FREEZE SENSOR
 HPS - HIGH PRESSURE SWITCH
 LED - UNIT STATUS LED
 LPS - LOW PRESSURE SWITCH
 RV - REVERSING VALVE (HEAT PUMPS)
 Y2R - SECOND STAGE SOLENOID
 Y2S - SECOND STAGE SOLENOID

OPTIONAL COMPONENTS LEGEND:
 [] AUX - AUXILIARY RELAY
 [] CBR - 24 VAC CIRCUIT BREAKER (FOR LOOP PUMP, ETC)
 [] CCH - CRANKCASE HEATER
 [] CCMR - COMPRESSOR MONITOR RELAY
 [] DPS - DIFFERENTIAL PRESSURE SWITCH
 [] DS - DISCONNECT SWITCH
 [] EMS - ENERGY MGMT SYSTEM RELAY
 [] FSS - FAN STATUS SWITCH
 [] HGV - HOT GAS VALVE SOLENOID (FOR USE WITH 560 CONTROLLER ONLY)
 [] LP - LOOP PUMP
 [] LWV - LOOP WATER VALVE
 [] PM - PHASE MONITOR
 [] PSS - PUMP STATUS SWITCH
 [] TB2 - MAIN TERMINAL BLOCK (460V UNITS ONLY)
 [] TB3 - TERMINAL BLOCK DISCONNECT SWITCH (460V UNITS ONLY)
 [] VES - VALVE END SWITCH

- NOTES:**
- SEE UNIT NAME PLATE FOR ELECTRICAL RATING.
 - ALL FIELD WIRING MUST BE IN ACCORDANCE WITH N.E.C.-N.F.P.A. #70, COPPER CONDUCTORS ONLY - CONDUCTEURS EN CUIVRE SEULEMENT.
 - 208/230V UNITS ARE FACTORY WIRED FOR 230V OPERATION. FOR 208V OPERATION, REMOVE LEAD AND CONNECT IT ON 208 LABELED TERMINAL. CAP ALL UNUSED TERMINALS.
 - FOR ALTERNATE EMS COIL VOLTAGES CONSULT FACTORY.
 - UPM-1 INCLUDES BUILT IN: 270-300 SECOND RANDOM START 300 SECOND DELAY ON BREAK 120 SECOND LOW PRESSURE BYPASS
 - "TEST" DIP SWITCH REDUCES DELAYS TO 10 SEC WHEN SET TO YES. MUST BE SET TO "NO" FOR NORMAL OPERATION.
 - "FREEZE SENSOR" ON CONDENSER WILL OPERATE AT 30F BY DEFAULT, IF 15F OPERATION IS REQUIRED JUMPER R30 MUST BE CUT IF FREEZE SENSOR IS NOT INSTALLED A JUMPER SHALL BE INSTALLED BETWEEN THE FREEZE1 OR FREEZE2 SENSOR TERMINALS.
 - "ALARM OUTPUT" DIP SWITCH MUST BE SET TO "PULSE" IF BLINKING T-STAT SERVICE LIGHT IS DESIRED.
 - DEFAULT SETTINGS FOR UPM BOARD FROM FACTORY SHOWN. ALSO SEE INSTALLATION MANUAL.
 - ALARM OUTPUT IS NORMALLY OPEN (NO) DRY CONTACT. IF 24 VAC IS NEEDED, CONNECT R TO ALR-COM TERMINAL. 24VAC WILL BE SENSED ON THE ALR-OUT WHEN THE UNIT IS IN ALARM CONDITION. OUTPUT WILL BE PULSED IF PULSE IS SELECTED.
 - TERMINAL BLOCK TB3 LOCATED IN SIDE DISCONNECT SWITCH BOX
 - CHECK FOR PROPER PHASE ROTATION ON UNITS WITH SCROLL COMPRESSORS. REVERSE ROTATION WILL DAMAGE THE COMPRESSOR AND VOID UNIT WARRANTY.
 - FACTORY MOUNTED LOOP PUMP OR TWO WAY WATER VALVE. BOTH DEVICES WILL NOT BE PRESENT IN THE SAME UNIT.
 - PUMP MOTOR IS WIRED BETWEEN LINE AND NEUTRAL FOR 380-460VAC UNITS. FOR 208/230VAC UNITS PUMP MOTOR IS WIRED BETWEEN LINES.

X13 TERMINAL CONNECTIONS
 N - L3
 G - GROUND
 L - L1
 L - L2
 1-5 - SPEED TAPS

HIGH VOLTAGE MOTOR CONNECTIONS

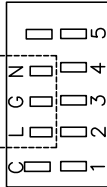

1 STAGE (2 STEP) - 3 PHASE - X13 MOTOR
 3 THROUGH 6 TON CAPACITY
 UPM 1

PART No.	8 733 901 802	DATE	8/16/2013
DWG No.	LM311000	COC	
E-MAIL:	fhp_earlywarning@us.bosch.com		



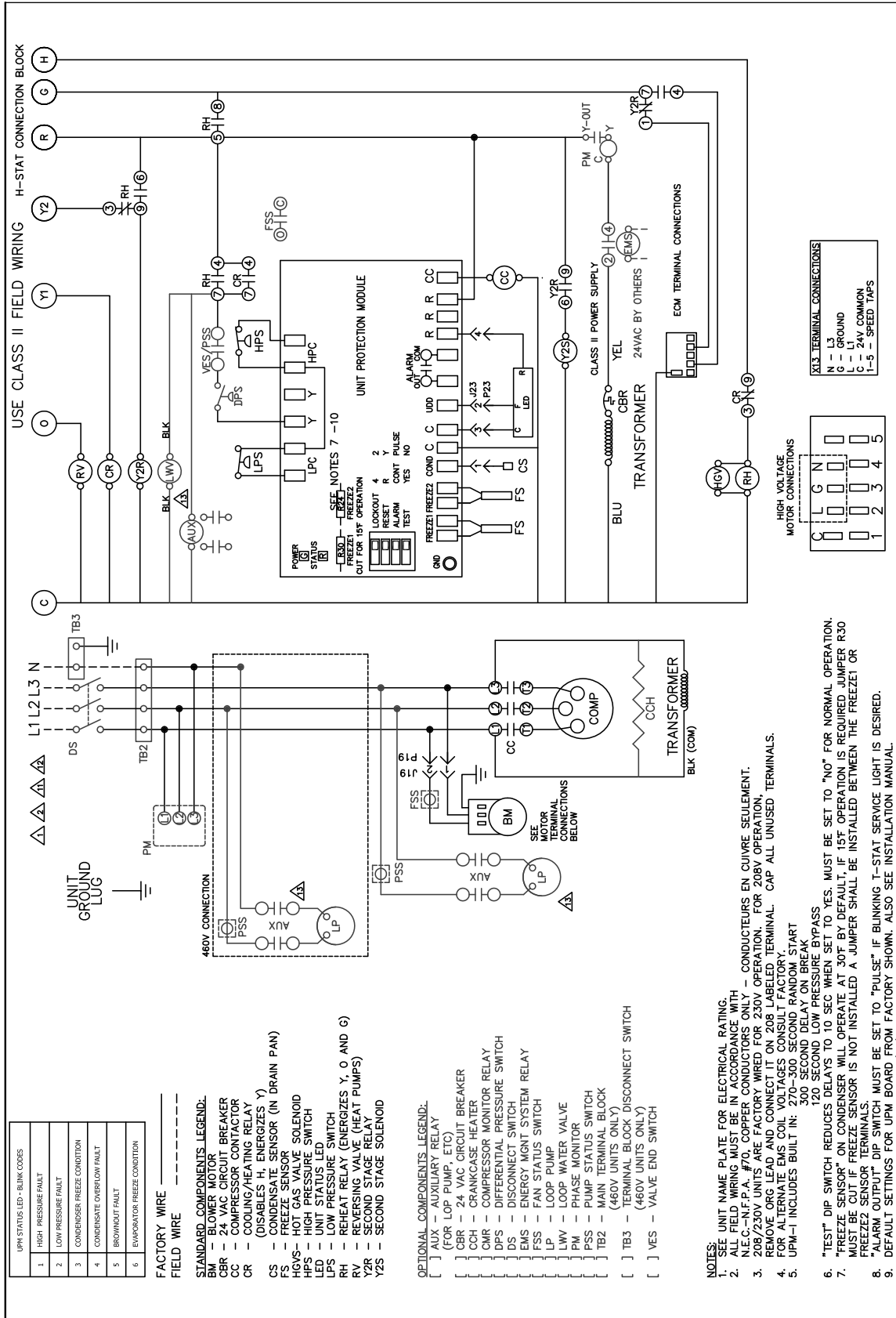

UPM STATUS LED - SLINK CODES
1 HIGH PRESSURE FAULT
2 LOW PRESSURE FAULT
3 CONDENSER FREEZE CONDITION
4 CONDENSATE OVERFLOW FAULT
5 BLOWOUT FAULT
6 EVAPORATOR FREEZE CONDITION

- FACTORY WIRE** -----
FIELD WIRE -----
- STANDARD COMPONENTS LEGEND:**
 BM - BLOWER MOTOR
 CBR - 24 VAC CIRCUIT BREAKER
 CC - COMPRESSOR CONTACTOR
 CR - COOLING/HEATING RELAY (DISABLES H, ENERGIZES Y)
 CS - CONDENSATE SENSOR (IN DRAIN PAN)
 FS - FREEZE SENSOR
 HGVS - HOT GAS VALVE SOLENOID
 HPS - HIGH PRESSURE SWITCH
 LED - UNIT STATUS LED
 LPS - UNIT PRESSURE SWITCH
 RH - REHEAT RELAY (ENERGIZES Y, O, AND G)
 RST - RESTART RELAY (HEAT PUMPS)
 Y2R - SECOND STAGE RELAY
 Y2S - SECOND STAGE SOLENOID

- OPTIONAL COMPONENTS LEGEND:**
 [] AUX - AUXILIARY RELAY (FOR LOP PUMP, ETC)
 [] CBR - 24 VAC CIRCUIT BREAKER
 [] CCH - CRANKCASE HEATER
 [] OMR - COMPRESSOR MONITOR RELAY
 [] DPS - DIFFERENTIAL PRESSURE SWITCH
 [] DS - DISCONNECT SWITCH
 [] EMS - ENERGY MGMT SYSTEM RELAY
 [] FSS - FAN STATUS SWITCH
 [] LP - LOOP PUMP
 [] LWV - LOOP WATER VALVE
 [] PM - PHASE MONITOR
 [] PSS - PUMP STATUS SWITCH
 [] TB2 - MAIN TERMINAL BLOCK (460V UNITS ONLY)
 [] TB3 - TERMINAL BLOCK DISCONNECT SWITCH (460V UNITS ONLY)
 [] YES - VALVE END SWITCH

- NOTES:**
- SEE UNIT NAME PLATE FOR ELECTRICAL RATING.
 - ALL FIELD WIRING MUST BE IN ACCORDANCE WITH N.E.C.-N.F.P.A. #70. COPPER CONDUCTORS ONLY - CONDUCTEURS EN CUIVRE SEULEMENT.
 - 208/230V UNITS ARE FACTORY WIRED FOR 230V OPERATION. FOR 208V OPERATION, REMOVE THE 230V LINE VOLTAGE COIL FROM THE FACTORY WIRING. CAP ALL UNUSED TERMINALS.
 - FOR FIELD WIRING, USE THE FOLLOWING CONVENTIONS:
 UPM-1 INCLUDES BUILT IN: 270-300 SECOND, RANDOM, START 300 SECOND DELAY ON BREAK
 120 SECOND LOW PRESSURE BYPASS
 120 SECOND DELAY ON BREAK
 - "TEST" DIP SWITCH REDUCES DELAYS TO 10 SEC WHEN SET TO YES. MUST BE SET TO "NO" FOR NORMAL OPERATION.
 - "FREEZE SENSOR" ON CONDENSER WILL OPERATE AT 30°F BY DEFAULT. IF 15°F OPERATION IS REQUIRED JUMPER R30 MUST BE CUT IF FREEZE SENSOR IS NOT INSTALLED. A JUMPER SHALL BE INSTALLED BETWEEN THE FREEZEZT OR FREEZEZT SENSOR TERMINALS.
 - "ALARM OUTPUT" DIP SWITCH MUST BE SET TO "PULSE" IF BLINKING T-STAT SERVICE LIGHT IS DESIRED.
 - DEFAULT SETTINGS FOR UPM BOARD FROM FACTORY SHOWN. ALSO SEE INSTALLATION MANUAL.
 - ALARM OUTPUT IS NORMALLY OPEN (NO) DRY CONTACT. IF 24 VAC IS NEEDED, CONNECT R TO AIR-COM TERMINAL. 24VAC WILL BE SENSED ON THE ALR-OUT WHEN THE UNIT IS IN ALARM CONDITION. OUTPUT WILL BE PULSED IF PULSE IS SELECTED.
 - TERMINAL BLOCK TB3 LOCATED IN SIDE DISCONNECT SWITCH BOX
 - CHECK FOR PROPER PHASE ROTATION ON UNITS WITH SCROLL COMPRESSORS. REVERSE ROTATION WILL DAMAGE THE COMPRESSOR AND VOID UNIT WARRANTY.
 - FACTORY MOUNTED LOG PUMP OR TWO WAY WATER VALVE. BOTH DEVICES WILL NOT BE PRESENT IN THE SAME UNIT. PUMP MOTOR IS WIRED BETWEEN LINE AND NEUTRAL FOR 360-460VAC UNITS. FOR 208/230VAC UNITS PUMP MOTOR IS WIRED BETWEEN LINES.

1 STAGE (2 STEP) - 3 PHASE - X13 MOTOR
 3 THROUGH 6 TON CAPACITY - RE-HEAT UPM I

PART No.	B 733 901 803
DATE	8/16/2013
REV	4
DWG No.	LM311001
COC	

E-MAIL: ftp_eartywiring@us.bosch.com

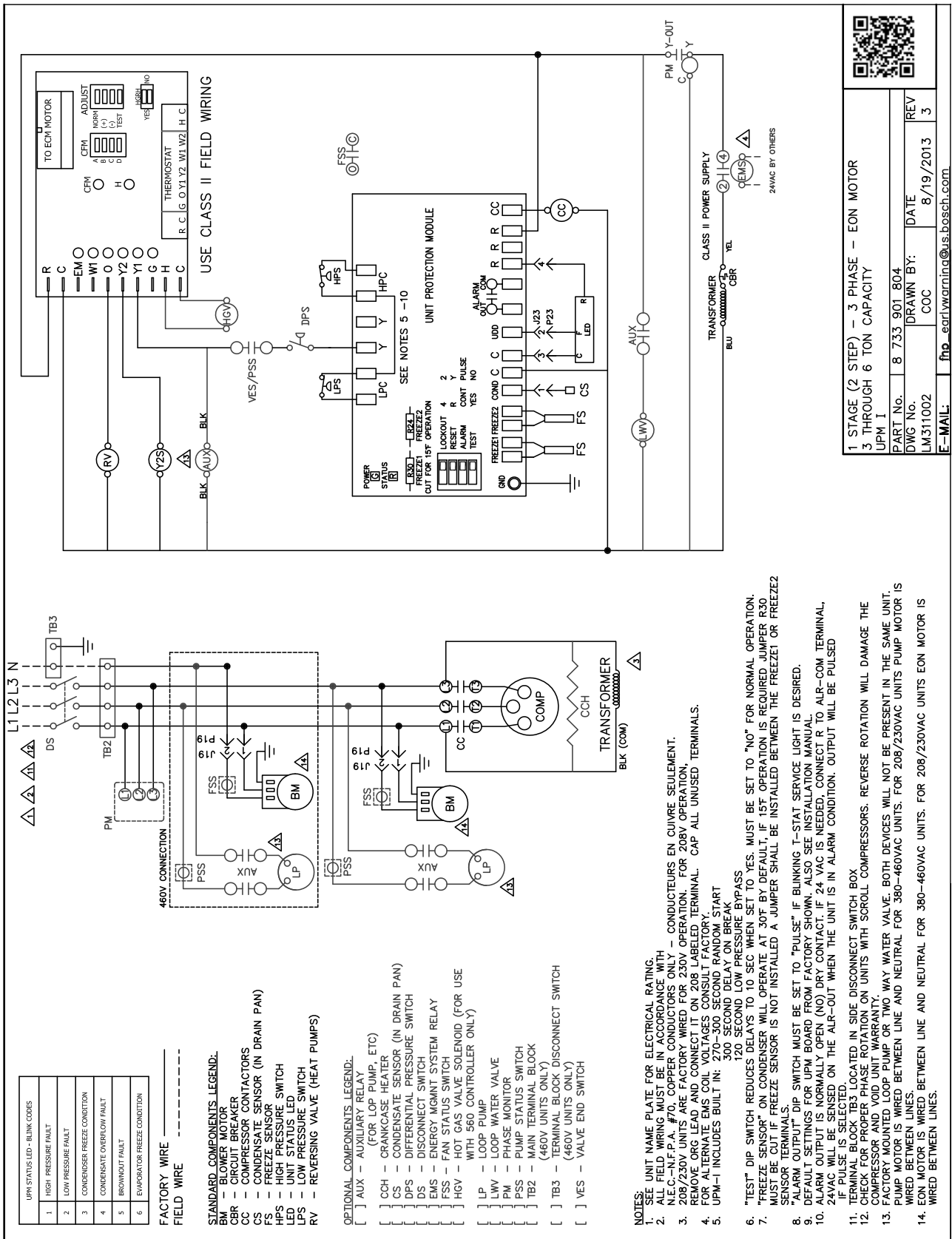

1 STAGE (2 STEP) - 3 PHASE - EON MOTOR	
3 THROUGH 6 TON CAPACITY	
UPM I	
PART No.	8 733 901 804
DWG No.	DATE
LM311002	COC
E-MAIL:	fnp_earlwarmin@us.bosch.com
REV	5

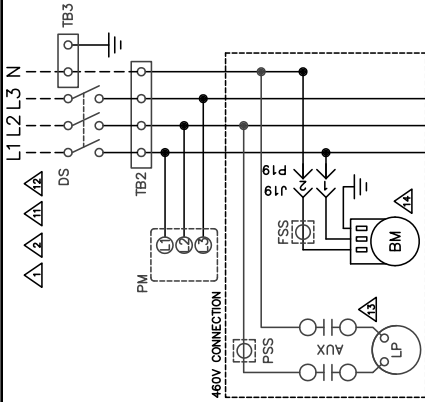

- UPM STATUS LED - BLINK CODES**
- | | |
|----|-----------------------------|
| 1. | HIGH PRESSURE FAULT |
| 2. | LOW PRESSURE FAULT |
| 3. | CONDENSER FREEZE CONDITION |
| 4. | CONDENSATE OVERFLOW FAULT |
| 5. | BLOWNOUT FAULT |
| 6. | EVAPORATOR FREEZE CONDITION |
- FACTORY WIRE** ———
FIELD WIRE - - - - -
- STANDARD COMPONENTS LEGEND:**
- BM - BLOWER MOTOR
 - CBR - CIRCUIT BREAKER
 - CC - COMPRESSOR CONTACTORS
 - CS - CONDENSATE SENSOR (IN DRAIN PAN)
 - FS - FREEZE SENSOR
 - HPS - HIGH PRESSURE SWITCH
 - LED - UNIT STATUS LED
 - LPS - LOW PRESSURE SWITCH
 - RV - REVERSING VALVE (HEAT PUMPS)
- OPTIONAL COMPONENTS LEGEND:**
- [] AUX - AUXILIARY RELAY (FOR LOP PUMP, ETC)
 - [] CCH - CRANKCASE HEATER
 - [] CS - CONDENSATE SENSOR (IN DRAIN PAN)
 - [] DPS - DIFFERENTIAL PRESSURE SWITCH
 - [] DS - DISCONNECT SWITCH
 - [] EMS - ENERGY MGMT SYSTEM RELAY
 - [] FSS - FAN STATUS SWITCH
 - [] HGV - HOT GAS VALVE SOLENOID (FOR USE WITH 560 CONTROLLER ONLY)
 - [] LP - LOOP PUMP
 - [] LWV - LOOP WATER VALVE
 - [] PM - PHASE MONITOR
 - [] PSS - PUMP STATUS SWITCH
 - [] TB2 - MAIN TERMINAL BLOCK (460V UNITS ONLY)
 - [] TB3 - TERMINAL BLOCK DISCONNECT SWITCH (460V UNITS ONLY)
 - [] YES - VALVE END SWITCH

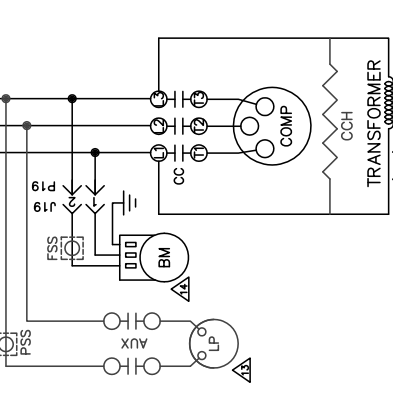

- NOTES:**
- SEE UNIT NAME PLATE FOR ELECTRICAL RATING.
 - ALL FIELD WIRING MUST BE IN ACCORDANCE WITH N.E.C.—N.F.P.A. #70, COPPER CONDUCTORS ONLY — CONDUCTEURS EN CUIVRE SEULEMENT.
 - 208/230V UNITS ARE FACTORY WIRED FOR 230V OPERATION. FOR 208V OPERATION, REMOVE ORG LEAD AND CONNECT IT ON 208 LABELED TERMINAL. CAP ALL UNUSED TERMINALS.
 - FOR ALTERNATE EMS COIL VOLTAGES CONSULT FACTORY.
 - UPM-I INCLUDES BUILT IN: 270-300 SECOND RANDOM START 300 SECOND DELAY ON BREAK 120 SECOND LOW PRESSURE BYPASS
 - "TEST" DIP SWITCH REDUCES DELAYS TO 10 SEC WHEN SET TO "YES. MUST BE SET TO "NO" FOR NORMAL OPERATION.
 - "FREEZE SENSOR" ON CONDENSER WILL OPERATE AT 30°F BY DEFAULT. IF 15°F OPERATION IS REQUIRED JUMPER R30 MUST BE CUT IF FREEZE SENSOR IS NOT INSTALLED A JUMPER SHALL BE INSTALLED BETWEEN THE FREEZE1 OR FREEZE2 SENSOR TERMINALS.
 - "ALARM OUTPUT" DIP SWITCH MUST BE SET TO "PULSE" IF BLINKING I-STAT SERVICE LIGHT IS DESIRED.
 - DEFAULT SETTINGS FOR UPM BOARD FROM FACTORY SHOWN. ALSO SEE INSTALLATION MANUAL.
 - ALARM OUTPUT IS NORMALLY OPEN (NO) DRY CONTACT. IF 24 VAC IS NEEDED, CONNECT R TO ALR-COM TERMINAL. 24VAC WILL BE SENSED ON THE ALR-(NOT) WHEN THE UNIT IS IN ALARM CONDITION. OUTPUT WILL BE PULSED
 - TERMINAL BLOCK TB3 IS LOCATED IN SIDE DISCONNECT SWITCH BOX
 - CHECK FOR PROPER PHASE ROTATION ON UNITS WITH SCROLL COMPRESSORS. REVERSE ROTATION WILL DAMAGE THE COMPRESSOR AND VOID UNIT WARRANTY.
 - FACTORY MOUNTED LOOP PUMP OR TWO WAY WATER VALVE. BOTH DEVICES WILL NOT BE PRESENT IN THE SAME UNIT. PUMP MOTOR IS WIRED BETWEEN LINE AND NEUTRAL FOR 380-460VAC UNITS. FOR 208/230VAC UNITS PUMP MOTOR IS WIRED BETWEEN LINES.
 - EON MOTOR IS WIRED BETWEEN LINE AND NEUTRAL FOR 380-460VAC UNITS. FOR 208/230VAC UNITS EON MOTOR IS WIRED BETWEEN LINES.

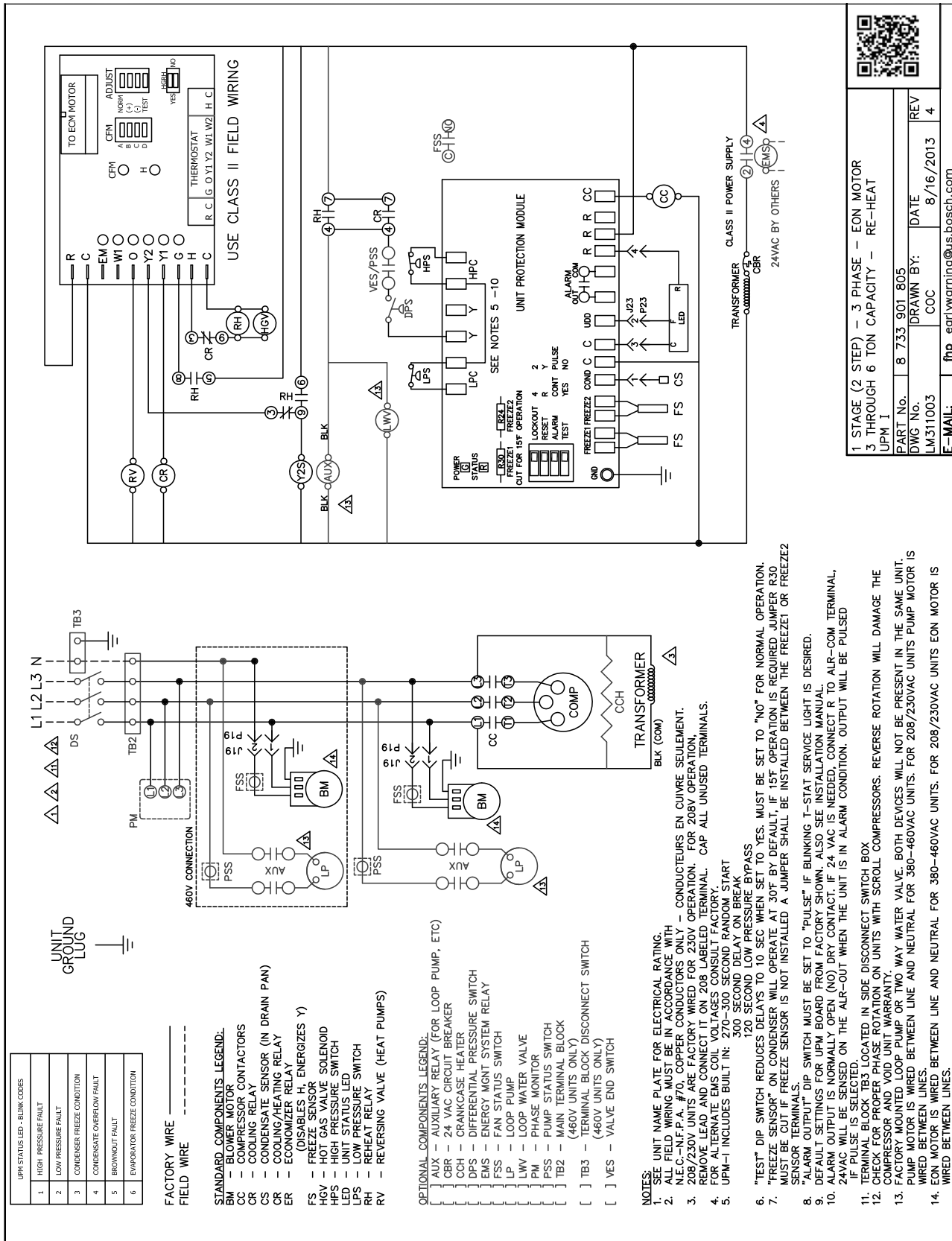

1 STAGE (2 STEP) — 3 PHASE — EON MOTOR	
3 THROUGH 6 TON CAPACITY — RE-HEAT UPM I	
PART No.	8 733 901 805
DWG No.	LM311003
DATE	8/16/2013
REV	4
E-MAIL: ftp_eorlywarrino@us.bosch.com	

Figure # 31

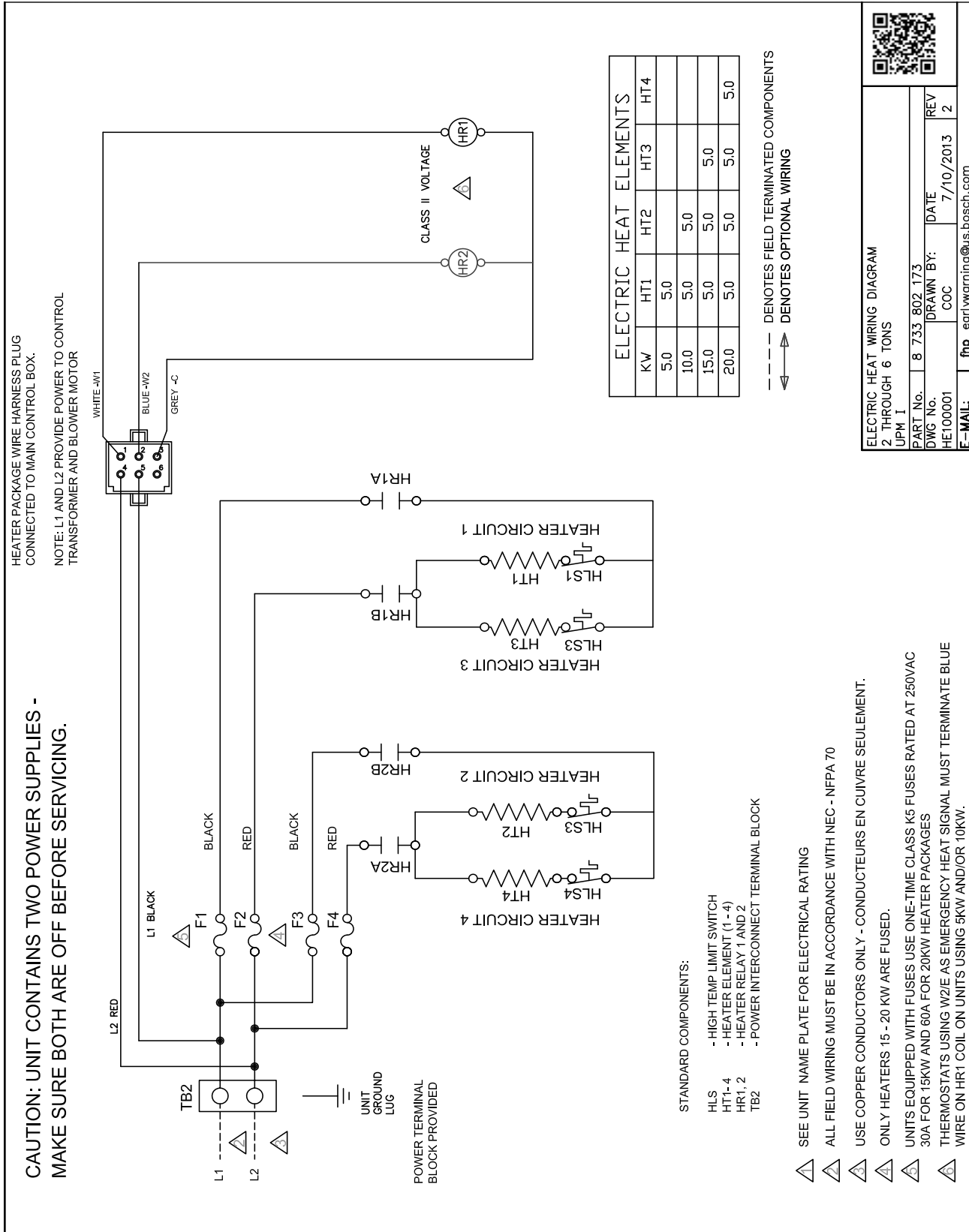

Figure # 32

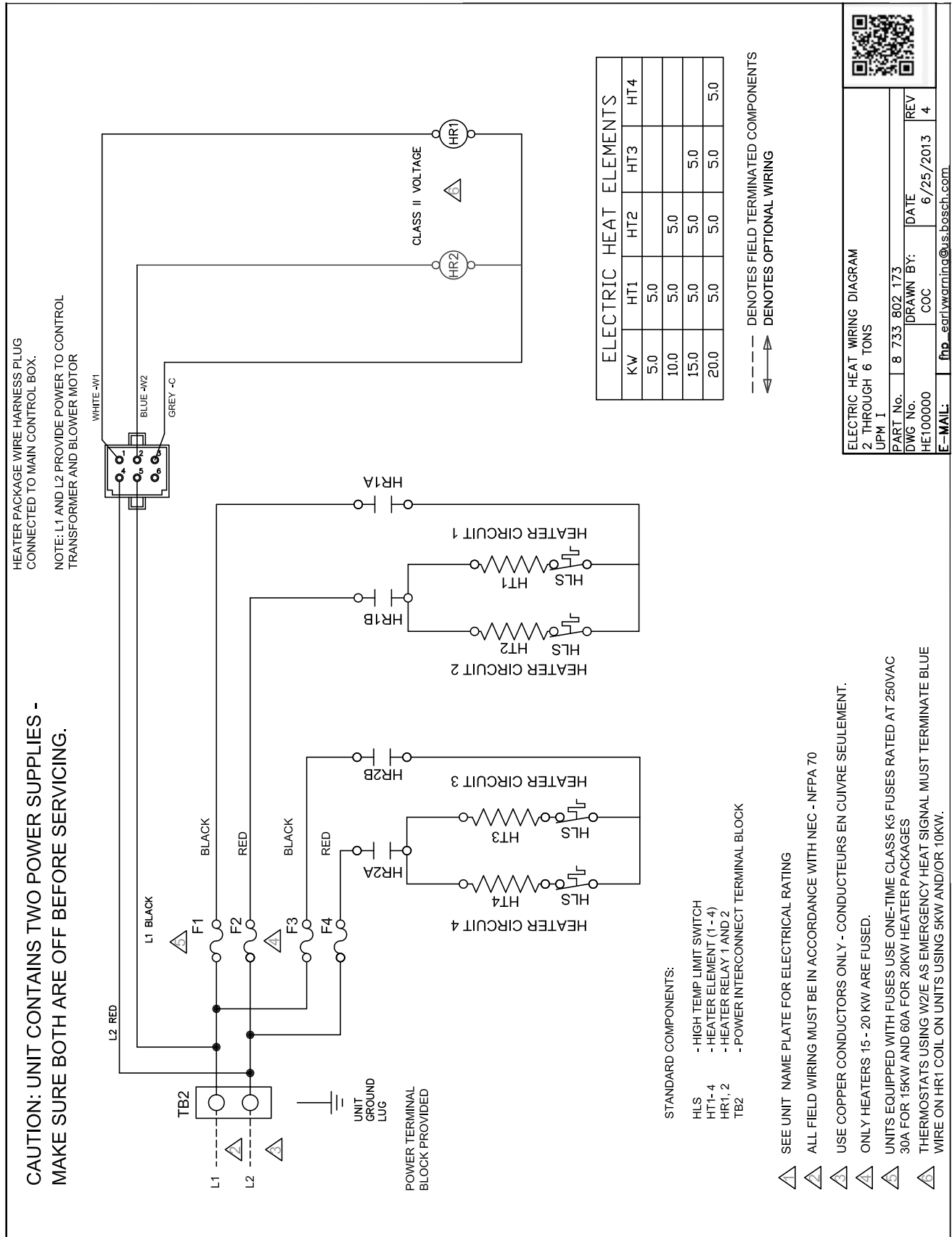
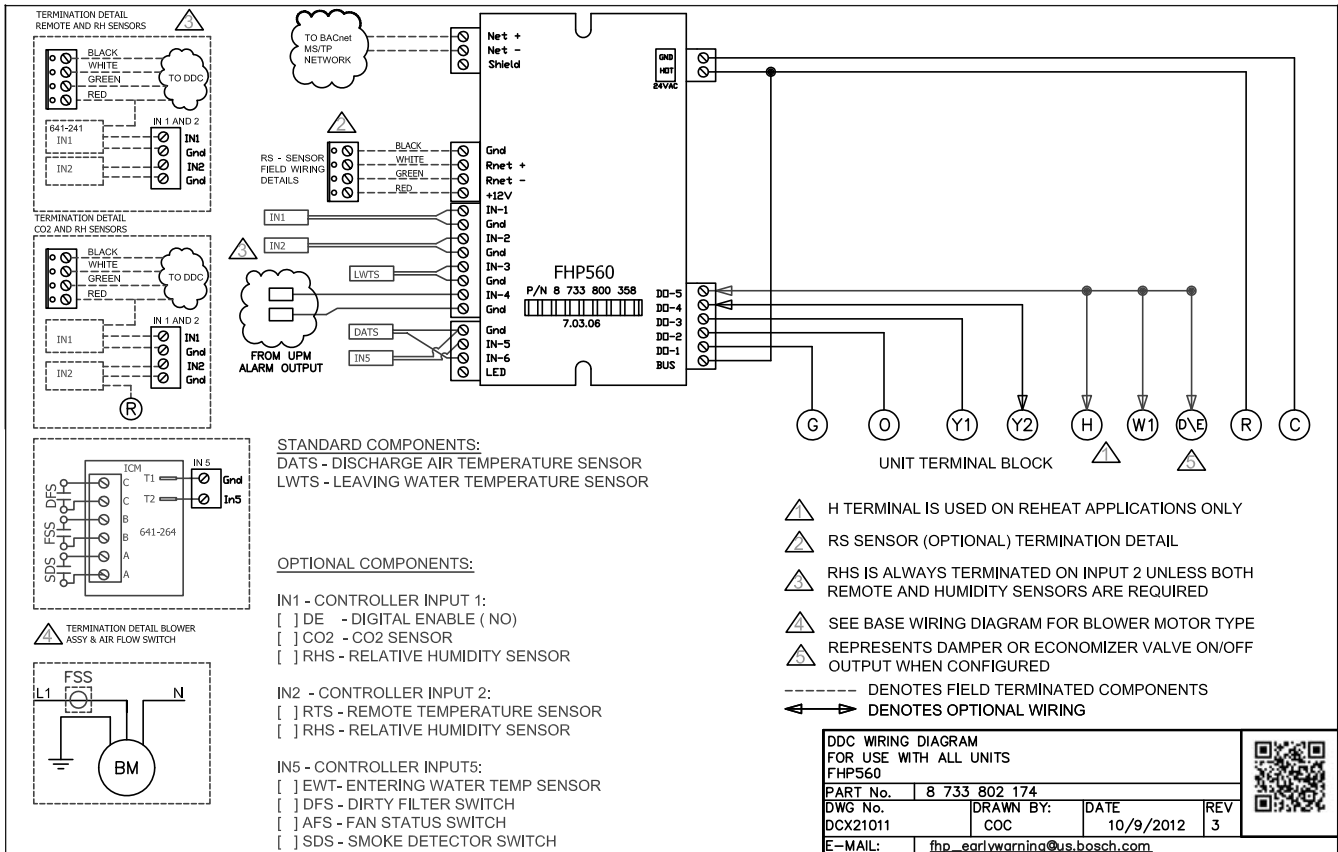

Figure # 33

ELECTRIC HEAT WIRING DIAGRAM
 2 THROUGH 6 TONS
 UPM 1

PART No. 8 733 802 173
 DWG No. HE100000
 DRAWN BY: []
 DATE: 6/25/2013
 COC: []
 REV: 4

E-MAIL: fnp_earlwarnina@us.bosch.com



SCHNITT-HIER / CUT HERE / CORTA AQUI

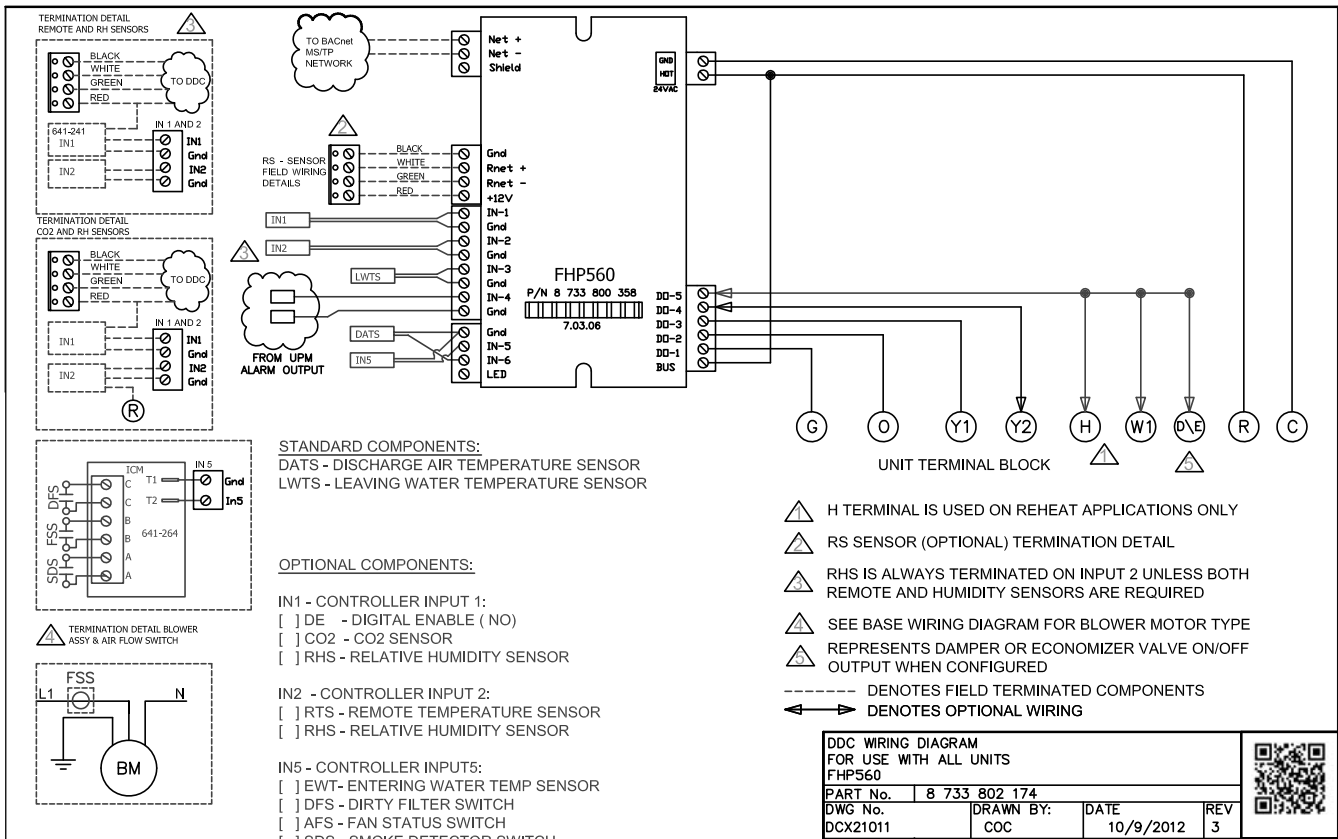

Figure # 34

WIRING HARNESS DRAWINGS

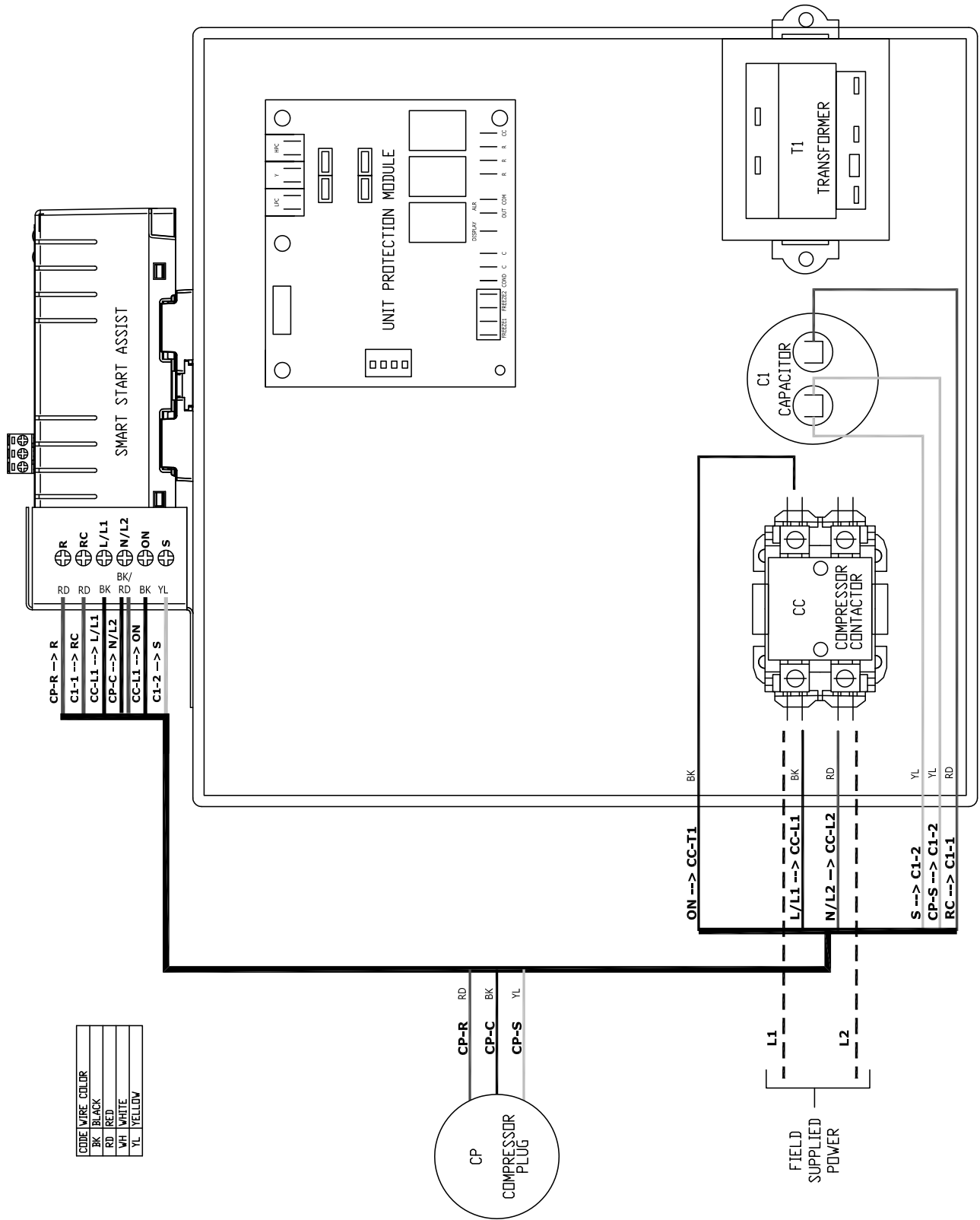

Figure # 35 Three Phase

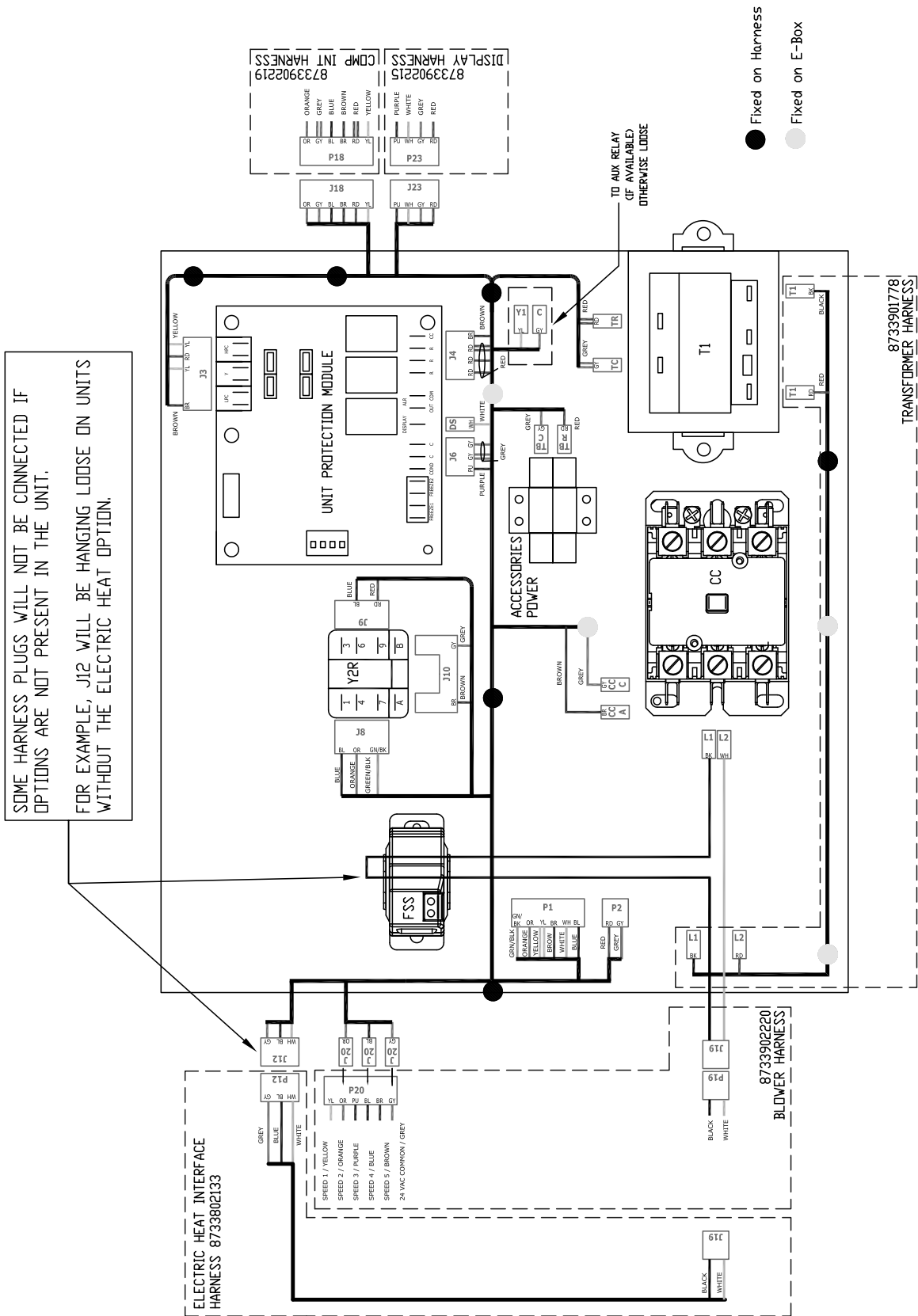

Figure # 36 Three Phase

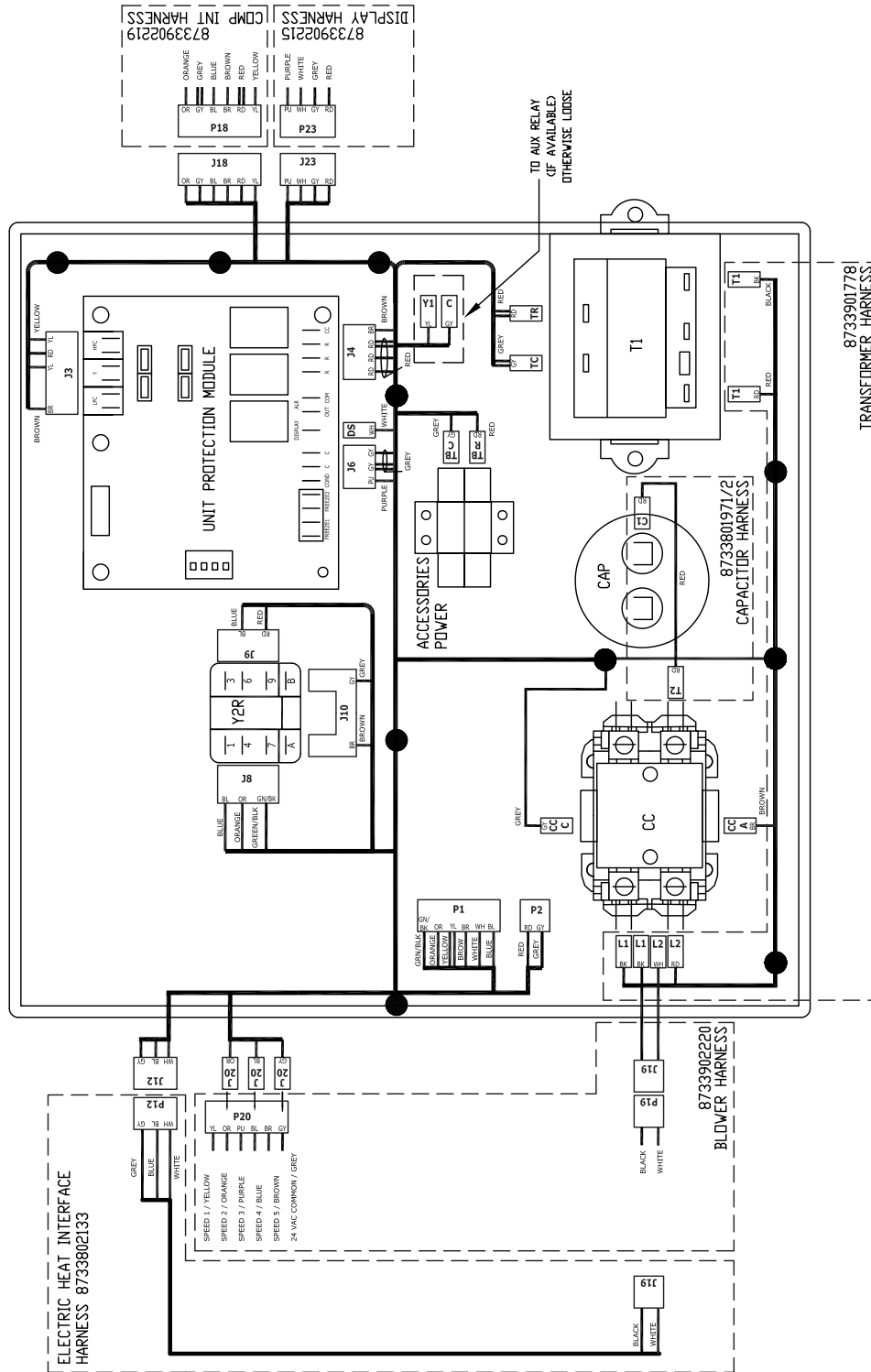

Figure # 37 Single Phase

DIMENSIONAL DRAWINGS

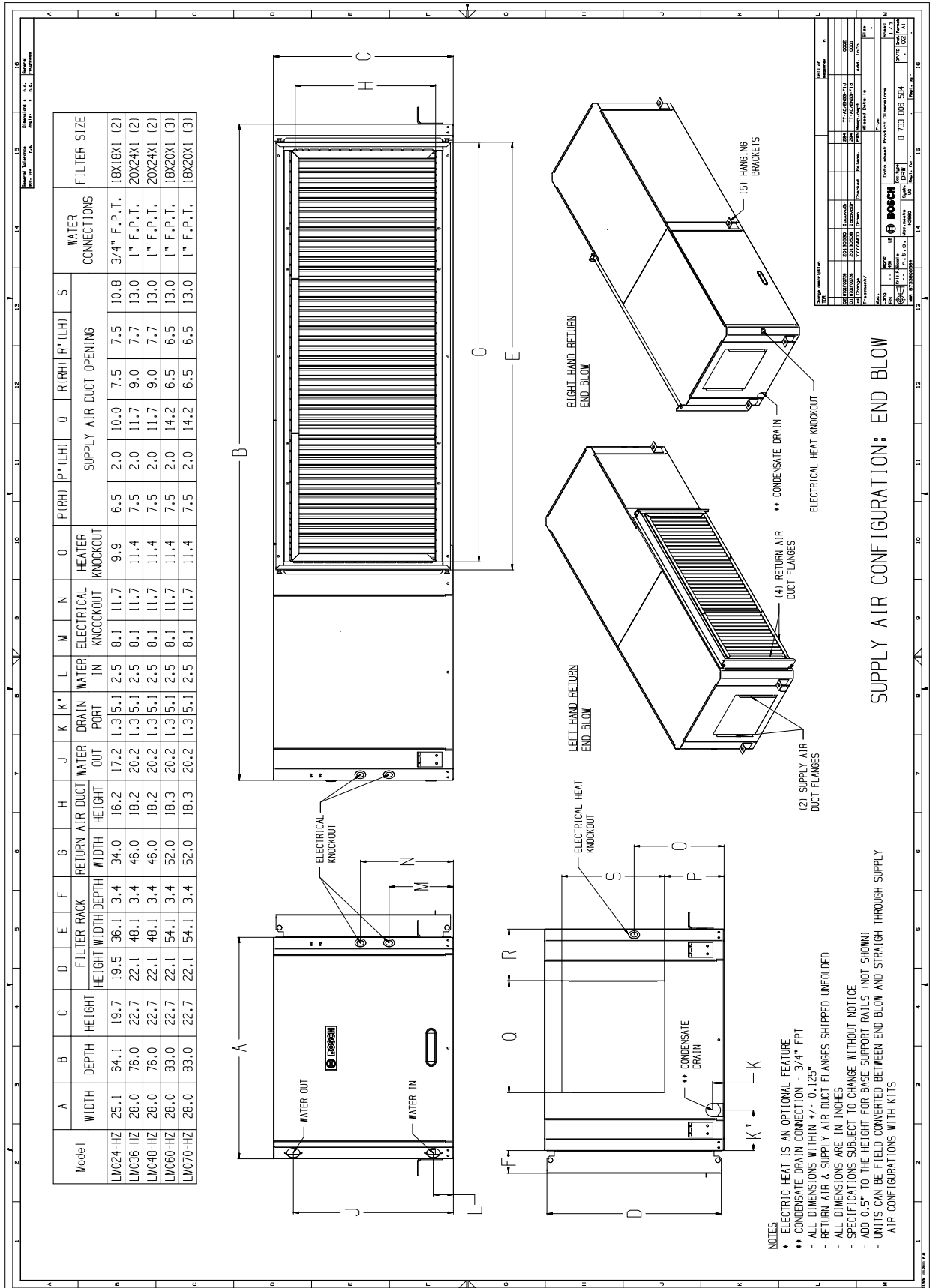
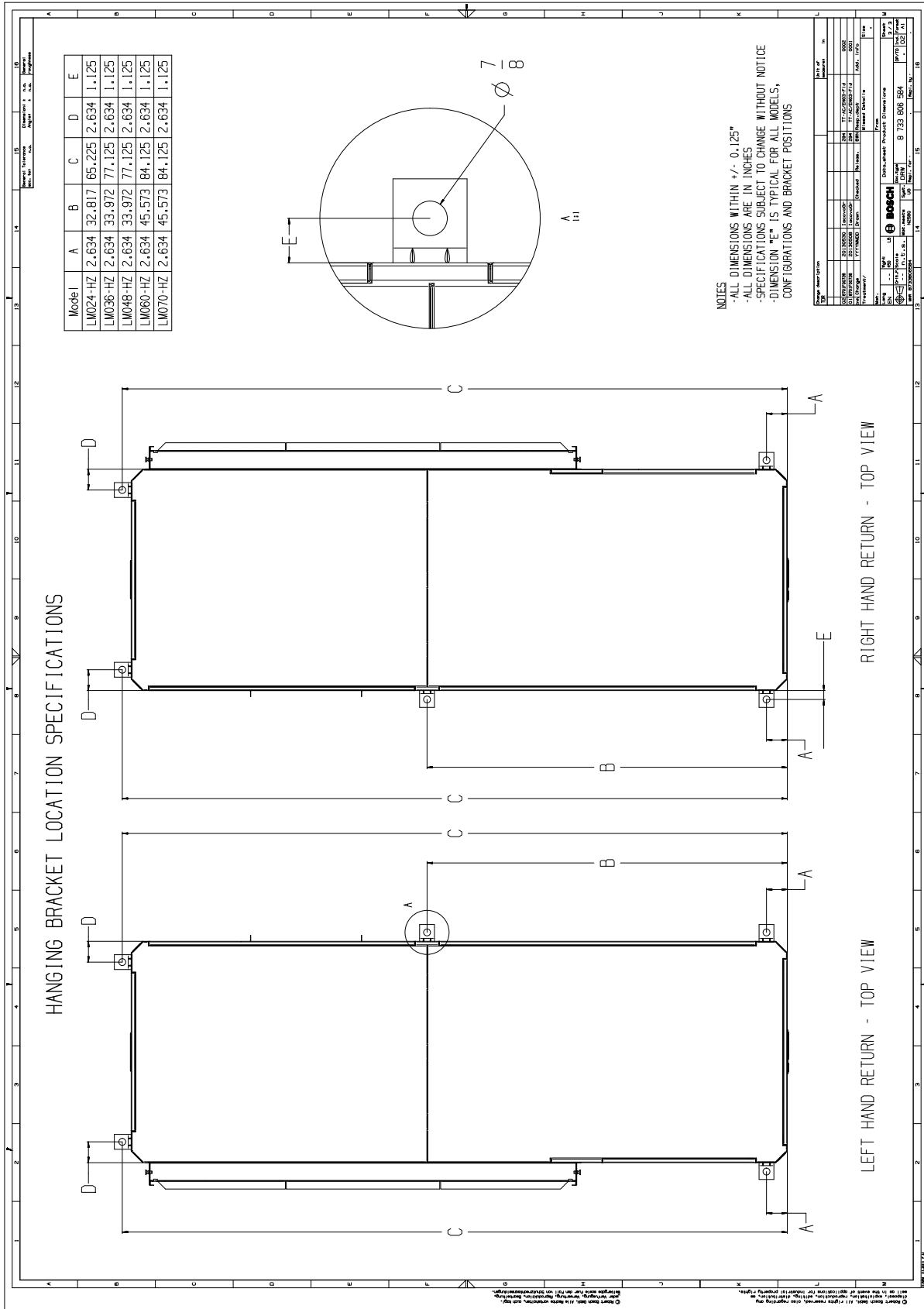

Figure # 39

Horizontal - Hanging bracket location



NOTES



BOSCH

601 N.W. 65th Court, Ft. Lauderdale, FL 33309
Phone: 866-642-3198 | Fax: 954-776-5529
www.boshtaxcredit.com | www.bosch-climate.us
Revised 09-13

