



GreenSource i Series BC Model Console



BOSCH

Installation, Operation and Maintenance Manual

8733942457 (2016/04)

CONTENTS

Model Nomenclature.....	3	Standard Length.....	23
Key to Symbols.....	4	Extended Length.....	24
Safety Warnings.....	4	Unit Check-Out Sheet	25
Standard Package.....	5	Customer Data.....	25
Initial Inspection.....	5	Unit Nameplate Data.....	25
General Description.....	5	Operating Conditions.....	25
Moving and Storage	5	Auxiliary Heat	25
Location.....	5	Maintenance.....	26
Installation.....	6	Information On Decommissioning.....	26
Piping	6	Terminology	27
Supply and Return Piping.....	6		
Condensate Piping.....	6		
Hose Kits.....	6		
Electrical	7		
Safety Devices and the UPM Controller	7		
CUC Solid State (Console Unit Controller).....	9		
Application considerations.....	10		
Well Water Systems	10		
Ground Water Loop Applications.....	10		
Water Quality.....	11		
Water Quality Table.....	12		
UPM Sequence of Operation.....	13		
Sequence of Operation	14		
Cooling Mode	14		
Heating Mode.....	14		
Cooling Tower/Boiler Systems.....	14		
Geothermal (Earth-Coupled) Systems	14		
System Checkout.....	14		
Unit Start-up	15		
Troubleshooting	15		
Blower Performance Data.....	17		
PSC Motor (Electrical Data Table-PSC Blower Motor).....	18		
Water Side Pressure Drop.....	18		
Operating Temperatures & Pressures.....	19		
Wiring diagrams	20		
Schematic.....	22		
Dimensions.....	23		

MODEL NOMENCLATURE

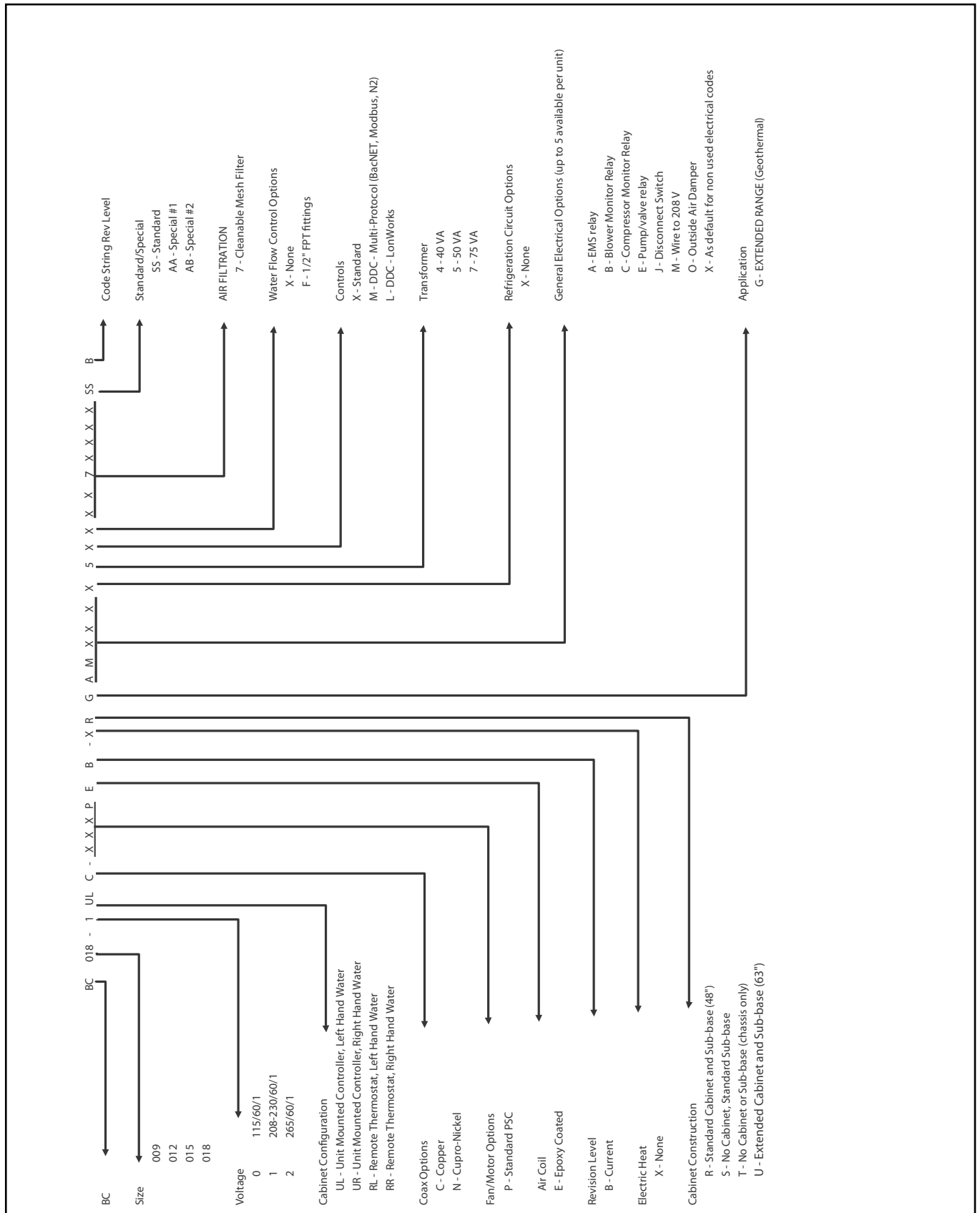

Figure # 1

KEY TO SYMBOLS

Warnings



Warnings in this document are identified by a warning triangle printed against a grey background. Keywords at the start of a warning indicate the type and seriousness of the ensuing risk if measures to prevent the risks are not taken.

The following keywords are defined and can be used in this document:

- **NOTICE** Indicates a situation that could result in damage to property or equipment.
- **CAUTION** Indicates a situation that could result in minor to medium injury.
- **WARNING** Indicates a situation that could result in severe injury or death.
- **DANGER** Indicates a situation that will result in severe injury or death.

Important Information



This symbol indicates important information where there is no risk to property or people.

SAFETY WARNINGS

NOTICE: This unit is design to be operated with the cabinet, sub base and filter in place. Never operate unit with open access panels Doing so can expose the operator to hazardous voltage, moving parts and can damage the equipment.



WARNING: Installation and servicing of this equipment can be hazardous due to system pressure and electrical components. Only trained and qualified personnel should install, repair, or service the equipment.



DANGER: Before performing service or maintenance operations on the system, turn off main power to the unit. On units with mounted controls, the On/Off switch DOES NOT disconnect the unit from main power. High voltage components or moving parts will cause injury or death.



CAUTION: When working on equipment, always observe precautions described in the literature, tags, and labels attached to the unit. Follow all safety codes. Wear safety glasses and work gloves. Use a quenching cloth for brazing, and place a fire extinguisher close to the work area.

NOTICE: All refrigerant discharged from this unit must be recovered WITHOUT EXCEPTION. Technicians must follow industry accepted guidelines and all local, state, and federal statutes for the recovery and disposal of refrigerants. If a compressor is removed from this unit, refrigerant circuit oil will remain in the compressor. To avoid leakage of compressor oil, refrigerant lines of the compressor must be sealed after it is removed.

NOTICE: To avoid the release of refrigerant into the atmosphere, the refrigerant circuit of this unit must be serviced only by technicians who meet local, state, and federal proficiency requirements.

NOTICE: To avoid equipment damage, DO NOT use these units as a source of heating or cooling during the construction process. Doing so may affect the unit's warranty.

The mechanical components and filters will quickly become clogged with construction dirt and debris, which may cause system damage.

STANDARD PACKAGE

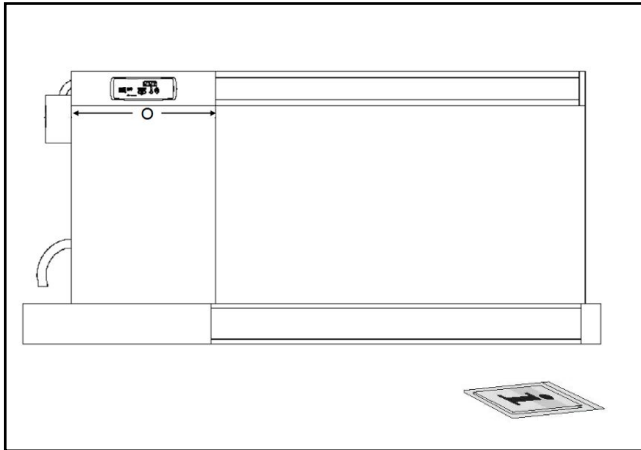

Figure # 2

- [1] BC Model Water-to-Air Heat Pump
[2] Installation and Operation Manual

INITIAL INSPECTION

Please inspect the product carefully for any defects or discrepancies. Should you identify any issue, contact the Bosch Wholesaler / Distributor you purchased the unit from.

GENERAL DESCRIPTION

BC Model Water source Heat Pumps are designed for use as decentralized room terminals that are field connected to a closed-circuit piping loop within a structure. Typically these units are installed in perimeter zones and are ideal for installations where ducted systems are impractical.

BC Series provide the best combination of performance and efficiency available. Safety devices are built into each unit to provide the maximum system protection possible when properly installed and maintained. All units are designed for boiler/tower systems geothermal closed loop applications and can operate with fluid temperatures as low as 25°F in heating and as high as 110°F in cooling. Units are available in 3/4, 1, 1-1/4 and 1-1/2 tons nominal capacity in cooling. Refer to the unit specification sheet for precise performance figures at various entering air and water conditions. All BC water to Air Heat Pumps conform to UL1995 standard and are certified to CAN/CSA C22.2 No 236 by Intertek-ETL.



Heat Pump operating under extreme conditions will have limitations on air/fluid flow rates and/or temperatures.



50° Minimum Entering Water Temperature (EWT) for well water applications with sufficient water flow to prevent freezing. Antifreeze solution is not required for all closed loop applications. Cooling Tower/Boiler and Geothermal applications should have sufficient antifreeze solution to protect against extreme conditions and equipment failure. Frozen water coils are not covered under warranty.

NOTICE: This product should not be used for temporarily heating/cooling during construction. Doing so may Affect the units warranty.

MOVING AND STORAGE

If the equipment is not needed for immediate installation upon its arrival at the job site, it should be left in its shipping carton and stored in a clean, dry area. Units must only be stored or moved in the normal upright position as indicated by the “UP” arrows on each carton at all times.



CAUTION: Do not stack units.

Take care when moving the unit 's weight is located on the left (compressor) end. Always store and move unit in an upright position. Take care to protect the unit cabinet and sub base when moving or storing. Never move or lift unit by its water connections. Units must be moved and stored in an upright position, never lay the unit on it's side.

LOCATION

Locate the unit in an indoor area that allows easy removal of the filter and access panels, and has enough room for service personnel to perform maintenance or repair. Provide sufficient room to make fluid, electrical connection(s). If the unit is located in a confined space, provisions must be made for return air to freely enter the unit's. Allow adequate room below the unit for a condensate drain trap and do not locate the unit above supply piping.

NOTICE: These units are not approved for outdoor installation; therefore, they must be installed inside the structure being conditioned space. Do not locate in areas that are subject to freezing.

INSTALLATION

Before installing the unit, examine each pipe, fitting and valve; remove any dirt or debris found on or in these components. Use care when installing the system components to avoid damage to the cabinet finish or chassis.

1. After removing the console unit from its packaging remove the cabinet by removing the cabinet screws on either side of the unit and lifting the cabinet off the chassis. Set the cabinet aside and cover it (the console unit's packaging can be used for this purpose).
2. Position the sub base directly on the finished floor. Make sure the sub base is level (use shims if necessary). The sub base has a frame that supports the cabinet and may be secured to wall.
3. Position the chassis onto the sub base. Check and align electrical, water and condensate connections and secure to the sub base with 4 screws.
4. Before connecting the unit to water, make sure that the loop has been properly flushed. After flushing the system, connect piping or hoses to the proper supply, return and condensate connections. Refer to the piping section of this manual for more information
5. Make all necessary electrical connections to the unit.



Refer to the unit wiring diagram and the Electrical section of this manual.



DANGER: When making electrical connections to the unit make sure that the power is disconnected. Failure to disconnect power before connecting power wiring to the unit will result in serious injury or death and damage to the unit.

6. Make sure the unit's washable filter is clean and installed in the sub base. Also make sure that the filter clip is in place.
7. Reinstall the unit cabinet via locating pins at the top of the chassis and two screws in the unit sub base.

PIPING:

Supply and Return Piping

The following items should be adhered to in addition to applicable piping codes.

- A drain valve at the base of each riser to enable proper flushing of the system at startup and during servicing.
- Shut-off/Isolation ball valves at the supply and return connections and unions at each unit to permit proper flow balancing and unit servicing.
- Strainers at the inlet of each circulating pump.
- Use of teflon tape on threaded pipe fittings to eliminate water leaks and ensure against air entering the system.
- Flexible hose connections between the unit and the rigid system to eliminate the possibility of vibration transmission through the piping.
- Insulation is not normally required on supply and return piping for boiler tower installations except in unheated sections or outdoor runs.
- Insulation is required for closed-loop.
- Geo-thermal installations as loop temperatures may fall below the dew point and can even fall below the freezing point of water during heating season.

Condensate Piping

Console units are designed with a blow-through configuration in the air handling section. This means that there is positive pressure at the unit drain pan and thus trapping is not required. Condensate is routed from the drain pan via a 5/8" non-pressure rated vinyl hose that is located below the supply and return water connections.

Though horizontal runs of condensate piping are usually too short to pose problems, horizontal runs should be pitched at least 1 inch for every 10 feet of piping. Avoid low spots or no sloped piping, as these areas can collect sediment and eventually block condensate flow. Always inspect both internal and external condensate piping for kinks that could block condensate flow.

Hose Kits

When using optional hose kits follow the manufacturer's recommendations for installation. Never stretch or twist hoses and never use hoses that show external wear or damage or are suspected of having damage. Never exceed the manufacturer's maximum working pressure recommendations.

ELECTRICAL

Field wiring must comply with local and national fire, safety and electrical codes. Power to the unit must be within the operating voltage range indicated on the unit chassis nameplate or the performance data sheet. Properly sized fuses or HACR breakers must be installed for branch circuit protection. See unit chassis name plate for maximum size.

Each chassis is supplied with a 2 x 4 junction box for power connection. Inside this box there are 2 pigtail leads for power wiring. The field ground is to be connected to the ground connection on the junction box. On remote thermostat and master/slave units there are also 5 position terminal blocks for low voltage thermostat or slave unit connection. On remote thermostat units, connect the thermostat wires to the low voltage terminal block. On master/slave units connect the thermostat to the “Master” terminal block of the lead unit and the “Slave” terminal block to the “Master” terminal block of the next unit, daisy chaining the units together as required. Note that there is no limit to the number of units that can be connected together in this manner as each unit provides it’s own low voltage power supply.



WARNING: Use only copper conductors for field installed electrical wiring. Always make sure that the power disconnect is open before performing service on the unit electrical circuits.



All 208/230 volt (-1 voltage code) units are factory wired to 230 volts unless ordered otherwise. In 208 voltage applications the transformer wiring may need to be switched from the 230 volt tap to the 208 volt tap. Cap all unused leads.

SAFETY DEVICES AND THE UPM CONTROLLER

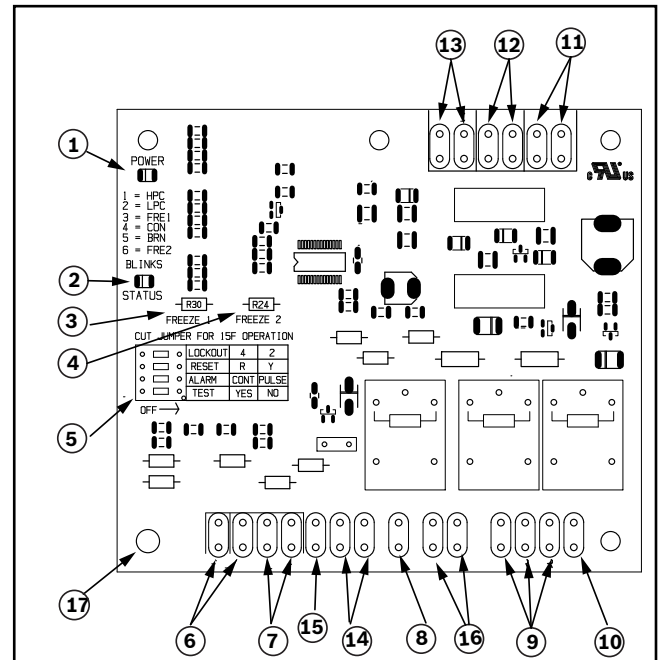

Figure # 3

- [1] Board Power Indicator
- [2] UPM Status LED Indicator
- [3] Water Coil Freeze Protection Temperature Selection [R30]
- [4] Air Coil Freeze Protection Temperature Selection
- [5] UPM Board Settings
- [6] Water Coil Freeze Connection (Freeze 1)
- [7] Air Coil Freeze Connection (Freeze 2)
- [8] LCD Unit Display Connection
- [9] 24VAC Power Input
- [10] Compressor Contact Output
- [11] High Pressure Switch Connection
- [12] Call for Compressor Y1
- [13] Low Pressure Switch Connection
- [14] 24VAC Power Common
- [15] Condensate Overflow Sensor
- [16] Dry Contact/Alarm ALR Contact
- [17] UPM Ground Standoff



If the unit is being connected to a thermostat with a malfunction light, this connection is made at the unit malfunction output or relay.

Units for remote Thermostat applications are provided with a Unit Protection Module (UPM) that controls the compressor operation and monitors the safety controls that protect the unit.

Safety controls include the following:

- High pressure switch located in the refrigerant discharge line and wired across the HPC terminals on the UPM
- Low pressure switch located in the unit refrigerant suction line and wired across terminals LPC1 and LPC2 on the UPM.



UPM Board Dry Contacts are Normally Open (NO)

- Water side freeze protection sensor, mounted close to condensing water coil, monitors refrigerant temperature between condensing water coil and thermal expansion valve. If temperature drops below or remains at freeze limit trip for 30 seconds, the controller will shut down the compressor and enter into a soft lockout condition. The default freeze limit trip is 26°F, however this can be changed to 15°F by cutting the R30 resistor located above the UPM board settings. (See Figure # 3))
- The condensate overflow protection sensor is located in the drain pan of the unit and connected to the 'COND' terminal on the UPM board. (Figure #3)

UPM Board Factory Default Settings	
TEMP	26°F
LOCKOUT	2
RESET	Y
ALARM	PULSE
TEST	NO
HOT/DRY ALARM	NO

UPM DIP SWITCH DEFAULT POSITION			
	lockout	4	2
	reset	R	Y
	alarm	Cont	pulse
	test	yes	no

The UPM Board includes the following features:

- **ANTI-SHORT CYCLE TIMER:** 5 minute delay on break timer to prevent compressor short cycling.

- **RANDOM START:** Each controller has an unique random start delay ranging from 270 to 300 seconds on initial power up to reduce the chance of multiple unit simultaneously starting at the same time after power up or after a power interruption, thus avoiding creating large electrical spike.
- **LOW PRESSURE BYPASS TIMER:** If the compressor is running and the low pressure switch opens, the controller will keep the compressor ON for 120 seconds. After 2 minutes if the low pressure switch remains open, the controllers will shut down the compressor and enter a soft lockout. The compressor will not be energized until the low pressure switch closes and the anti-short cycle time delay expires. If the low pressure switch opens 2-4 times in 1 hour, the unit will enter a hard lockout. In order to exit hard lockout, power to the unit would need to be reset.
- **BROWNOUT/SURGE/POWER INTERRUPTION PROTECTION:** The brownout protection in the UPM board will shut down the compressor if the incoming power falls below 18 VAC. The compressor will remain OFF until the voltage is above 18 VAC and ANTI-SHORT CYCLE TIMER (300 seconds) times out. The unit will not go into a hard lockout and does not need to be reset.
- **MALFUNCTION OUTPUT:** Alarm output is Normally Open (NO) dry contact. If pulse is selected the alarm output will be pulsed. The fault output will depend on the dip switch setting for "ALARM". If it is set to "CONST", a constant signal will be produced to indicate a fault has occurred and the unit requires inspection to determine the type of fault. If it is set to "PULSE", a pulse signal is produced and a fault code is detected by a remote device indicating the fault. See L.E.D Fault Indication below for blink code explanation. The remote device must have a malfunction detection capability when the UPM board is set to "PULSE".



If 24 VAC output is needed R must be wired to ALR-COM terminal; 24 VAC will be available o the ALR-OUT terminal when the unit is in the alarm condition.

- **DISPLAY OUTPUT:** The Display output is a pulse output connected to the Unit Diagnostic Display (UDD) and it pulses 24 VAC when the unit is in an lockout alarm condition.
- **TEST DIP SWITCH:** A test dip switch is provided to reduce all time delays settings to 10 seconds during troubleshooting or verification of unit operation.

NOTICE: Operation of unit in test mode can lead to accelerated wear and premature failure of components. The "TEST" switch must be set back to "NO" after troubleshooting/servicing.

- **FREEZE SENSOR:** The freeze sensor input is active all the time, if a freeze option is not selected the freeze terminals will need a jumper. There are two (2) configurable freeze points, 26°F & 15°F. The unit will enter a soft lock out until the temperature climbs above the set point and the anti-short cycle time delay has expired. The freeze sensor will shut the compressor output down after 30 seconds of water flow loss and report a freeze condition.



It is recommended to have a flow switch to prevent the unit from running if water flow is lost.

NOTICE: If unit is employing a fresh water system (no anti-freeze protection), it is extremely important to have the Freeze1 R30 resistor set to 26°F in order to shut down the unit at the appropriate leaving water temperature and protect your heat pump from freezing.

- **INTELLIGENT RESET:** If a fault condition is initiated, the 5 minute delay on break time period is initiated and the unit will restart after these delays expire. During this period the fault LED will indicate the cause of the fault. If the fault condition still exists or occurs 2 or 4 times (depending on 2 or 4 setting for Lockout dip switch) before 60 minutes, the unit will go into a hard lockout and requires a manual lockout reset. A single condensate overflow fault will cause the unit to go into a hard lockout immediately, and will require a manual lockout reset.
- **LOCKOUT RESET:** A hard lockout can be reset by turning the unit thermostat off and then back on when the “RESET” dip switch is set to “Y” or by shutting off unit power at the circuit breaker when the “RESET” dip switch is set to “R”.



The blower motor will remain active during a lockout condition.

NOTICE: Always check incoming line voltage power supply and secondary control voltage for adequacy.

CUC SOLID STATE

Console Unit Controller

Designed to enhance the unit operation with more flexibility, accurate control and operating modes the CUC provides an increased level of comfort in the conditioned space together with solid state reliability and ease of operation.

The safety functions of the proven UPM module are incorporated into the CUC for unit protection. In addition the following features are present.

- Tactile touch pad for temperature, fan and mode adjustment.
- Digital display of temperature in either degrees Fahrenheit or Celsius.
- LED Display provides indication for unit operating mode as well as fan speed and fault indication for high or low pressure lockout.
- Adjustable Temperature Set point from 60° F through 80° F (15.5° C through 26.7° C).
- Adjustable Temperature Differential between 1° F and 6° F (0.6° C and 3.3° C).
- Selectable options
 - Manual/Automatic changeover
 - Fan speed – High or Low
 - Fan operation constant fan or cycling with compressor
- Additional features
 - 5 minute anti short cycling delay
 - Random start
 - 90 second low pressure bypass timer prevents nuisance lockouts during cold winter start up
 - Intelligent reset allows the unit to automatically restart after 5 minutes if a fault is no longer active.

NOTICE: 40° F clamp-on freeze stat located on the water out piping, where loop temperature is expected to go below water freezing temperature, this stat should be removed from the safety circuit. Based on the application an appropriate amount of antifreeze must be used to protect the heat pump from freezing. The freeze stat is wired in series with the HP switch and the same fault code will be displayed for either condition Refer to the Unit Wiring Diagram

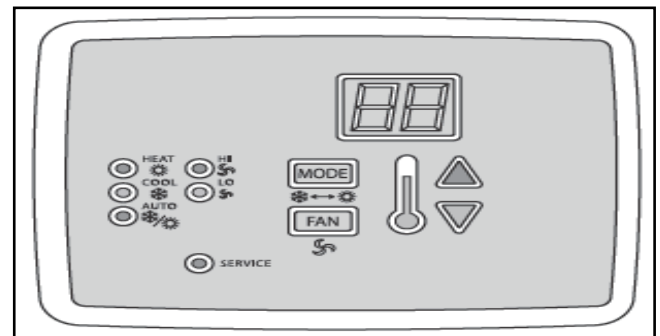

Figure # 4

APPLICATION CONSIDERATIONS

Well Water Systems

NOTICE: In well water applications a slow closing solenoid valve must be used to prevent water hammer.

Copper is adequate for ground water that is not high in mineral content. Should your well driller express concern regarding the quality of the well water available or should any known hazards exist in your area, we recommend proper testing to assure the well water quality is suitable for use with water-source equipment. In conditions anticipating moderate scale formation or in brackish water a cupro-nickel heat exchanger is recommended.

Refer to Water Quality Table on page # 12.

In well water applications water pressure must always be maintained in the heat exchanger. This can be accomplished with either control valve or a bladder type expansion tank. When using a single water well to supply both domestic water and the heat pump, care must be taken to ensure that the well can provide sufficient flow for both.

Solenoid valves should be connected across Y and C on the Terminal block. Make sure that the VA draw of the valve does not exceed the contact rating of the thermostat.

Low Temperature Loop Application

In applications where fluid temperatures may fall below 40 F in a ground water or ground loop applications using a console equipped with a CUC controller the freeze stat will need to be bypassed from the controls circuitry. To accomplish this, follow instructions below:



Figure # 5

Locate High Pressure and Freeze Stat mated wires labeled A&B, respectively. (see figure # 5)



Figure # 6

Disconnect Yellow wire labeled A from black wire labeled B (see figure # 6)



Figure # 7

Locate High Pressure and Freeze Stat mated wires labeled D&C, respectively. (see figure # 7)

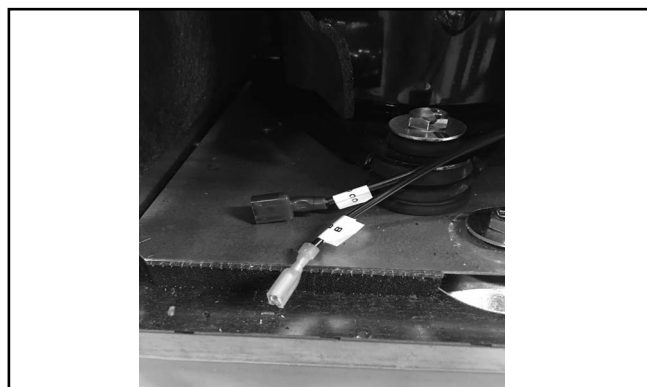

Figure # 8

Disconnect Yellow wire labeled B from Black wire labeled C.(see figure # 8)

**Figure # 9**

Connect Yellow wire labeled A to yellow wire labeled D.(see figure # 9)

**Figure # 10**

Leave Black wires B and C disconnected from any circuits. (see figure # 10)

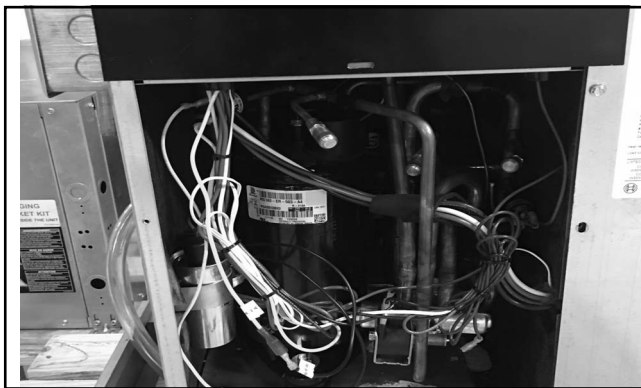
**Figure # 11**

This completes the Freeze Stat Bypass Field Rework. (see figure # 11)

WATER QUALITY

NOTICE: Failure to ensure proper water quality and flow rates can shorten the life of the heat pump and potentially void the unit warranty. (See table # 1)

Maintaining proper water quality is important for ensuring a long and trouble free service life for an BC series heat pump.

For closed loop and boiler/tower systems water chemistry can be checked and easily maintained to ensure that corrosive elements, dissolved oxygen and pH levels are kept in check. It is important to ensure that any additive, antifreeze or corrosion inhibitor that is added to the water loop is compliant with all applicable laws and regulations and is compatible with copper, brass and bronze alloys. ensure that all recommended safety precautions are followed when handling or adding chemicals to the water loop.

For open loop systems, water quality is very important. Refer to Quality Table on page# 11 which shows acceptable ranges for a variety of water quality factors. The three main concerns in open loop installations are scaling, corrosion and fouling.

In installations with hard water, scaling due to a buildup of carbonates on the heat exchanger wall can gradually degrade the heat pump performance over time. Heat pumps that are affected by scaling may exhibit low suction pressures in heating and high head pressures in cooling with a gradual loss of capacity and efficiency. Scaled heat exchangers can be cleaned by a qualified technician but care should be taken to avoid scaling in the first place.

To limit scaling, water flow rates should be kept at 3 gallons/minute per nominal cooling ton (a 10°F temperature rise in cooling) and care should be taken to avoid air in the water lines from suction side leaks. Cupro-nickel coils are generally recommended.

In installations with high hydrogen sulfide, chlorine or ammonia, corrosion is a potential problem. In these installations a cupro-nickel heat exchanger is recommended along with maintaining proper flow and keeping air out of the system. If water quality is outside of the values in water quality table, then a closed loop is recommended.

Fouling due to iron bacteria can also pose problems in some open loop installations. Iron bacteria fouling can quickly degrade system performance and plug heat exchangers.

Air in the water system will greatly accelerate the fouling or corrosion process.

WATER QUALITY TABLE

Table 1: Water Quality			
POTENTIAL PROBLEM	Water Characteristic	Acceptable Value	
		Copper	Cupro-Nickel
	pH (Acidity/Alkalinity)	7-9	7-9
SCALING	Hardness (CaCO ₃ , MgCO ₃)	< 350 ppm	< 350 ppm
	Ryznar Stability Index	6.0 - 7.5	6.0 - 7.5
	Langelier Saturation Index	-0.5 - +0.5	-0.5 - +0.5
CORROSION	Hydrogen Sulfide (H ₂ S)	< 0.5 ppm *	10-50 ppm
	Sulfates	< 125 ppm	< 125 ppm
	Chlorine	< 0.5 ppm	< 0.5 ppm
	Chlorides	< 20 ppm	< 150 ppm
	Carbon Dioxide	< 50 ppm	< 50 ppm
	Ammonia	< 2 ppm	< 2 ppm
	Ammonia Chloride	< 0.5 ppm	< 0.5 ppm
	Ammonia Nitrate	< 0.5 ppm	< 0.5 ppm
	Ammonia Hydroxide	< 0.5 ppm	< 0.5 ppm
	Ammonia Sulfate	< 0.5 ppm	< 0.5 ppm
	Dissolved Solids	< 1,000 ppm	< 1,500 ppm
IRON FOULING	Iron (Fe ²⁺ Iron Bacteria Potential)	< 0.2 ppm	< 0.2 ppm
	Iron Oxide	< 1 ppm	< 1 ppm
EROSION	Suspended Solids	< 10 ppm, < 600 µm size **	< 10 ppm, < 600 µm size **
	Maximum Water Velocity	6 ft/sec	6 ft/sec
* No "rotten egg" smell present at < 0.5 ppm H ₂ S.			
** Equivalent to 30 mesh strainer			

Table #1

UPM SEQUENCE OF OPERATION

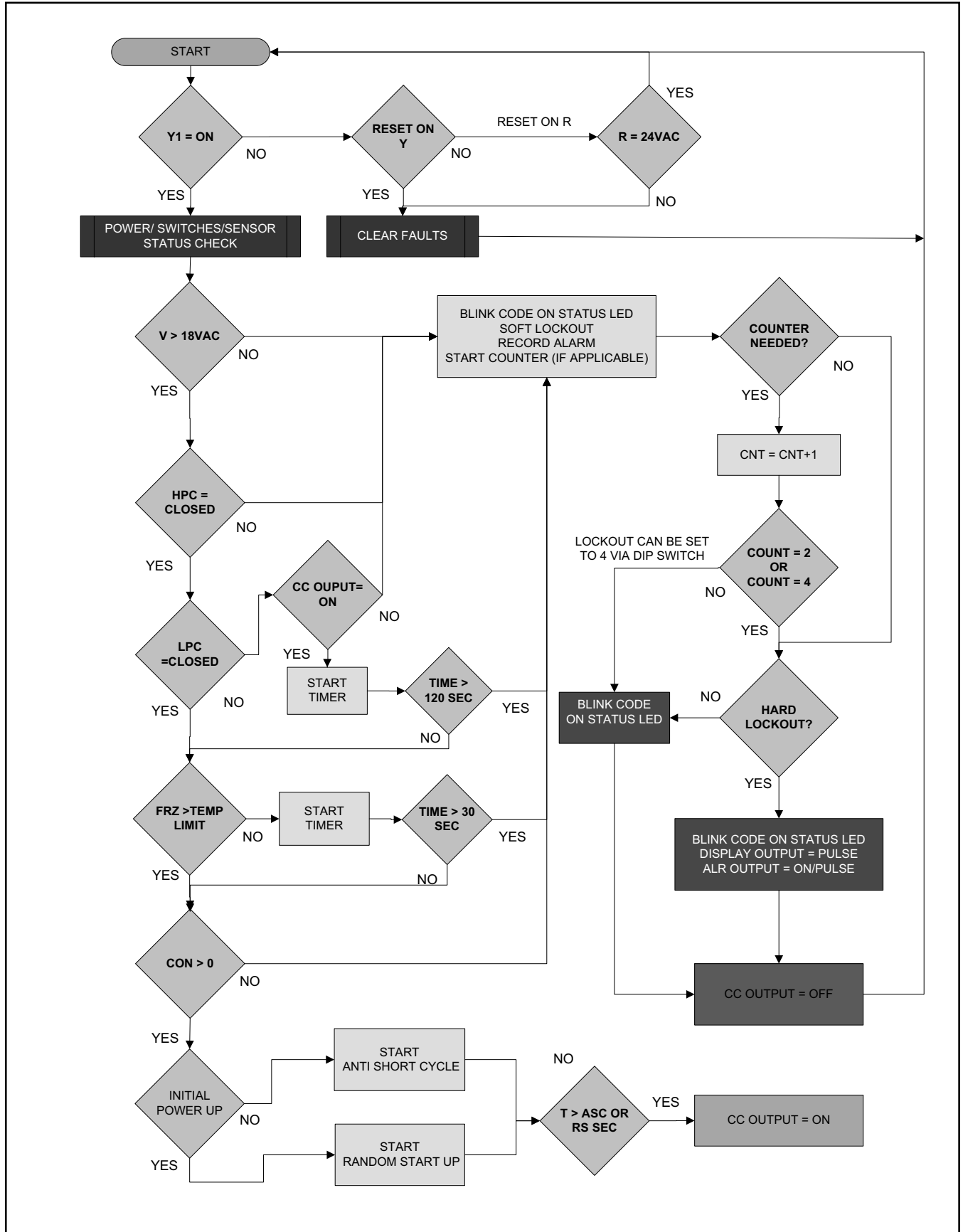

Figure # 12

SEQUENCE OF OPERATION

Cooling Mode

Energizing the “O” terminal energizes the unit reversing valve in the cooling mode. The fan motor starts when the “G” terminal is energized.



A fault condition initiating a lockout will de-energize the compressor irrespective of which stage is engaged.

Heating Mode

The heating (Y) operates in the same manner as cooling, but with the reversing valve de-energized. Once the thermostat is satisfied, the compressor shuts down and the fan ramps down either fan only mode or off.

COOLING TOWER/BOILER SYSTEMS

The cooling tower and boiler water loop temperature is usually maintained between 50° F to 100 ° F to assure adequate cooling and heating performance.

In cooling mode, heat is rejected from the unit into the water loop. A cooling tower provides evaporative cooling to the loop water thus maintaining a constant supply temperature to the unit.

When utilizing open cooling towers, chemical water treatment is mandatory to ensure the water is free from corrosive elements. A secondary heat exchanger (plate frame) between the unit and the open cooling tower may also be used. It is imperative that all air be eliminated from the closed loop side of the heat exchanger to ensure against fouling.

In heating mode, heat is absorbed from the water loop. A boiler can be utilized to maintain the loop at the desired temperature.

NOTICE: Water piping exposed to extreme low ambient temperatures is subject to freezing.

Consult the specification sheets for piping sizes. Teflon tape sealer should be used when connecting to the unit to ensure against leaks and possible heat exchanger fouling. Do not overtighten the connections. Flexible hoses should be used between the unit and the rigid system to avoid possible vibration. Ball valves should be installed in the supply and return lines for unit isolation and unit water flow balancing. Pressure/temperature ports are recommended in both supply and return lines for system flow balancing. Water flow can be accurately set by measuring the water-to-refrigerant heat exchangers water side pressure drop. See specification sheets for water flow vs. pressure drop information.

NOTICE: No unit should be connected to the supply or return piping until the water system has been completely cleaned and flushed to remove any dirt, piping chips or other foreign material.

Supply and return hoses should be connected together during this process to ensure the entire system is properly flushed. After the cleaning and flushing has taken place the unit may be connected to the water loop and should have all valves wide open.

Geothermal (Earth-Coupled) Systems

Closed loop and pond applications require specialized design knowledge. No attempt at these installations should be made unless the dealer has received specialized training. Utilizing the Ground Loop Pumping Package (GLP), makes the installation easy. Anti-freeze solutions are utilized when low evaporating conditions are expected to occur. Refer to the GLP installation manuals for more specific instructions.

SYSTEM CHECKOUT

After completing the installation, and before energizing the unit, the following system checks should be made:

- Verify that the supply voltage to the heat pump is in accordance with the nameplate ratings.
- Make sure that all electrical connections are tight and secure.
- Check the electrical fusing and wiring for the correct size.



WARNING: Ensure cabinet and Electrical Box are properly grounded.

- Verify that the low voltage wiring between the thermostat and the unit is correct.
- Verify that the water piping is complete and correct.
- Check that the water flow is correct, and adjust if necessary.
- Check the blower for free rotation, and that it is secured to the shaft.
- Verify that vibration isolation has been provided.
- Unit is serviceable. Be certain that all access panels are secured in place.

Considerations:



WARNING: Always check incoming line voltage power supply and secondary control voltage for adequacy

1. Transformer primaries are dual tapped for 208 and 230 volts. Connect the appropriate tap to ensure a minimum of 18 volts secondary control voltage. 24 volts is ideal for best operation.

2. Long length thermostat and control wiring leads may create voltage drop. Increase wire gauge or up-size transformers may be required to ensure minimum secondary voltage supply.
3. FHP recommends the following guidelines for wiring between a thermostat and the unit: 18 GA up to 60 foot, 16 GA up to 100 ft and 14 GA up to 140 ft.
4. Do not apply additional controlled devices to the control circuit power supply without consulting the factory. Doing so may void equipment warranties.
5. Check with all code authorities on requirements involving condensate disposal/over flow protection criteria.

UNIT START-UP

1. Set the thermostat to the highest setting.
2. Set the thermostat system switch to “COOL”, and the fan switch to the “AUTO” position. The reversing valve solenoid should energize. The compressor and fan should not run.
3. Reduce the thermostat setting approximately 5 degrees below the room temperature.
4. Verify the heat pump is operating in the cooling mode.
5. Turn the thermostat system switch to the “OFF” position. The unit should stop running and the reversing valve should de energize.
6. Leave the unit off for approximately (5) minutes to allow for system equalization.
7. Turn the thermostat to the lowest setting.
8. Set the thermostat switch to “HEAT”.
9. Increase the thermostat setting approximately 5 degrees above the room temperature.
10. Verify the heat pump is operating in the heating mode.
11. Set the thermostat to maintain the desired space temperature.
12. Check for vibrations, leaks, etc.

TROUBLESHOOTING



Troubleshooting Information Solution column may reflect a possible fault that may be one of, or a combination of causes and solutions. Check each cause and adopt “process of elimination” and or verification of each before making any conclusion.

CUC FAULT CODES

Blinks	Description
1	High Pressure Lockout, Freeze
2	Low Pressure Lockout

UPM Board LED Indications

Indication Color	Blinks	Description
GREEN	Solid	18-30 VAC Power is present
RED	1	High pressure lockout
RED	2	Low pressure lockout
RED	3	Freeze sensor lockout
RED	4	Condensate overflow
RED	5	Brownout
RED	6	Evaporator Freeze condition

Unit Troubleshooting		
Problem	Possible Cause	Checks and Correction
ENTIRE UNIT DOES NOT RUN	Power Supply Off	Apply power, close disconnect.
	Blown Fuse	Replace fuse or reset circuit breaker. Check for correct fuses
	Voltage Supply Low	If voltage is below minimum voltage specified on unit data plate, contact local power company.
	Thermostat	Set the fan to "ON", the fan should run. Set thermostat to "COOL" and lowest temperature setting, the unit should run in the cooling mode (reversing valve energized). Set unit to "HEAT" and the highest temperature setting, the unit should run in the heating mode. If neither the blower or compressor run in all three cases, the thermostat could be miswired or faulty. To ensure miswired or faulty thermostat verify 24 volts is available on the condensing section low voltage terminal strip between "R" and "C", "Y" and "C", and "O" and "C". If the blower does not operate, verify 24 volts between terminals "G" and "C" in the air handler. Replace the thermostat if defective.
BLOWER OPERATES BUT COMPRESSOR DOES NOT	Thermostat	Check setting, calibration, and wiring.
	Wiring	Check for loose or broken wires at compressor, capacitor, or contactor.
	Safety Controls	Check UPM board red default L.E.D. for Blink Code.
	Compressor overload open	If the compressor is cool and the overload will not reset, replace compressor.
	Compressor motor grounded	Internal winding grounded to the compressor shell. Replace compressor. If compressor burnout, install suction filter dryer.
	Compressor windings Open	After compressor has cooled, check continuity of the compressor windings. If the windings are open, replace the compressor.
UNIT OFF ON HIGH PRESSURE CONTROL	Discharge pressure too high	In "COOLING" mode: Lack of or inadequate water flow. Entering water temperature is too warm. Scaled or plugged condenser. In "HEATING" mode: Lack of or inadequate air flow. Blower inoperative, clogged filter or restrictions in duct work.
	Refrigerant charge	The unit is overcharged with refrigerant. Reclaim refrigerant, evacuate and recharge with factory recommended charge.
	High pressure switch	Check for defective or improperly calibrated high pressure switch.
UNIT OFF ON LOW PRESSURE CONTROL	Suction pressure too low	In "COOLING" mode: Lack of or inadequate air flow. Entering air temperature is too cold. Blower inoperative, clogged filter or restrictions in duct work. In "HEATING" mode: Lack of or inadequate water flow. Entering water temperature is too cold. Scaled or plugged condenser.
	Refrigerant charge	The unit is low on refrigerant. Check for refrigerant leaks, repair, evacuate and recharge with factory recommended charge.
	Low pressure switch	Check for defective or improperly calibrated low pressure switch.

Unit Troubleshooting		
Problem	Possible Cause	Checks and Correction
UNIT SHORT CYCLES	Unit oversized	Recalculate heating and or cooling loads.
	Thermostat	Thermostat installed near a supply air grill; relocate thermostat. Readjust heat anticipator.
	Wiring and controls	Check for defective or improperly calibrated low pressure switch.
INSUFFICIENT COOLING OR HEATING	Unit undersized	Recalculate heating and or cooling loads. If excessive, possibly adding insulation and shading will rectify the problem
	Loss of conditioned air by leakage	Check for leaks in duct work or introduction of ambient air through doors or windows
	Airflow	Lack of adequate air flow or improper distribution of air. Replace dirty filter.
	Refrigerant charge	Low on refrigerant charge causing inefficient operation.
	Compressor	Check for defective compressor. If discharge is too low and suction pressure is too high, compressor is not pumping properly. Replace compressor.
	Reversing Valve	Defective reversing valve creating bypass of refrigerant from discharge of suction side of compressor. Replace reversing valve.
	Operating pressures	Compare unit operation pressures to the pressure/temperature chart for the unit.
	TXV	Check TXV for possible restriction or defect. Replace if necessary.
	Moisture, non condensable	The refrigerant system may be contaminated with moisture or non condensable. Reclaim refrigerant, replace filter dryer, evacuate the refrigerant system, and recharge with factory recommended charge.

BLOWER PERFORMANCE DATA

MODELS	MOTOR SPEED	FACTORY SETTING	EXTERNAL STATIC PRESSURE (IN OF WATER) @ 0" ESP
009	HIGH		300
	LOW	X	275
012	HIGH		520
	LOW	X	475
015	HIGH		500
	LOW	X	450
018	HIGH		520
	LOW	X	475

PSC Motor

Electrical Data Table - PSC Blower Motor

MODELS	VOLTAGE CODE	RATED VOLTAGE	VOLTAGE MIN/MAX	COMPRESSOR			TOTAL UNIT PSC MOTOR			COMPRESSOR SERVICE		
				QTY	RLA	LRA	FLA	MIN CIRCUIT AMPS	MAX FUSE/HACR	COLD WINDING RESISTANCE (Ω)		RUN CAPACITOR (μF/V)
										SINGLE PHASE: S-C	SINGLE PHASE: R-C	
009	0	115/1/60	104/126	1	7.0	45.6	2.1	10.9	15	3.48	0.71	35/240
	1	208-230/1/60	197/253	1	3.4	22.2	0.9	5.2	15	7.35	2.95	15/370
	2	265-277/1/60	239/291	1	2.9	18.8	0.7	4.3	15	10.74	4.27	10/440
012	0	115/1/60	104/126	1	9.6	58.4	1.3	13.3	25	3.15	0.58	35/370
	1	208-230/1/60	197/253	1	4.6	27.9	0.8	6.6	15	5.90	2.30	20/370
	2	265-277/1/60	239/291	1	3.8	22.2	0.8	5.6	15	8.70	3.47	15/440
015	0	115/1/60	104/126	1	12.7	63.0	1.3	17.2	25	N/A	N/A	40/370
	1	208-230/1/60	197/253	1	5.6	29.0	0.8	7.8	15	5.45	2.31	25/440
	2	265-277/1/60	239/291	1	4.6	20.0	0.8	6.6	15	7.39	3.58	15/440
018	1	208-230/1/60	197/253	1	7.4	33.0	0.8	10.1	15	3.05*	2.41*	35/370
	2	265-277/1/60	239/291	1	6.0	28.0	0.8	8.3	15	2.57*	3.26*	35/440



* These values are reported at 167°F (75°C), not room temperature. All other resistance values must be measured with compressor at room temperature. Resistance value tolerance +/- 7%.

WATER SIDE PRESSURE DROP

	GPM	Pressure Drop (PSIG)	Pressure Drop (ft of H2O)
009	1.3	0.98	2.25
	1.5	1.26	2.91
	2.0	2.11	4.87
	2.5	3.16	7.29
	3.0	4.39	10.13
012	1.5	1.26	2.91
	2.0	2.11	4.87
	2.5	3.16	7.29
	3.0	4.39	10.1
	4.0	7.36	17.0
015	2.5	1.08	2.50
	3.0	1.50	3.47
	3.5	1.98	4.58
	4.0	2.52	5.82
	5.0	3.77	8.70
018	2.5	1.08	2.50
	3.0	1.50	3.47
	4.0	2.52	5.82
	5.0	3.77	8.70
	6.0	5.24	12.1

OPERATING TEMPERATURES & PRESSURES CONSOLES

			OPERATING DATA R-410A								
			COOLING				HEATING				
MODEL	ENTERING FLUID TEMP °F	FLUID FLOW GPM	SUCTION PRESSURE PSIG	DISCHARGE PRESSURE PSIG	FLUID TEMPRISE °F	AIR TEMP DROP °F	SUCTION PRESSURE PSIG	DISCHARGE PRESSURE PSIG	FLUID TEMP DROP °F	AIR TEMP RISE °F	
009	30°	1.5					120-125	295-305	4.3-4.7	12.2-13.4	
		2					125-130	300-310	3.3-3.7	12.4-13.8	
	40°	1.5					120-125	300-305	5.2-5.8	14.3-15.8	
		2					125-130	300-310	4.1-4.5	14.6-16.2	
	50°	1.5	125-130	285-295	12.8-14.2	18.1-20.0	135-140	305-310	6.2-6.8	16.2-18.0	
		2	126-131	275-285	10.5-11.6	18.1-20.0	130-135	310-320	4.8-5.3	16.7-18.5	
	60°	1.5	127-132	295-305	12.6-14.0	17.4-19.2	135-140	315-320	7.1-7.9	18.3-20.3	
		2	125-130	285-295	9.8-10.8	17.6-19.4	140-145	320-330	5.5-6.1	18.8-20.8	
	70°	1.5	132-137	315-325	12.4-13.8	16.7-18.5	155-165	325-335	8.2-9.0	20.0-22.2	
		2	130-135	305-315	9.7-10.7	17.0-18.8	160-170	330-340	6.3-6.9	20.9-23.1	
	80°	1.5	136-141	345-355	12.4-13.7	16.2-17.9	165-175	335-345	9.0-10.0	22.3-24.7	
		2	135-140	335-345	9.5-10.5	16.3-18.1	170-175	340-350	7.0-7.8	22.9-25.3	
	90°	1.5	139-144	370-380	12.2-13.4	15.5-17.1					
		2	137-142	360-370	9.4-10.4	15.7-17.3					
	100°	1.5	141-145	415-425	12.1-13.3	14.8-16.4					
		2	139-144	410-420	9.3-10.3	15.1-16.7					
	012	30°	2					110-115	305-315	4.6-5.0	15.3-16.9
			3					115-120	305-315	3.8-4.2	15.6-17.2
40°		2					110-115	310-315	5.4-6.0	17.4-19.2	
		3					115-120	310-315	4.5-4.9	17.8-19.6	
50°		2	140-145	290-300	12.5-13.9	20.0-22.2	115-120	315-320	6.3-6.9	19.5-21.5	
		3	135-140	270-280	10.3-11.3	20.2-22.4	120-125	320-325	5.1-5.7	19.9-21.9	
60°		2	142-147	320-320	12.4-13.7	19.4-21.4	125-130	325-330	7.0-7.8	21.5-23.7	
		3	137-142	300-310	10.2-11.2	19.7-21.7	130-135	330-335	5.8-6.4	21.9-24.2	
70°		2	145-150	335-345	12.3-13.5	18.9-20.9	145-150	335-240	7.9-8.7	23.5-25.9	
		3	143-152	325-335	10.1-11.1	19.1-21.1	150-155	340-350	7.4-8.2	23.9-26.5	
80°		2	152-157	360-370	12.2-13.4	18.3-20.3	155-160	345-350	8.7-9.7	25.6-28.2	
		3	150-155	350-360	10.0-11.0	18.5-20.5	160-165	350-360	7.1-7.9	26.0-28.8	
90°		2	154-159	385-395	12.1-13.3	17.8-19.6					
		3	152-158	375-385	9.9-10.9	18.1-20.0					
100°		2	156-160	435-445	12.0-13.2	17.3-19.1					
		3	154-159	425-435	9.8-10.8	17.5-19.3					
015		30°	3					110-115	280-290	3.6-4.0	13.6-15.0
			4					110-115	290-295	2.9-3.2	13.9-15.3
	40°	3					115-120	295-300	4.4-4.8	15.8-17.4	
		4					115-120	300-305	3.4-3.8	16.2-17.9	
	50°	3	127-132	275-285	12.4-13.8	21.8-24.0	115-120	305-310	5.2-5.8	18.1-20.1	
		4	125-130	265-275	9.7-10.7	22.0-24.4	120-125	310-315	4.1-4.5	18.5-20.5	
	60°	3	129-135	310-320	12.2-13.4	20.7-22.9	125-130	315-320	6.1-6.7	20.5-22.7	
		4	127-132	295-305	9.4-10.4	21.0-23.2	130-135	320-325	4.8-5.3	21.1-23.3	
	70°	3	135-140	330-340	11.8-13.0	19.8-21.8	145-150	325-330	6.9-7.7	23.0-25.4	
		4	133-138	320-330	9.1-10.1	20.0-22.2	150-155	330-340	5.4-6.0	23.6-26.0	
	80°	3	142-147	355-365	11.5-12.7	18.7-20.7	155-16-	335-340	7.8-8.6	25.3-27.9	
		4	140-145	345-365	8.9-9.9	19.0-21.0	160-165	345-350	6.0-6.6	25.9-28.7	
	90°	3	144-149	380-390	11.1-12.3	17.7-19.5					
		4	143-148	370-380	8.6-9.6	18.0-19.8					
	100°	3	147-152	430-440	10.8-12.0	16.7-18.5					
		4	145-150	420-430	8.4-9.2	16.9-18.7					

WIRING DIAGRAMS

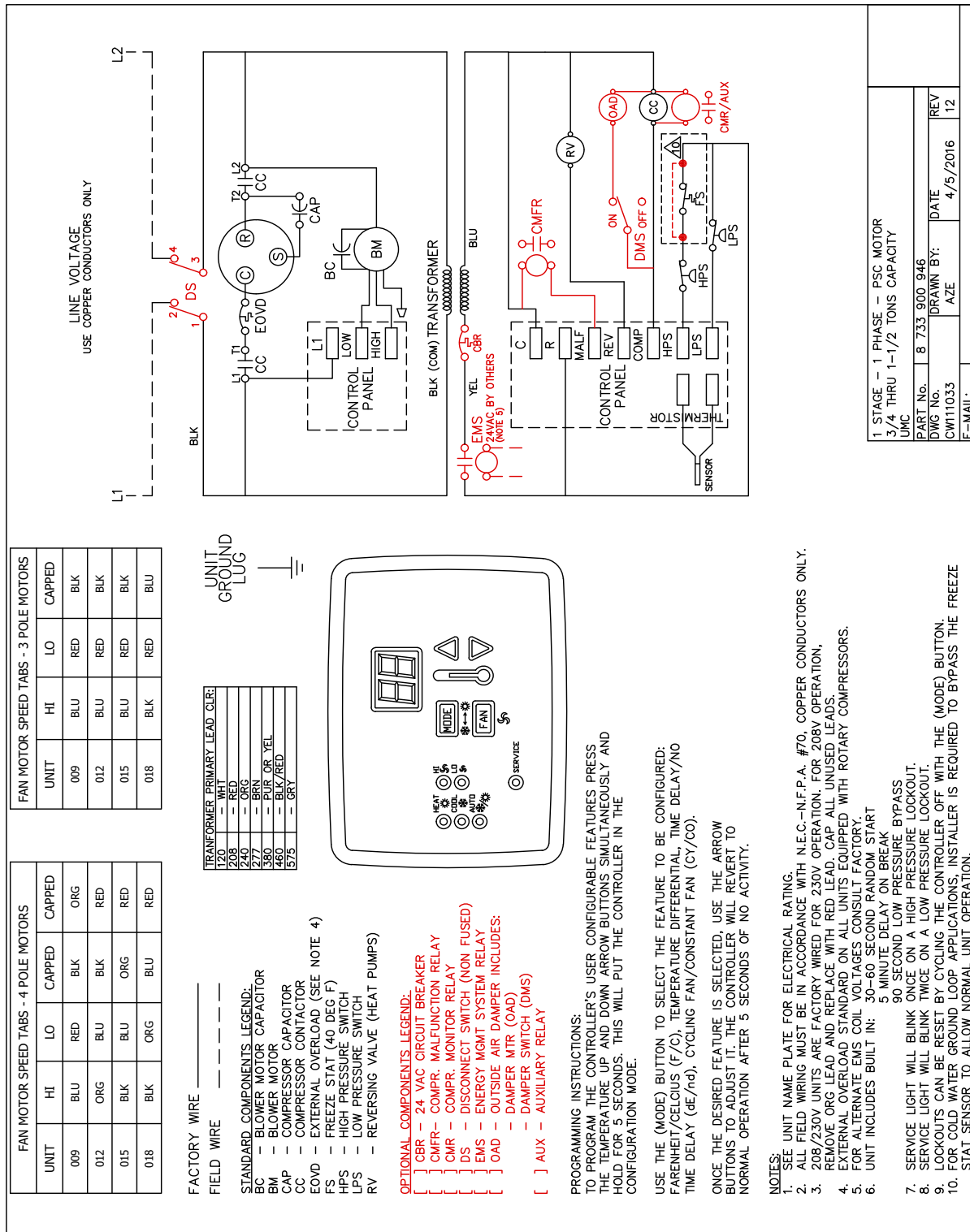

Figure # 13



FOR REFERENCE ONLY Actual unit wiring may vary from this example. Always refer to the wiring diagram attached to the unit.

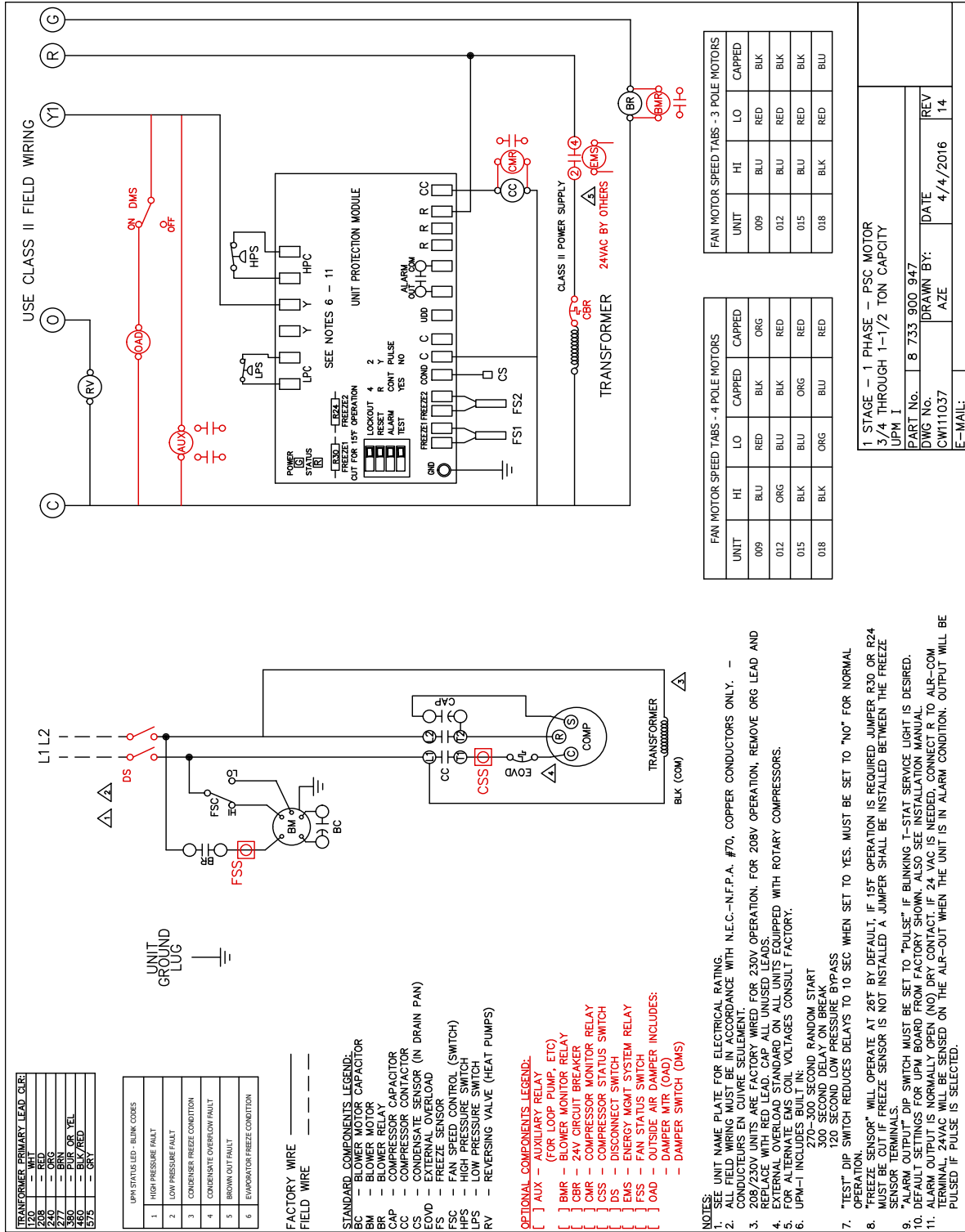

Figure # 14



FOR REFERENCE ONLY Actual unit wiring may vary from this example. Always refer to the wiring diagram attached to the unit.

FAN MOTOR SPEED TABS - 4 POLE MOTORS

UNIT	HI	LO	CAPPED
009	BLU	RED	BLK
012	ORG	BLU	RED
015	BLK	BLU	ORG
018	BLK	ORG	BLU

FAN MOTOR SPEED TABS - 3 POLE MOTORS

UNIT	HI	LO	CAPPED
009	BLU	RED	BLK
012	BLU	RED	BLK
015	BLU	RED	BLK
018	BLK	RED	BLU

1 STAGE - 1 PHASE - PSC MOTOR
3/4 THROUGH 1-1/2 TON CAPACITY
LPM I

PART No.	8 733 900 947
REV	14
DWG No.	
DATE	4/4/2016
DRAWN BY:	AZE
REV	
E-MAIL:	

SCHEMATIC

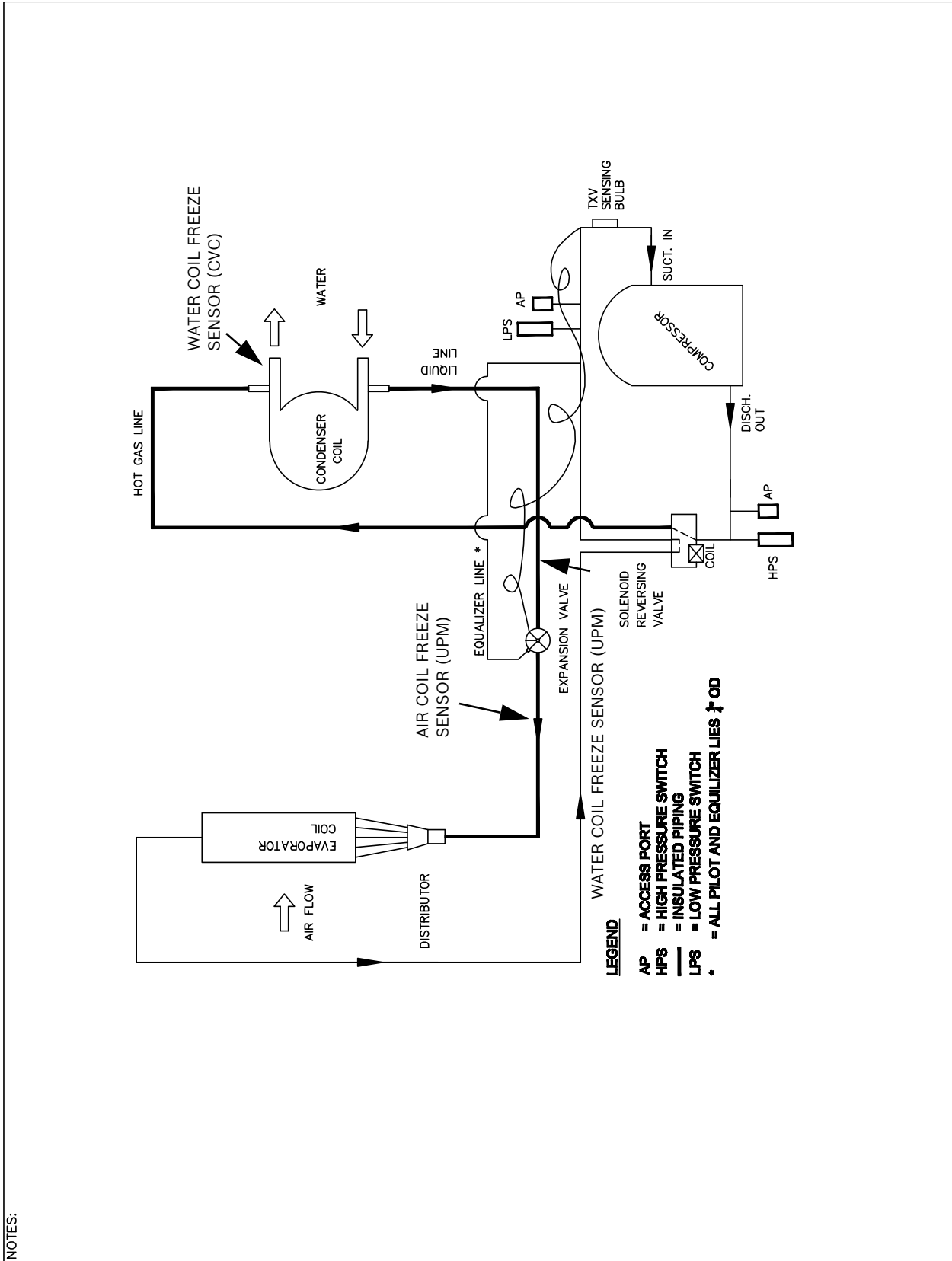

NOTES:

DIMENSIONS STANDARD LENGTH

Model	A	B	C	D	E	F	G	H	J	K	M	N	O	P	Q	R	S	T	U
BC009	48.00	12.00	23.88	6.00	45.00	6.12	3.37	11.00	12.87	30.75	2.87	12.87	12.00	1.63	13.50	5.00	1.75	13.75	1.00
BC012	48.00	12.00	23.88	6.00	45.00	6.12	3.37	11.00	12.87	30.75	2.87	12.87	12.00	1.63	13.50	5.00	1.75	13.75	1.00
BC015	48.00	12.00	23.88	6.00	45.00	6.12	3.37	11.00	12.87	30.75	2.87	12.87	12.00	1.63	13.50	5.00	1.75	13.75	1.00
BC018	48.00	12.00	23.88	6.00	45.00	6.12	3.37	11.00	12.87	30.75	2.87	12.87	12.00	1.63	13.50	5.00	1.75	13.75	1.00

V	W	X	Y	Z	Permanent Washable Filter Size
Water In Depth from Rear	Return Air to Chassis End, Right Hand	Electrical Box Height from Sub-base, Right Hand	Condensate Height from Sub-base, Right Hand	Condensate Depth from Front, Right Hand	Condenser Water Connections
2.00	4.00	15.00	8.69	7.31	5/8" tube 30.12 x 7 x 0.37
2.00	4.00	15.00	8.69	7.31	5/8" tube 30.12 x 7 x 0.37
2.00	4.00	15.00	8.69	7.31	5/8" tube 30.12 x 7 x 0.37
2.00	4.00	15.00	8.69	7.31	5/8" tube 30.12 x 7 x 0.37

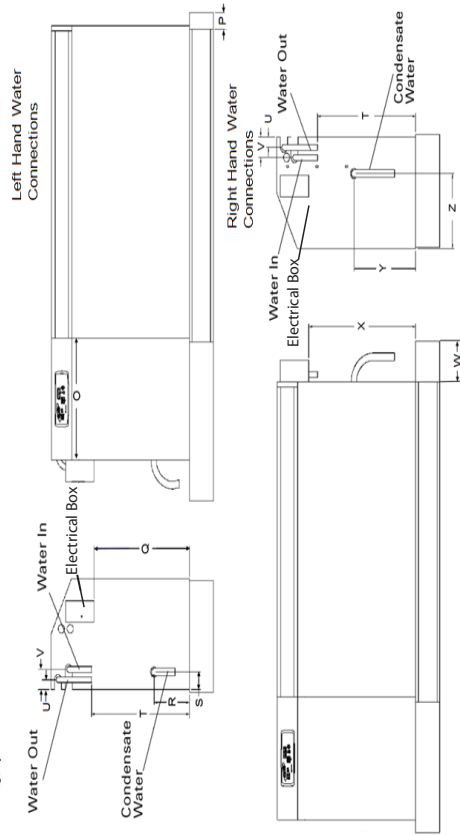
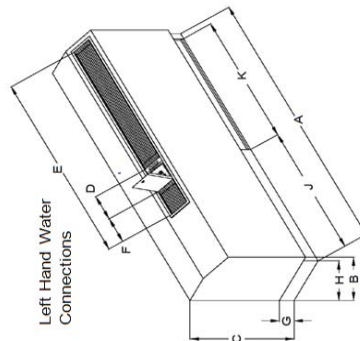
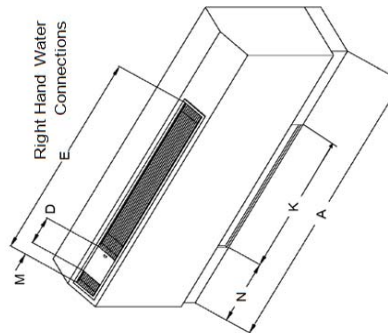

DIMENSIONS EXTENDED LENGTH

Model	A	B	C	D	E	F	G	H	J	K	M	N	O	P	Q	R	S
BC009	63.00	12.00	23.88	6.00	45.00	6.12	3.37	11.00	30.87	30.75	2.87	12.87	12.00	1.63	13.50	5.00	1.75
BC012	63.00	12.00	23.88	6.00	45.00	6.12	3.37	11.00	30.87	30.75	2.87	12.87	12.00	1.63	13.50	5.00	1.75
BC015	63.00	12.00	23.88	6.00	45.00	6.12	3.37	11.00	30.87	30.75	2.87	12.87	12.00	1.63	13.50	5.00	1.75
BC018	63.00	12.00	23.88	6.00	45.00	6.12	3.37	11.00	30.87	30.75	2.87	12.87	12.00	1.63	13.50	5.00	1.75

T	U	V	W	X	Y	Z	Permanent Washable Filter Size
Water Connection Height from Sub-base	Water Out Depth from Rear	Water In Depth from Rear	Return Air to Chassis End, Right Hand	Electrical Box Height from Sub-base, Right Hand	Condensate Height from Sub-base, Right Hand	Condensate Depth from Front, Right Hand	
13.75	1.00	2.00	4.00	15.00	8.69	7.31	30.12 x 7 x 0.37
13.75	1.00	2.00	4.00	15.00	8.69	7.31	30.12 x 7 x 0.37
13.75	1.00	2.00	4.00	15.00	8.69	7.31	30.12 x 7 x 0.37
13.75	1.00	2.00	4.00	15.00	8.69	7.31	30.12 x 7 x 0.37

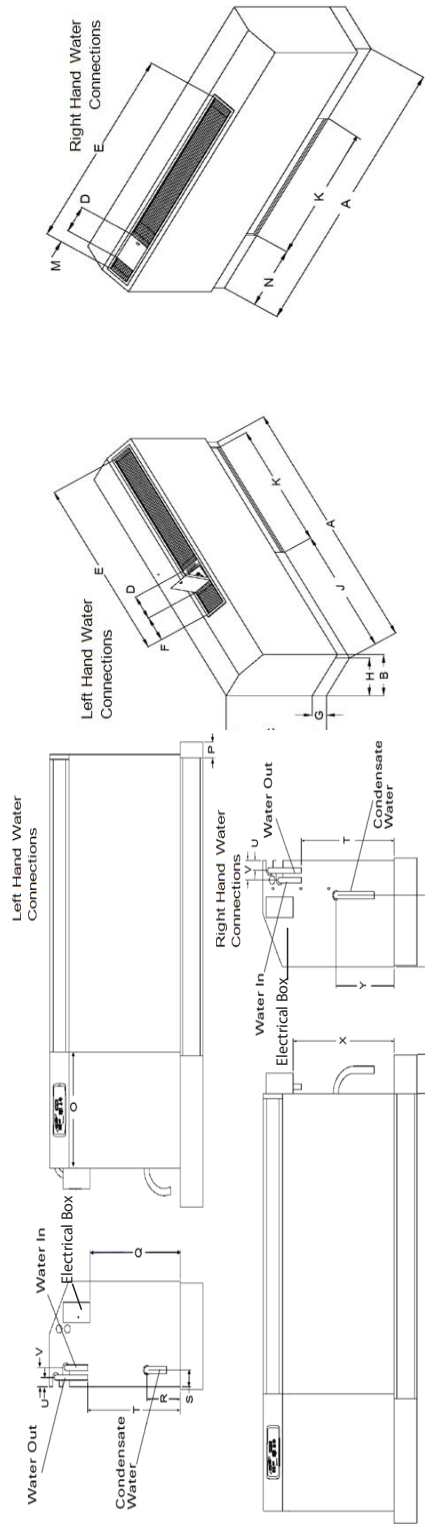

UNIT CHECK-OUT SHEET

Customer Data

Customer Name _____

Date _____

Address _____

Phone _____

Unit Number _____

Unit Nameplate Data

Unit Make _____

Model Number _____

Serial Number _____

Refrigerant Charge (oz) _____

Compressor: RLA _____

LRA _____

Blower Motor: FLA (or NPA) _____

HP _____

Maximum Fuse Size (Amps) _____

Maximum Circuit Ampacity _____

Operating Conditions

Cooling Mode

Heating Mode

Entering / Leaving Air Temp _____ / _____

_____ / _____

_____ / _____

Entering Air Measured at: _____

Leaving Air Measured at: _____

Entering / Leaving Fluid Temp _____ / _____

_____ / _____

_____ / _____

Fluid Flow (gpm) _____

Compressor Volts / Amps _____ / _____

_____ / _____

_____ / _____

Blower Motor Volts / Amps _____ / _____

_____ / _____

_____ / _____

Source Fluid Type _____

Fluid Flow (gpm)* _____

Fluid Side Pressure Drop* _____

Suction / Discharge Pressure (psig)* _____ / _____

_____ / _____

_____ / _____

Suction / Discharge Temp* _____ / _____

_____ / _____

_____ / _____

Suction Superheat* _____

Entering TXV / Cap Tube Temp* _____

Liquid Subcooling* _____

* Required for Troubleshooting ONLY

Auxiliary Heat

Unit Make _____

Model Number: _____

Serial Number _____

Max Fuse Size (Amps) _____

Volts / Amps _____

Entering Air Temperature _____

Leaving Air Temperature _____

Bosch
 555 NW 65th Court
 Fort Lauderdale, FL 33309
 Phone: (954) 776-5471
 Fax: (800) 776-5529

MAINTENANCE

1. Filter changes or cleaning are required at regular intervals. The time period between filter changes will depend upon type of environment the equipment is used in. In a single family home, that is not under construction, changing or cleaning the filter every 60 days is sufficient. In other applications such as motels, where daily vacuuming produces a large amount of lint, filter changes may need to be as frequent as biweekly.

NOTICE: Equipment should never be used during construction due to likelihood of wall board dust accumulation in the air coil of the equipment which permanently affects the performance and may shorten the life of the equipment.

2. An annual “checkup” is required by a licensed refrigeration Technician. Recording the performance measurements of volts, amps, and water temperature differences (both heating and cooling) is recommended. This data should be compared to the information on the unit’s data plate and the data taken at the original startup of the equipment.
3. The condensate drain must be checked annually by cleaning and flushing to ensure proper drainage.
4. Periodic lockouts almost always are caused by air or water flow problems. The lockout (shutdown) of the unit is a normal protective measure in the design of the equipment. If continual lockouts occur call a technician immediately and have them check for: water flow problems, water temperature problems, air flow problems or air temperature problems. Use of the pressure and temperature charts for the unit may be required to properly determine the cause

INFORMATION ON DECOMMISSIONING

Only Trained and qualified technicians are allowed to decommission and dispose of equipment following applicable requirements and local codes.



WARNING: Decommissioning of this equipment can be hazardous due to system pressure and electrical components. Only trained and qualified personnel should install, repair, or service the equipment.

Protecting the Environment

Components

Many parts in the Heat Pump can be fully recycled in the end of the product life. Contact your city authorities for information about the disposal of recyclable products.

Refrigerant

At the end of the service life of this appliance and prior to its environmental disposal, a person qualified to work with refrigerant circuits must recover the refrigerant from within the sealed system as per applicable local codes.



By disposing of this product correctly you will help ensure that the waste undergoes the necessary treatment, recovery and recycling—thus preventing potential negative effects on the environment and human health which could otherwise arise due to inappropriate waste handling.

TERMINOLOGY

PSC - Permanent-split capacitor motor

EER - Energy Efficiency Ratio

COP - Coefficient of Performance. The COP provides a measure of performance for heat pumps that is analogous to thermal efficiency for power cycles.

ECM-Electronically Commutated Motor.

UPM-Unit Protection Module

WLHP - Water Loop Heat Pump

GLHP - Ground Loop Heat Pump

RLA - Running Load Amps

LRA - Locked Rotor Amps

FLA - Full Load Amps

NPA - Name Plate Amps

HP - Heat Pump

SSA - Smart Start Assist

Suction Pressure - Pressure entering compressor

Discharge Pressure - Pressure leaving compressor

(R/A) - Return Air

Recovery - Means the collection and storage of fluorinated greenhouse gases from products, including containers, and equipment during maintenance or servicing or prior to the disposal of the products or equipment.

Recycling- Means the reuse of a recovered fluorinated greenhouse gas following a basic cleaning process.

Reclamation-Means the reprocessing of a recovered fluorinated greenhouse gas in order to match the equivalent performance of a virgin substance, taking into account its intended use.

Decommissioning- Means the final shut-down and removal from operation or usage of a product or piece of equipment containing fluorinated greenhouse gases.

Repair- Means the restoration of damaged or leaking products or equipment that contain, or whose

functioning relies upon, fluorinated greenhouse gases, involving a part containing or designed to contain such gases.

Conditioned space Space within a building provided with heated or cooled air, or both (or surfaces); and, where required, with humidification or dehumidification means, to maintain conditions for an acceptable thermal environment.



BOSCH

Bosch Thermotechnology Corp
555 NW 65th Court
Ft.Lauderdale, FL 33309
Phone: 954-776-5471 | Fax: 954-776-5529
www.bosch-climate-us
Revised: 04/2016

